

place in scan matrix? would need 3-4 wires to UPPER board instead of 2!  
 No. VOL+ or VOL- can either be connected to GPIOs  
 or drive two FETs that sit in the keyboard matrix  
 in any case it is sufficient to connect GPIO-VOL+ and VOL- to two pins on the B2B connector

## Buttons

TITLE: Neo900

Document Number:

REV:  
V2b

Date: 08.10.15 11:01

Sheet: 1/38

can be used to test/operate the modem through the OTG port (w/o UPPER PCB)

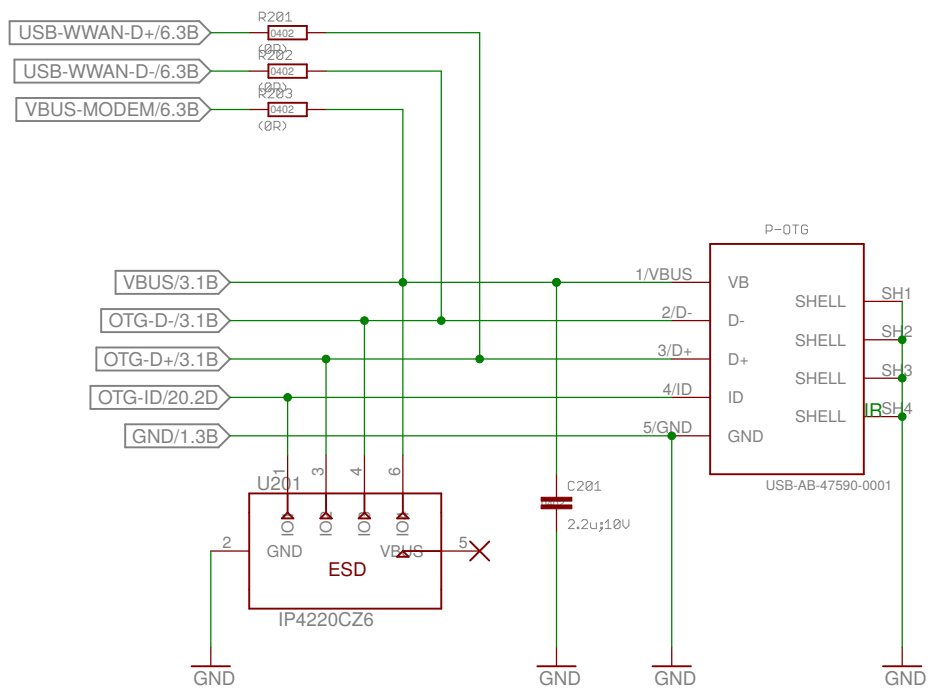

# OTG

TITLE: Neo900

Document Number:

REV:  
V2b

Date: 08.10.15 11:01

Sheet: 2/38

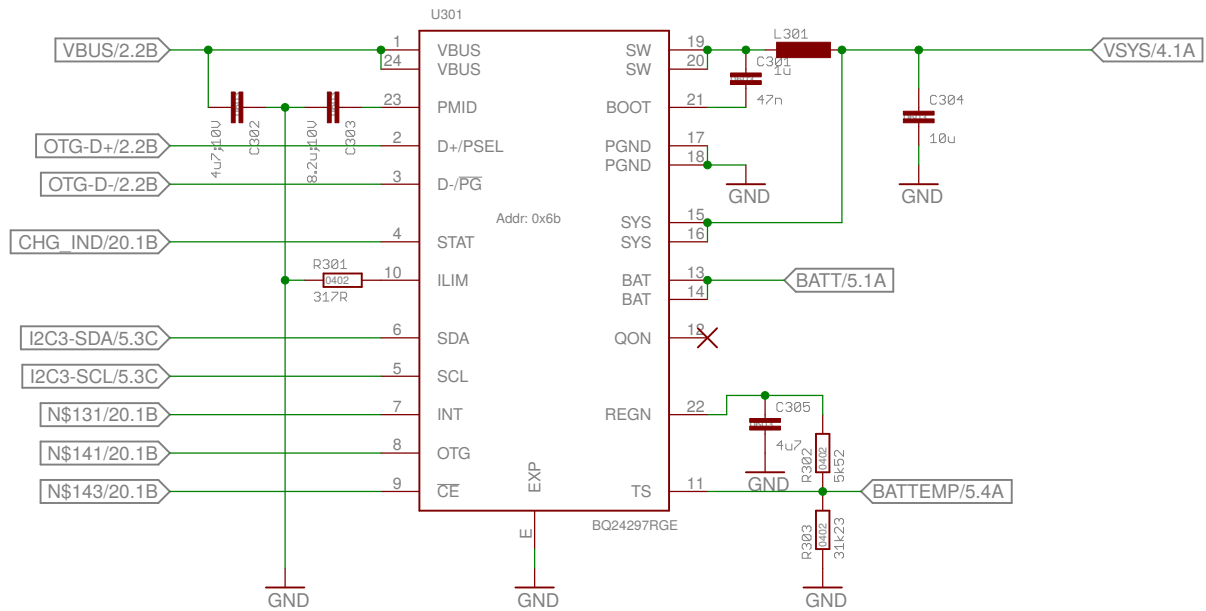

# Charger/OTG-Booster

TITLE: Neo900

Document Number:

REV:  
V2b

Date: 08.10.15 11:01

Sheet: 3/38

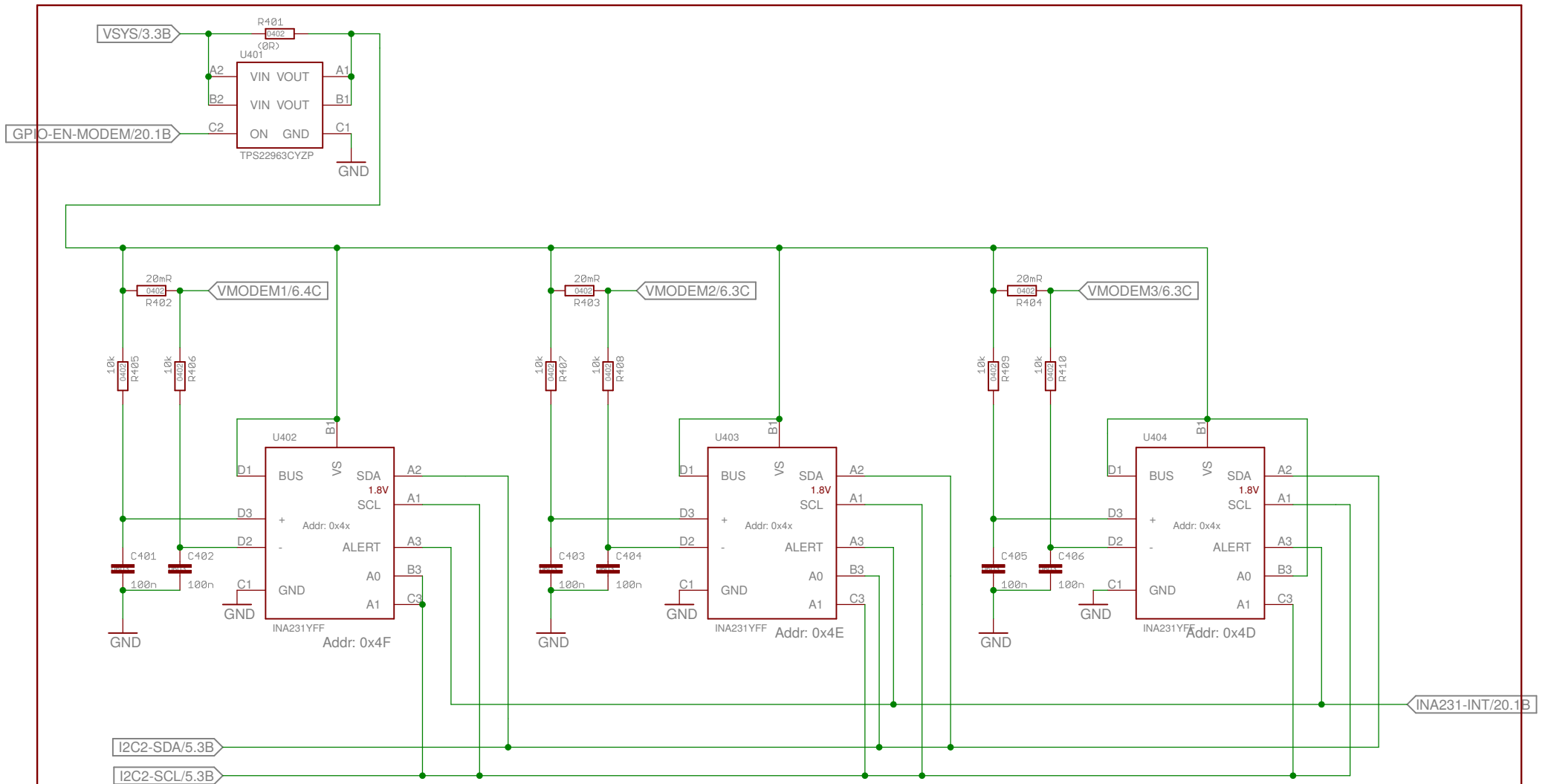

# Modem Power

TITLE: Neo900

Document Number:

REV:  
V2b

Date: 08.10.15 11:01

Sheet: 4/38

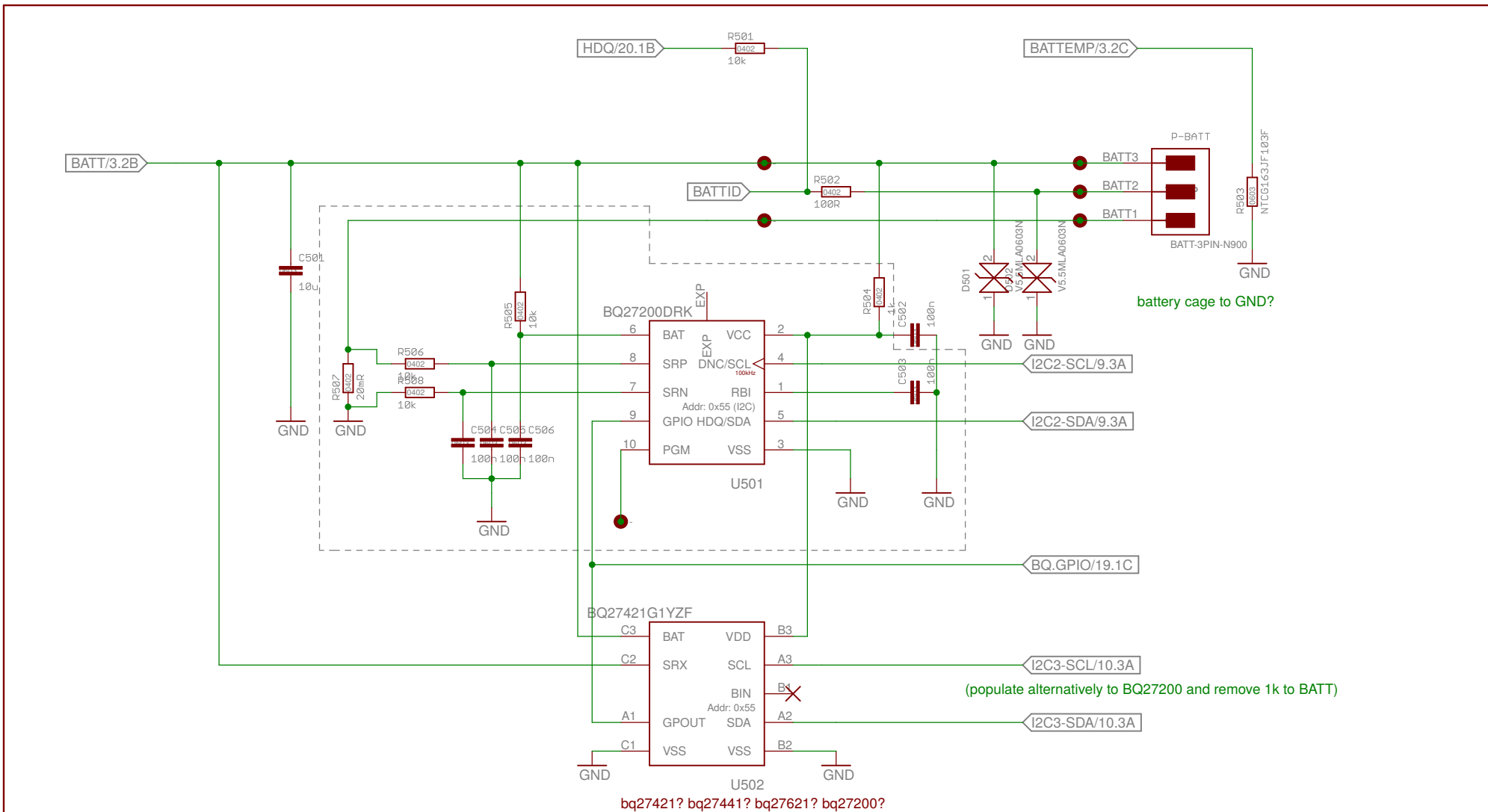

# Fuel Gauge

TITLE: Neo900	
Document Number:	REV: V2b
Date: 08.10.15 11:01	Sheet: 5/38

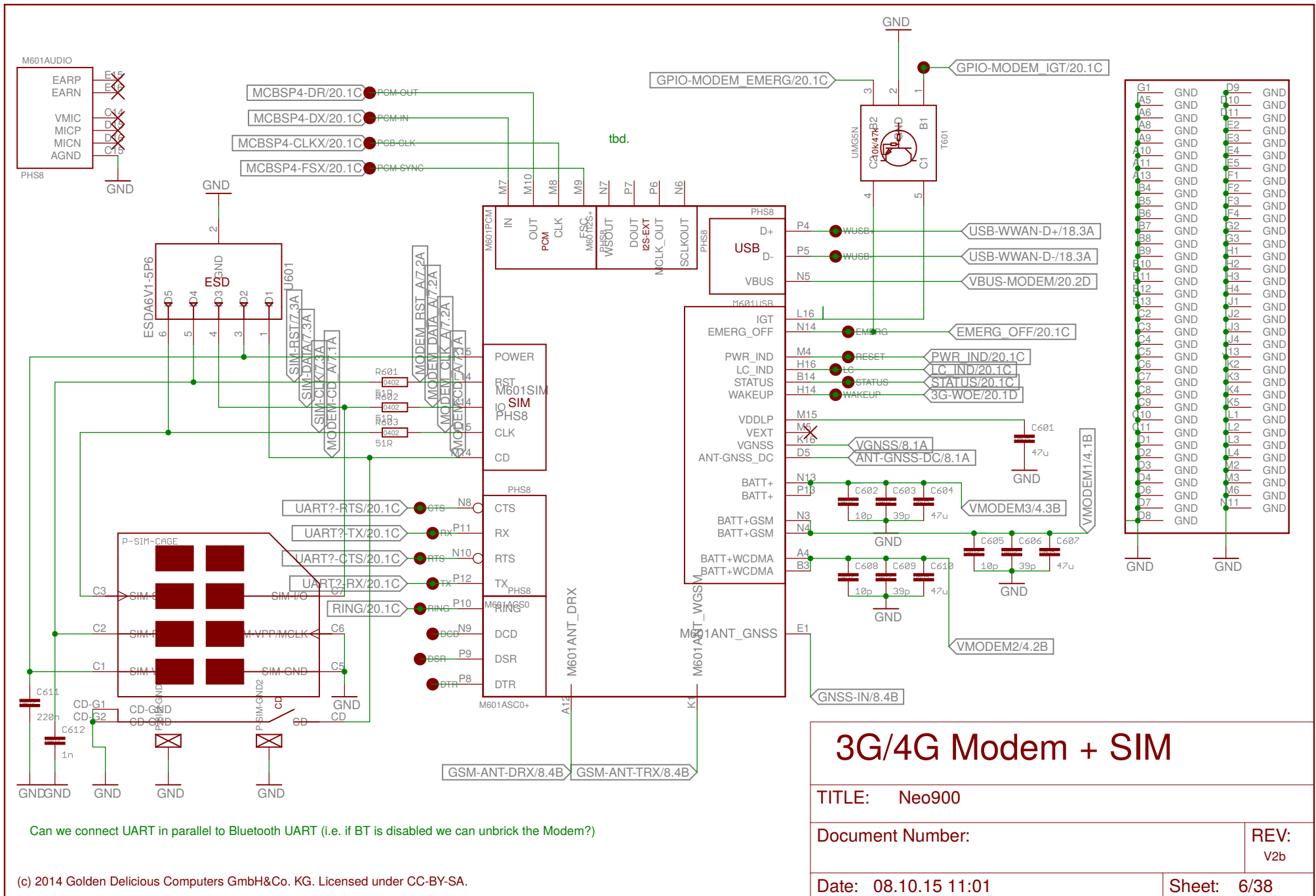

# 3G/4G Modem + SIM

TITLE: Neo900	
Document Number:	REV: V2b
Date: 08.10.15 11:01	Sheet: 6/38

Can we connect UART in parallel to Bluetooth UART (i.e. if BT is disabled we can unbrick the Modem?)

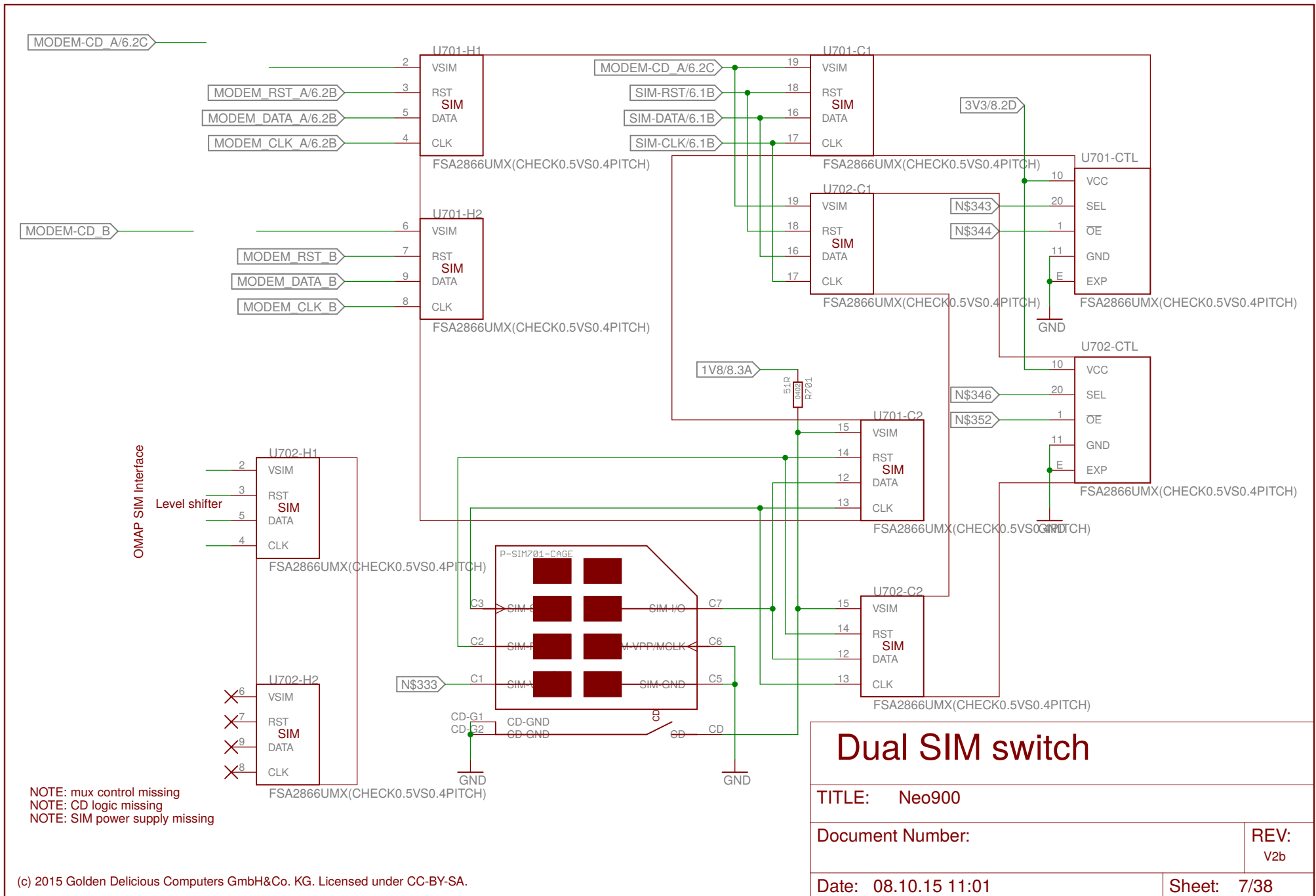

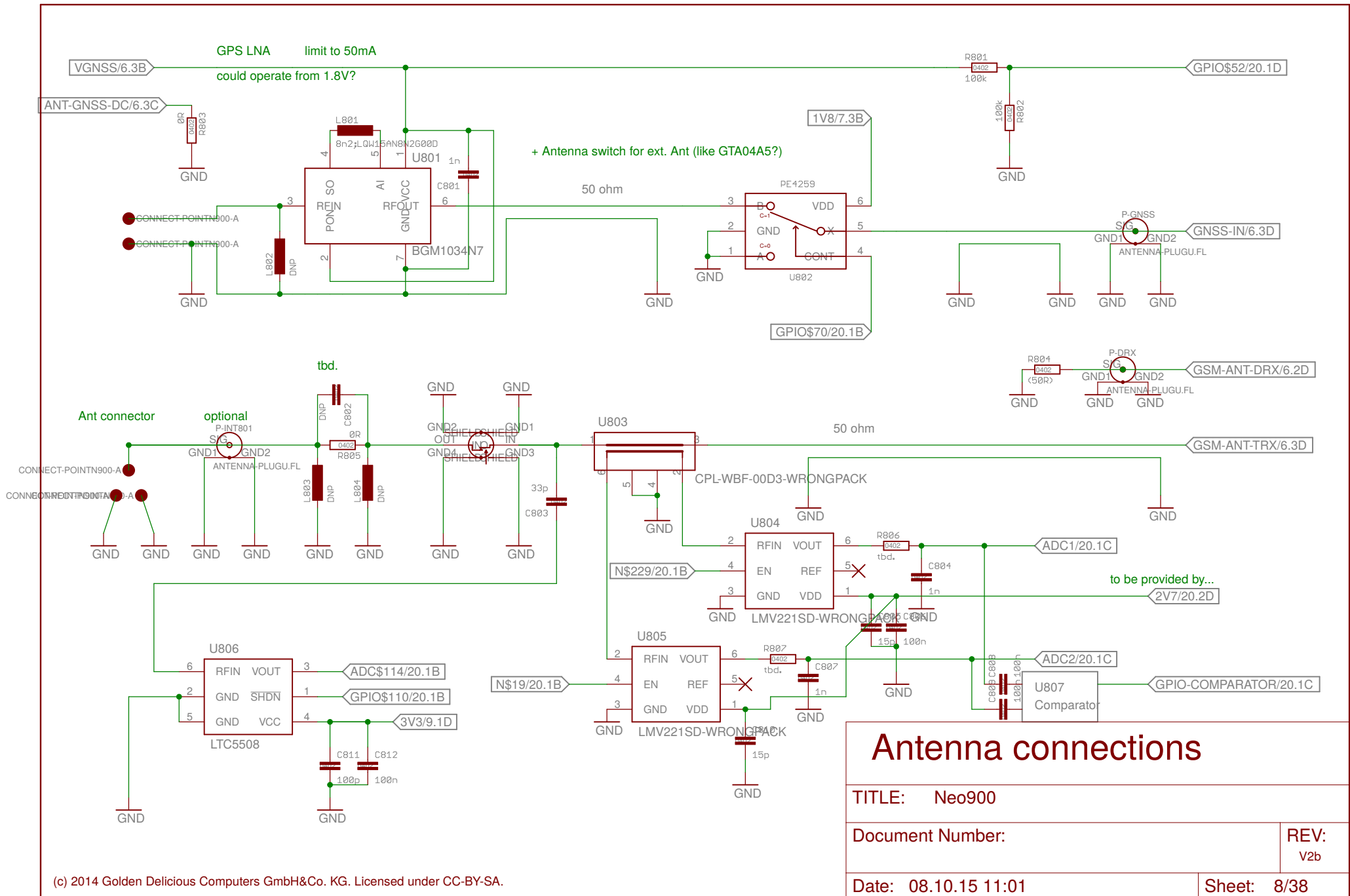

# Antenna connections

TITLE: Neo900

Document Number:

REV:  
V2b

Date: 08.10.15 11:01

Sheet: 8/38



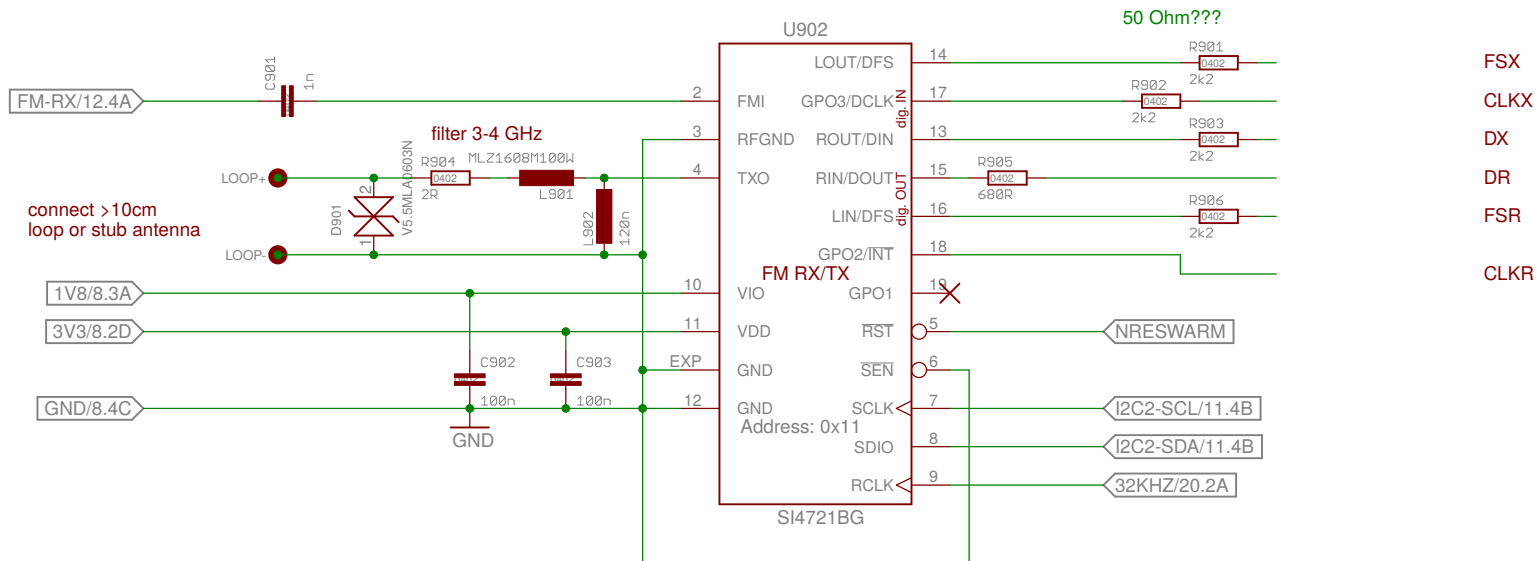
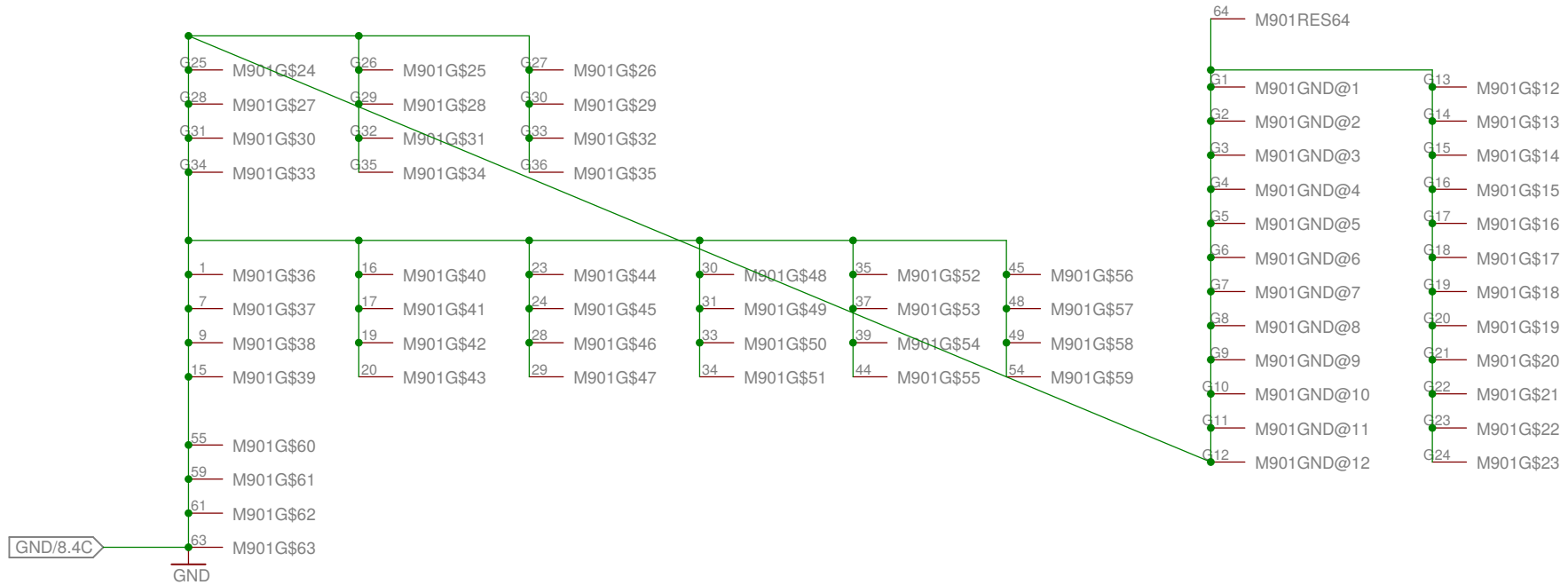

Si4705 is pin compatible (mostly) but RX-only

WiLink5

Dämpfungs-RC's?

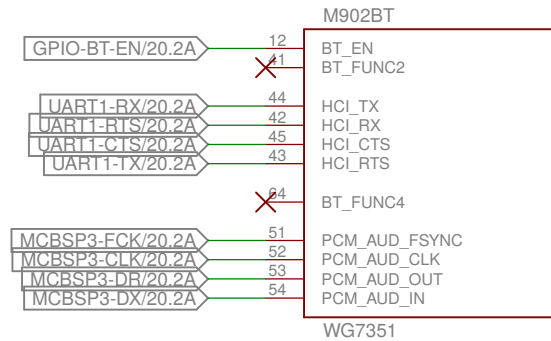
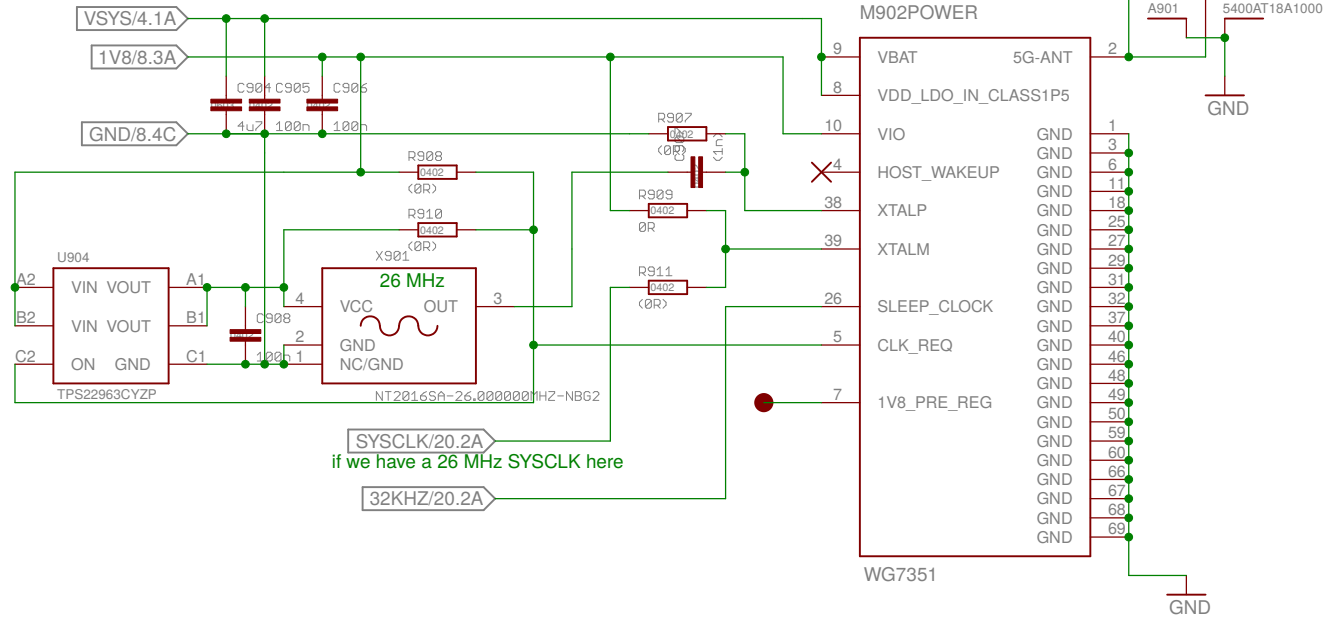
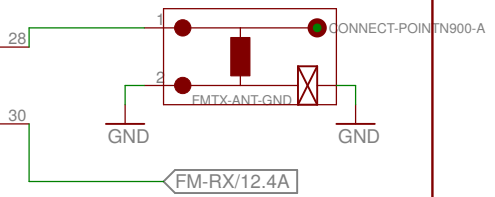
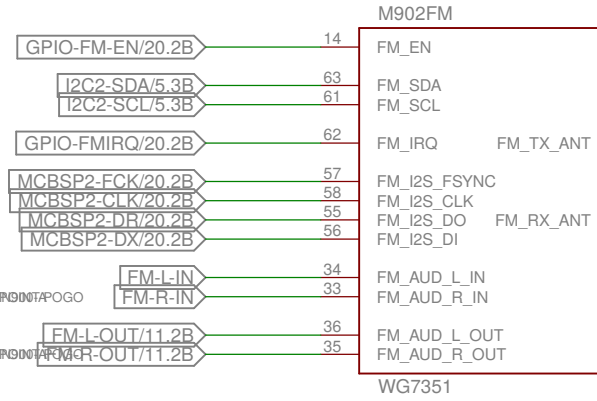
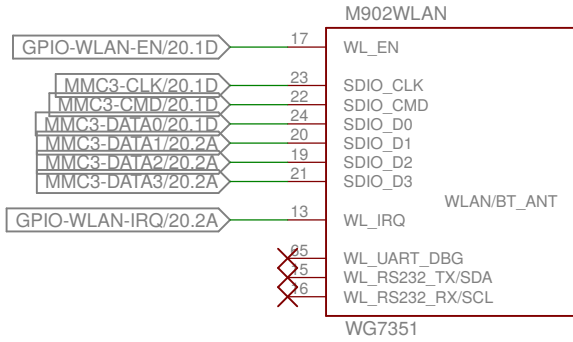

# WLAN & Bluetooth & FM

TITLE: Neo900

Document Number:

REV: V2b

Date: 08.10.15 11:01

Sheet: 9/38

WiLink8

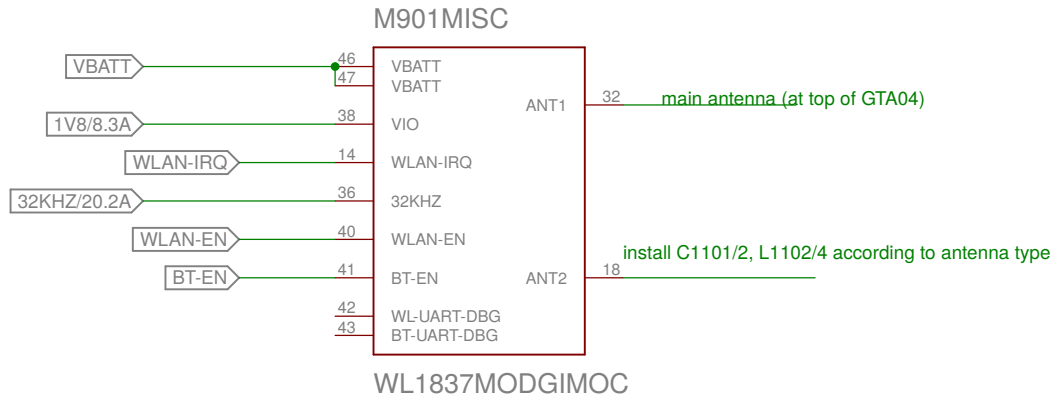
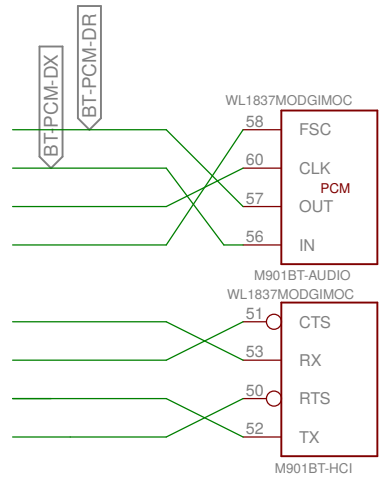

secondary (on the side of GTA04)  
could be 5.8GHz as well

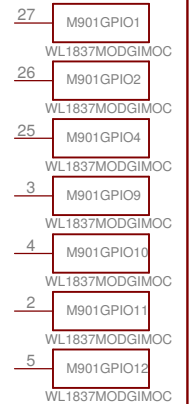
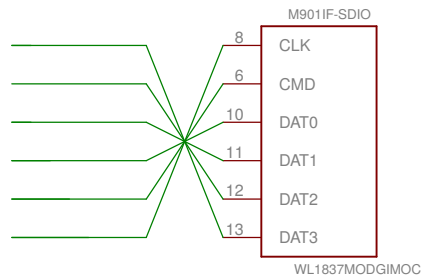

## WLAN & Bluetooth & FM

TITLE: Neo900

Document Number:

REV:  
V2b

Date: 08.10.15 11:01

Sheet: 9/38

WiLink6

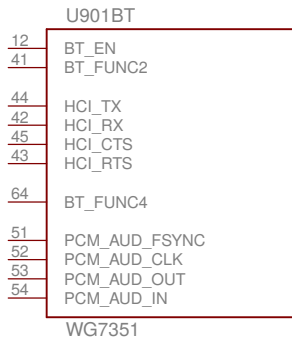
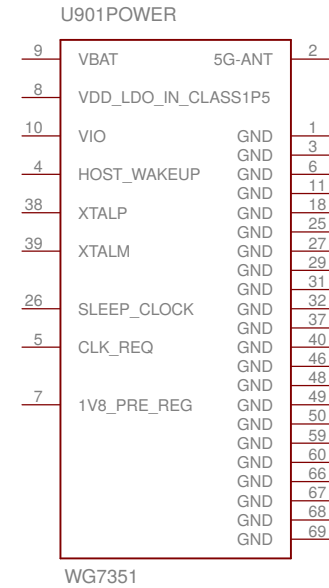
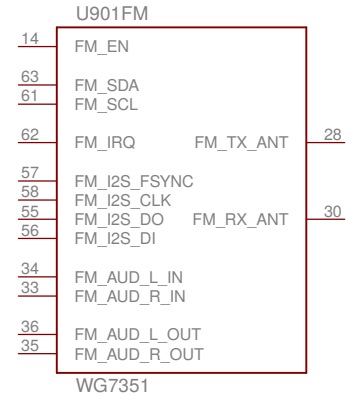
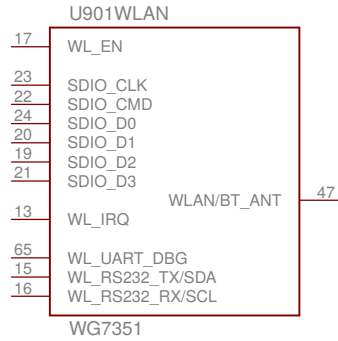

# WLAN & Bluetooth & FM

TITLE: Neo900

Document Number:

REV:  
V2b

Date: 08.10.15 11:01

Sheet: 9/38

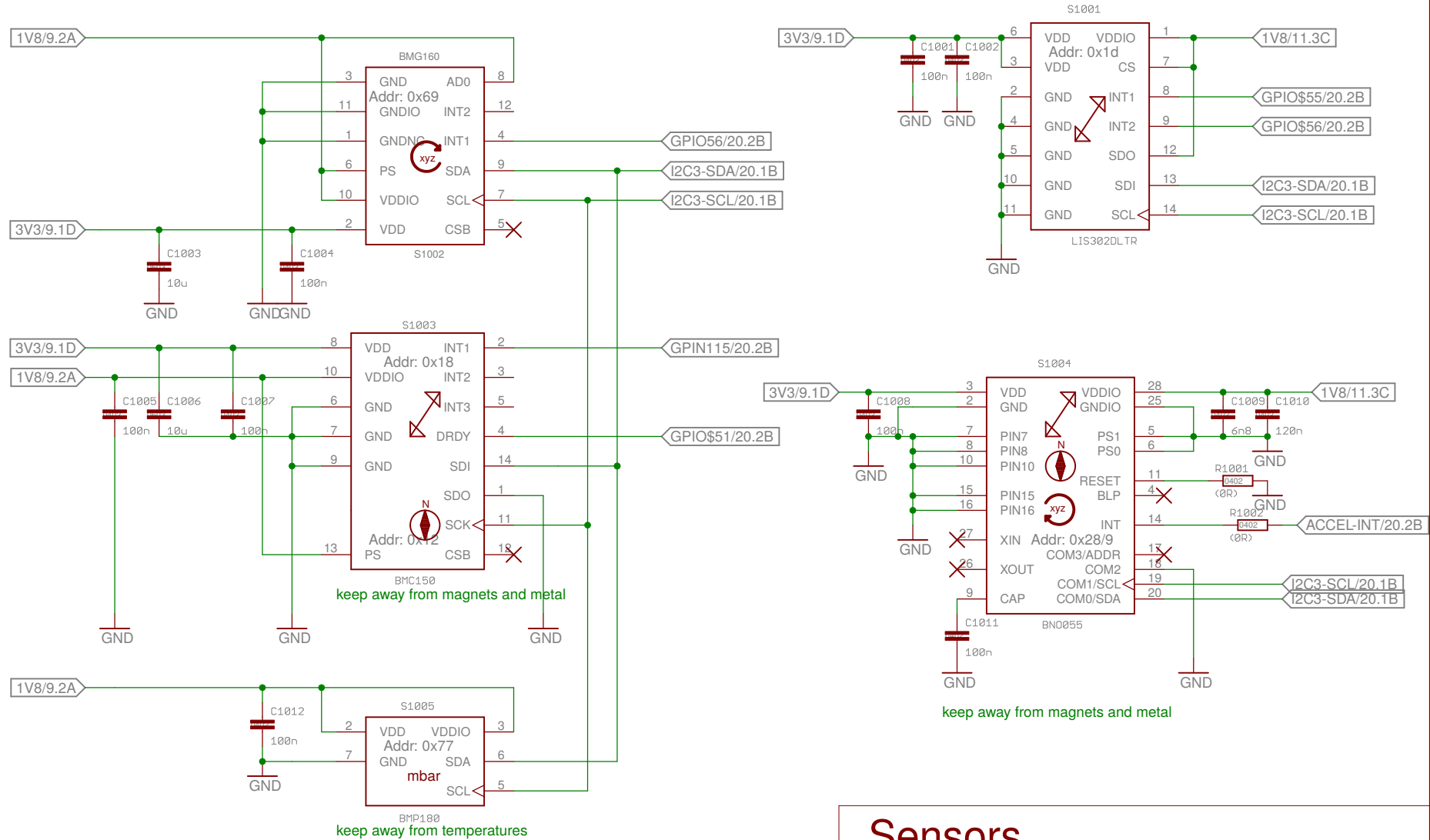

# Sensors

TITLE: Neo900

Document Number:

REV:  
V2b

Date: 08.10.15 11:01

Sheet: 10/38

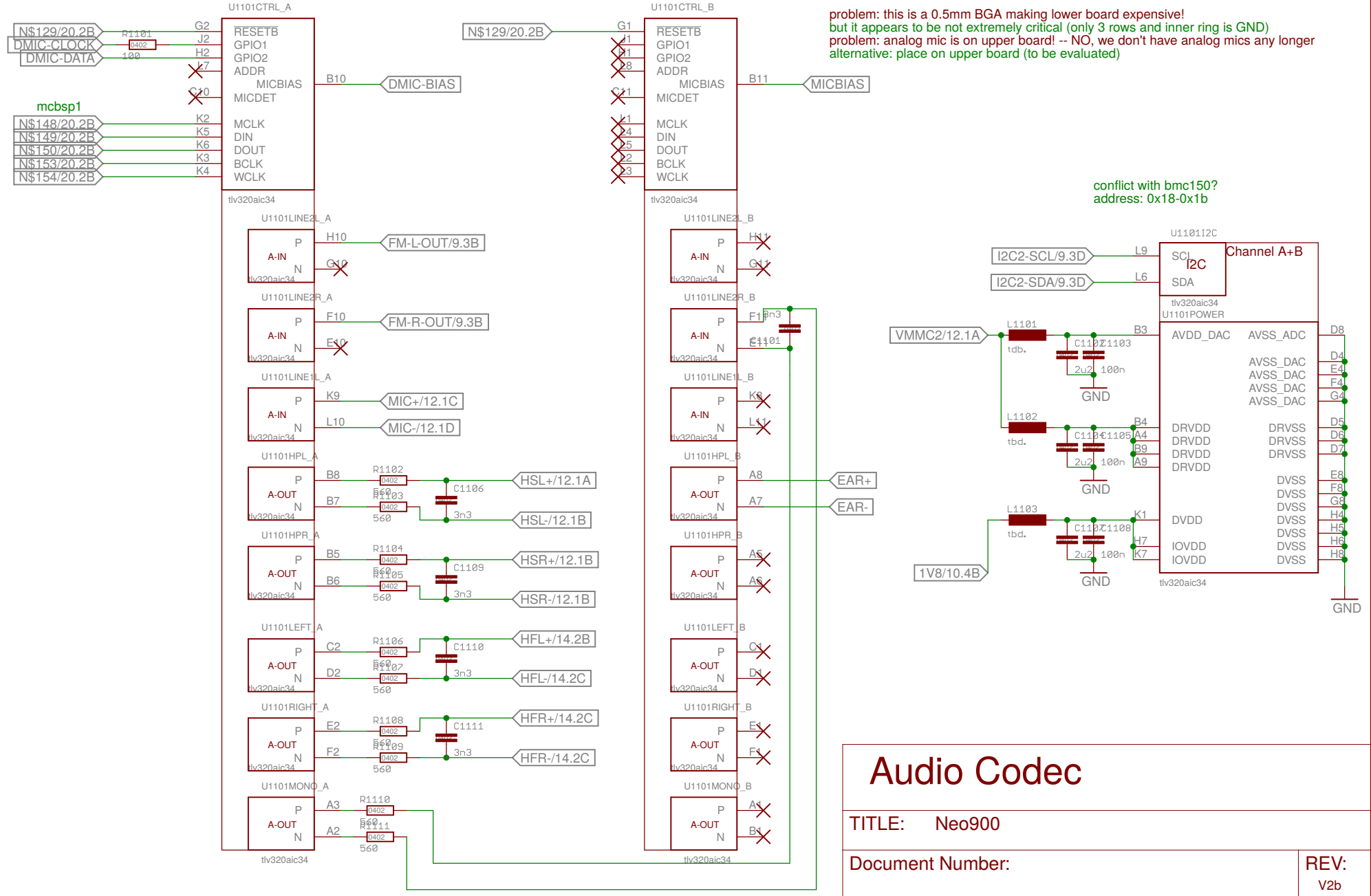

# Audio Codec

TITLE: Neo900	
Document Number:	REV: V2b
Date: 08.10.15 11:01	Sheet: 11/38

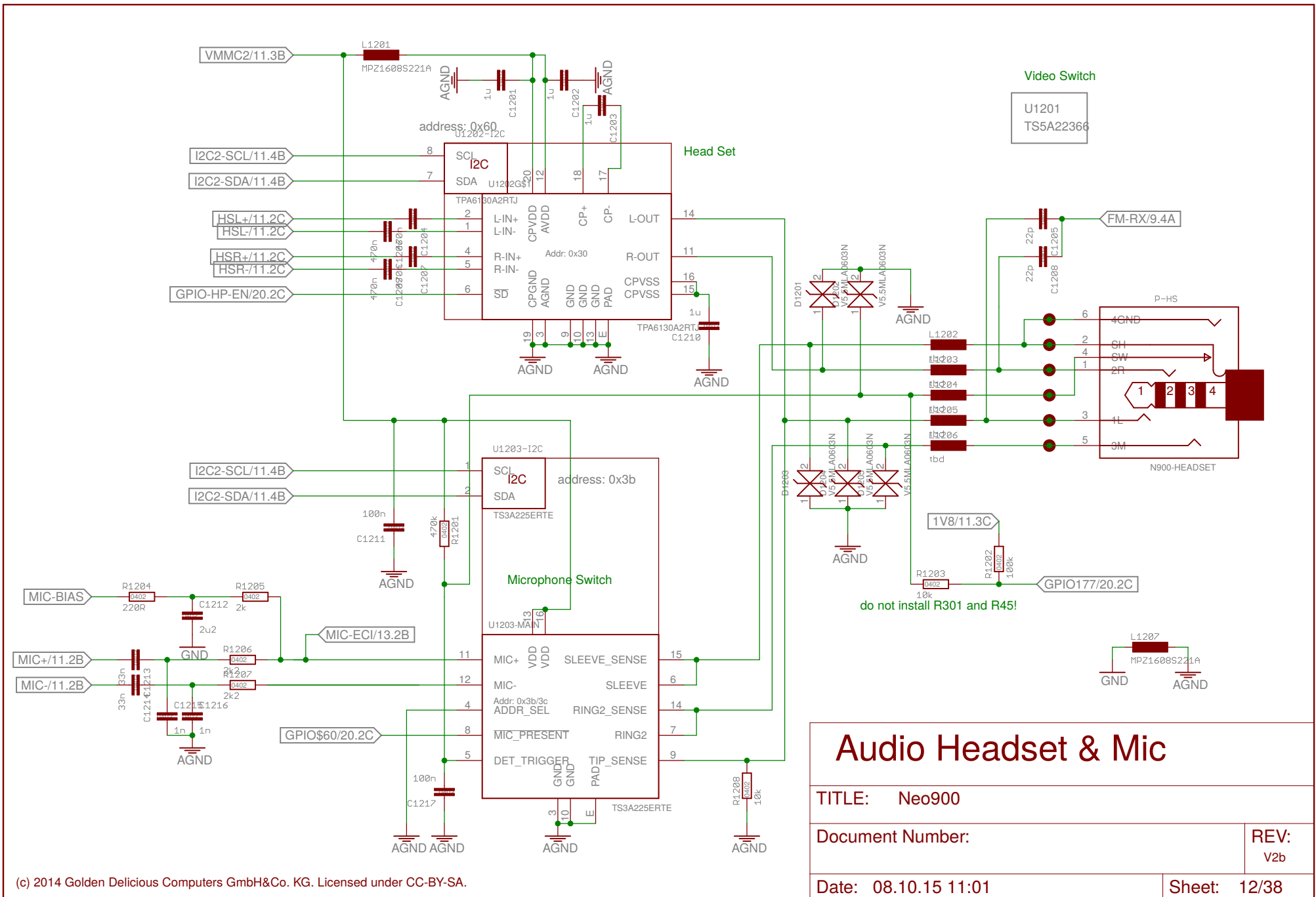

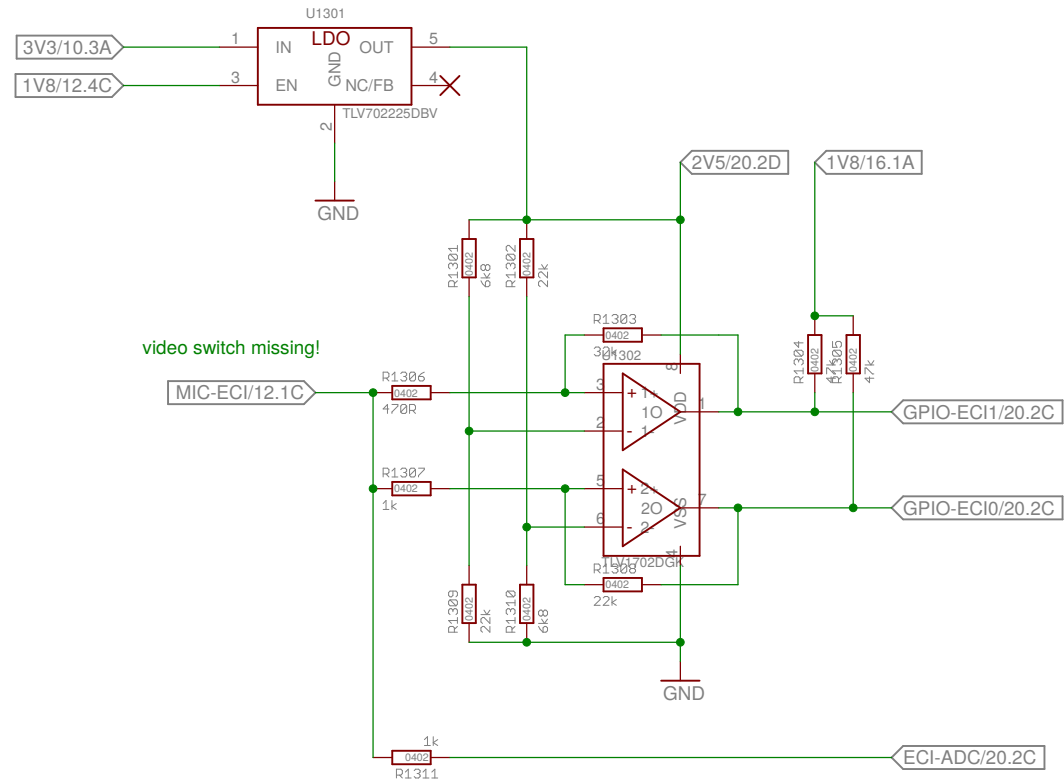

# ECI

TITLE: Neo900

Document Number:

REV:  
V2b

Date: 08.10.15 11:01

Sheet: 13/38



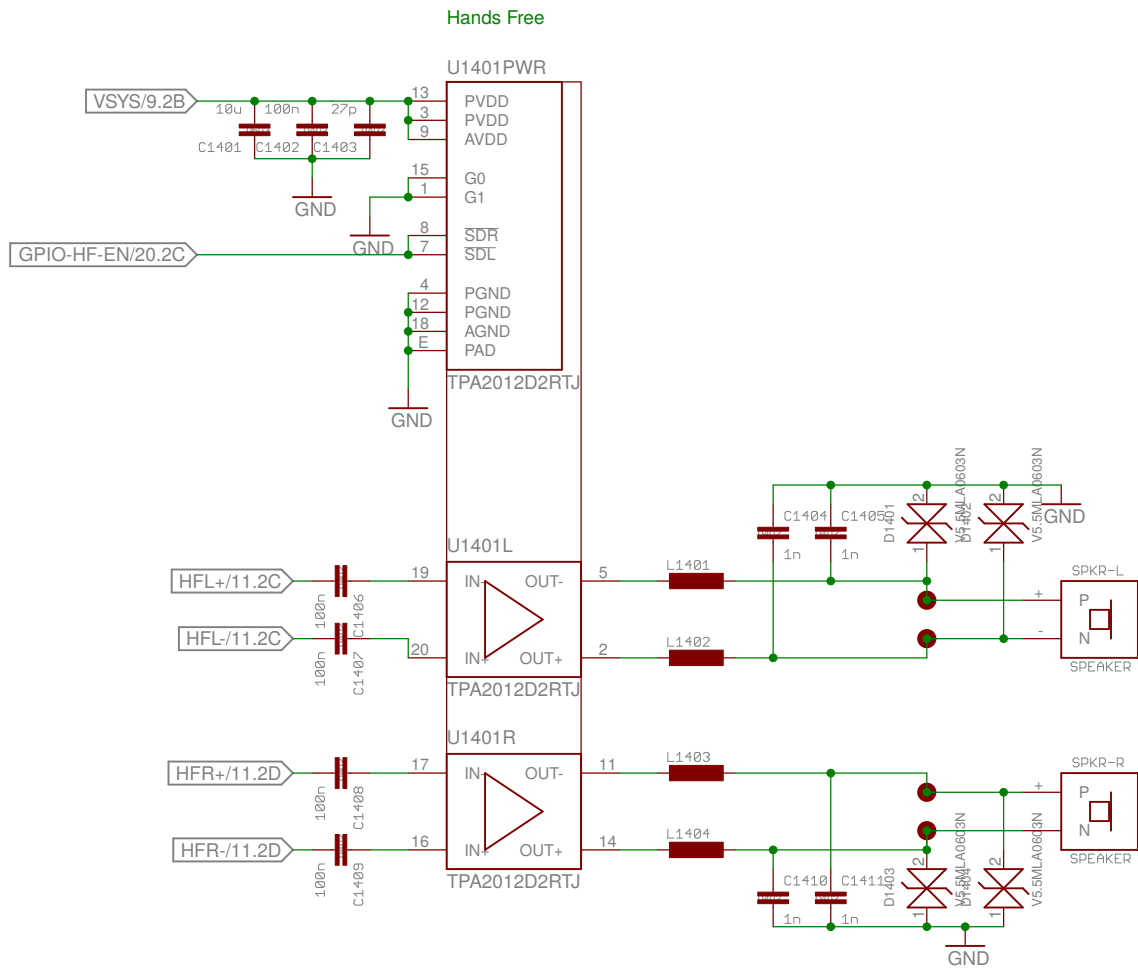

# Audio Handsfree

TITLE: Neo900

Document Number:

REV:  
V2b

Date: 08.10.15 11:01

Sheet: 14/38

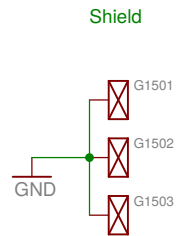
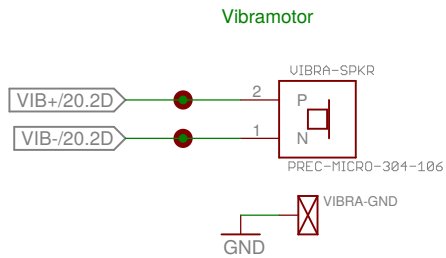
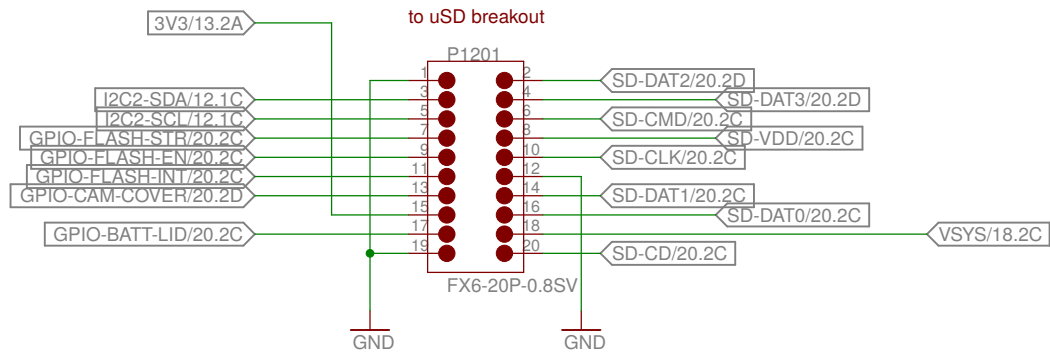

## Misc (lower)

TITLE: Neo900

Document Number:

REV:  
V2b

Date: 08.10.15 11:01

Sheet: 15/38

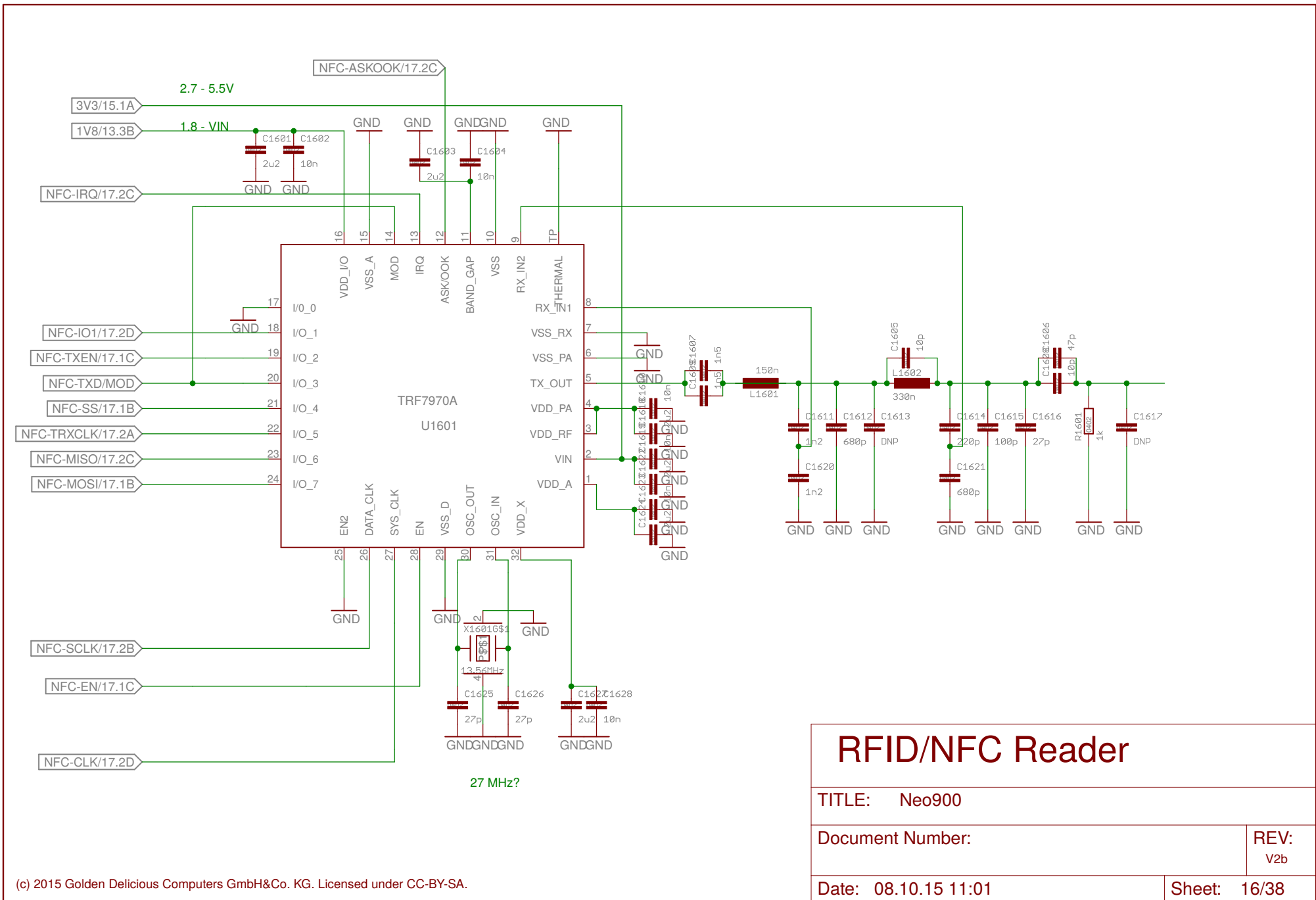

# RFID/NFC Reader

TITLE: Neo900

Document Number:

REV:  
V2b

Date: 08.10.15 11:01

Sheet: 16/38

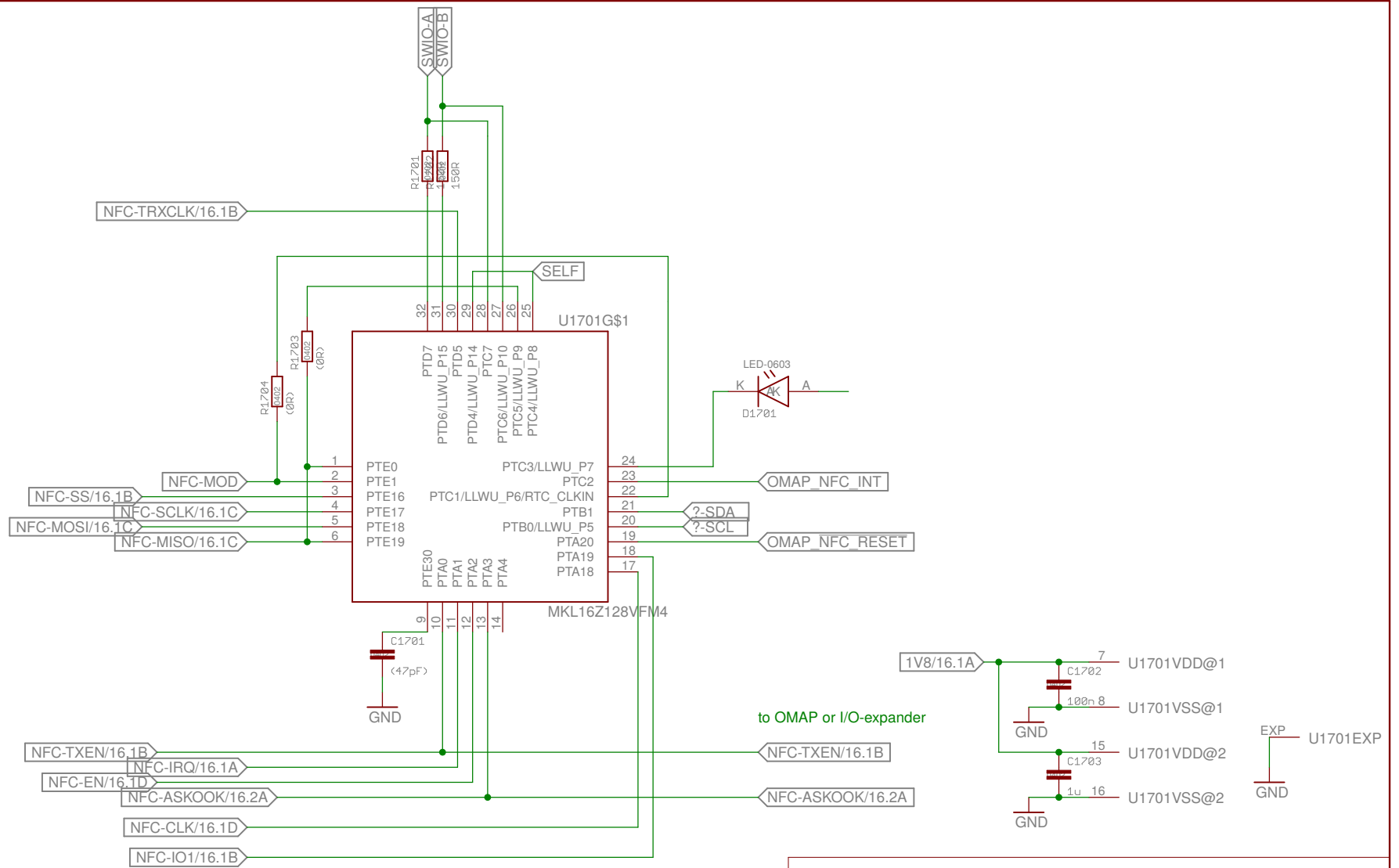

# RFID/NFC Controller

TITLE: Neo900

Document Number:

REV:  
V2b

Date: 08.10.15 11:01

Sheet: 17/38

NOTE: this is mangling up Breakout and Lower board connectors  
 Signals may have to be fed through the breakout board connector increasing resistance

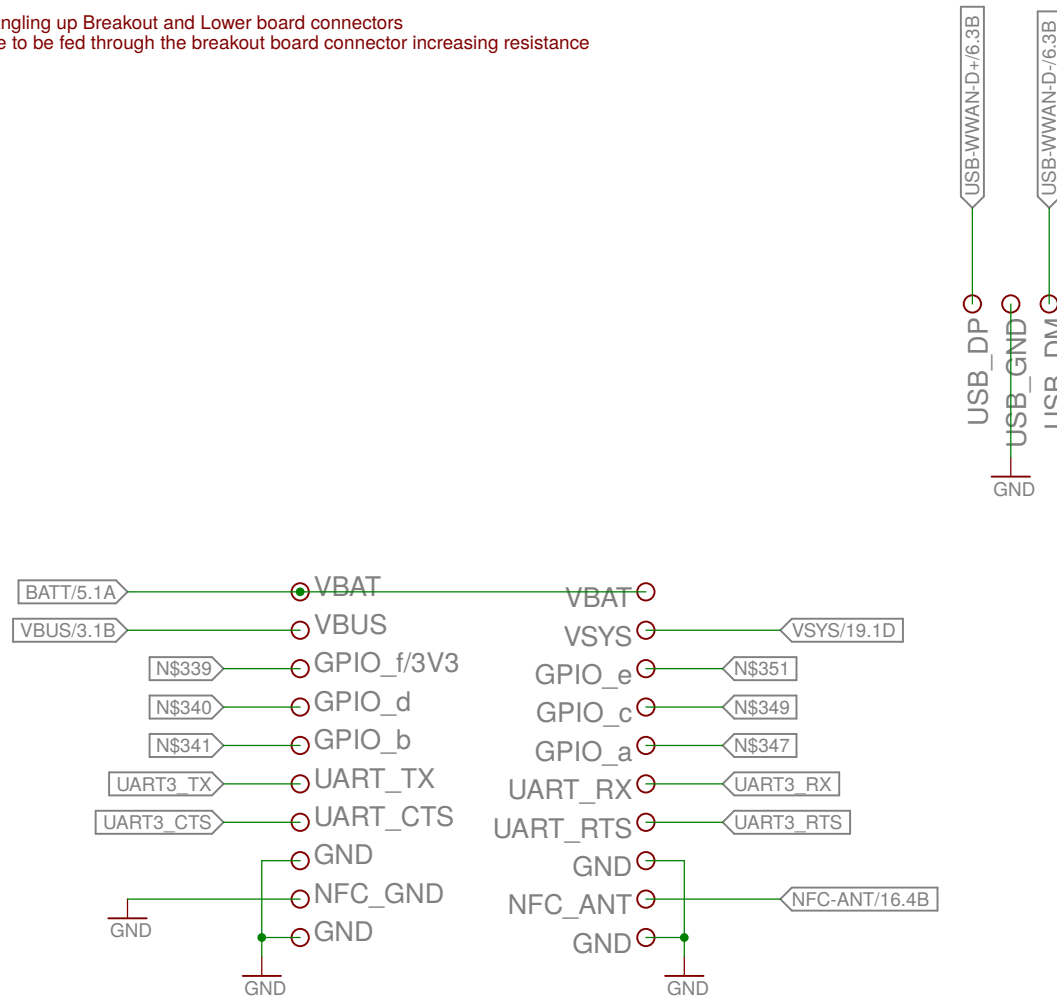

Missing 10 level shifter chip (or do we really have the space for 10x discrete T+R+D ca. 3x3mm each?)

Missing 6x 2R for alternate function select (do we have the space for ca. 2.5 x 5mm?)

# Hackerbus

TITLE: Neo900

Document Number:

REV:  
V2b

Date: 08.10.15 11:01

Sheet: 18/38

NOTE: 1V8 may be quite noisy!

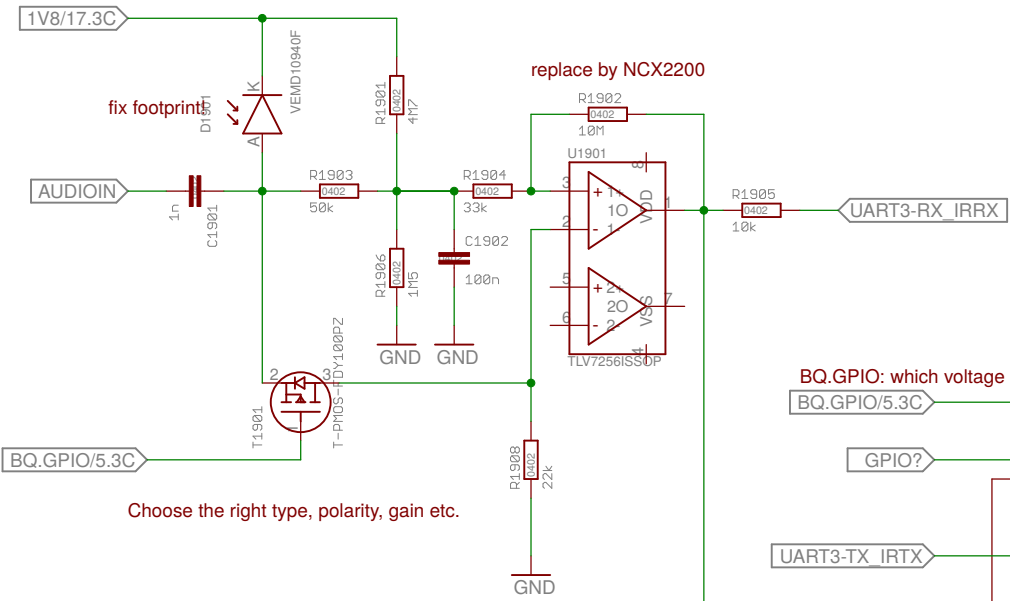

fix footprint

replace by NCX2200

Choose the right type, polarity, gain etc.

BQ.GPIO: which voltage level?

BQ.GPIO/5.3C

GPIO?

UART3-TX\_IRTX

UART3-CTS\_RCTX

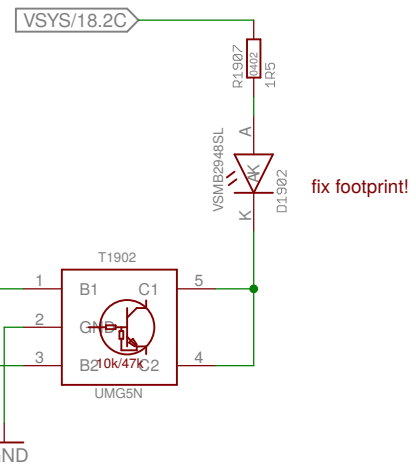

fix footprint!

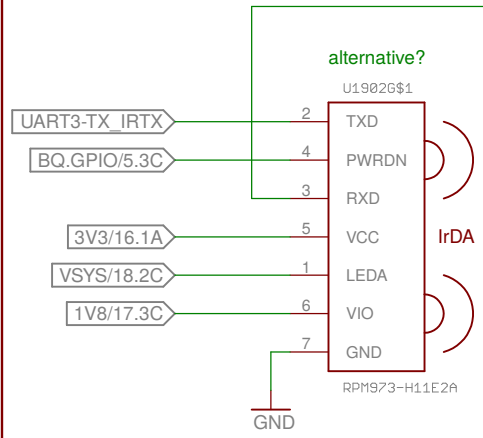

alternative?

IrDA

# Infrared

TITLE: Neo900	
Document Number:	REV: V2b
Date: 08.10.15 11:01	Sheet: 19/38

ca. 130 signals (to be counted exactly after definition of upper/lower split)

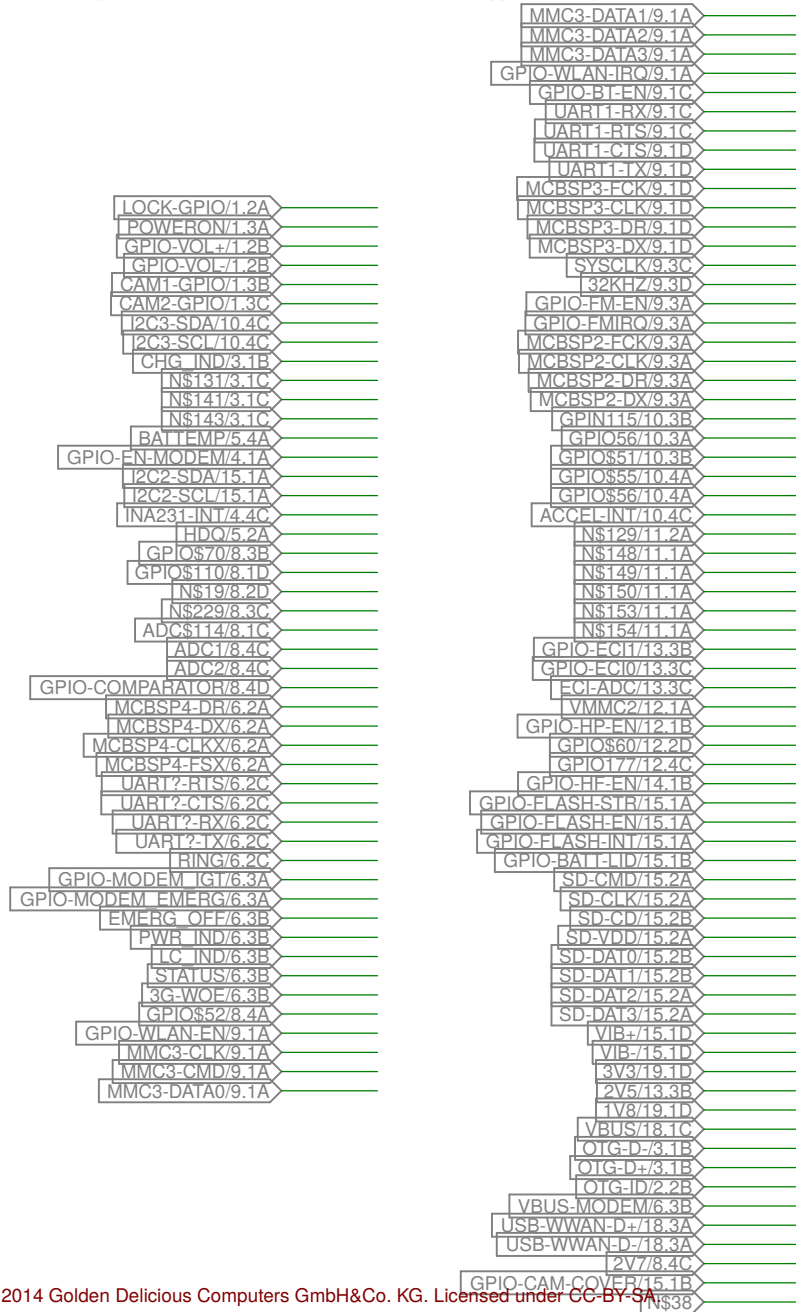

Pin assignment must be optimized for final component placement  
we might have to switch to 80 or 100 pin connectors

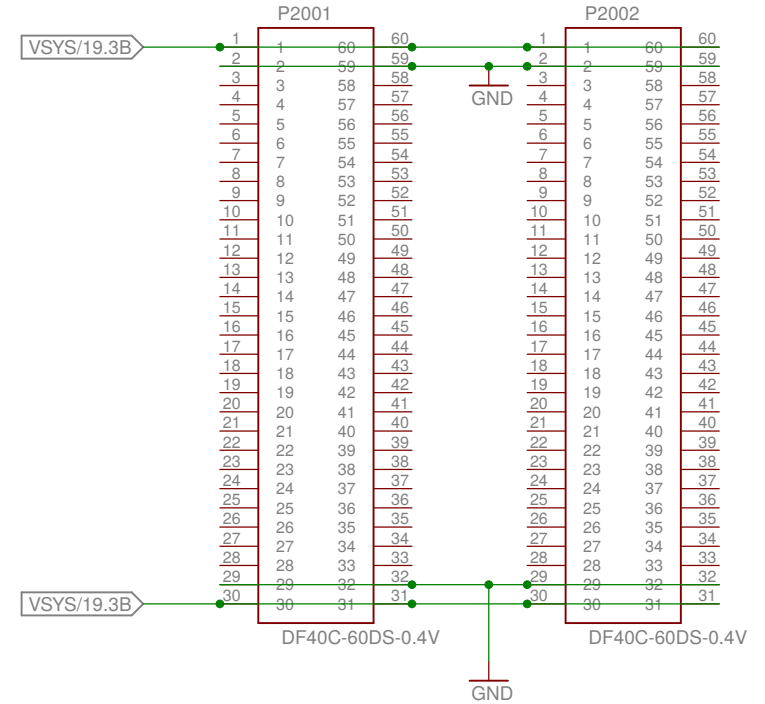

## B2B to upper board

TITLE: Neo900

Document Number:

REV:  
V2b

Date: 08.10.15 11:01

Sheet: 20/38

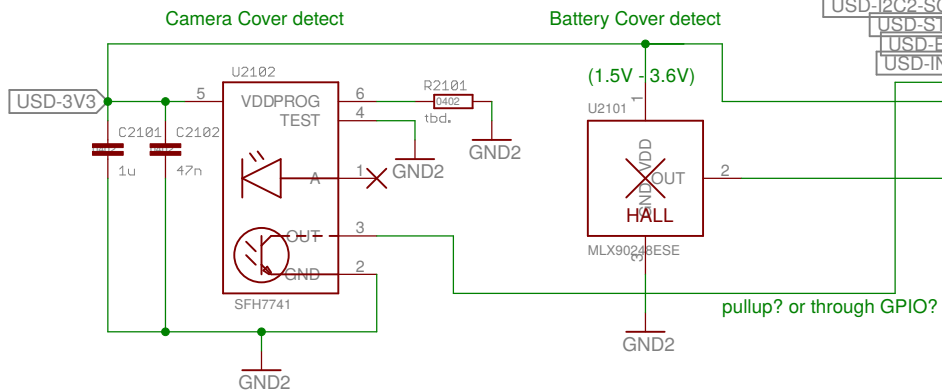

USD-I2C2-SDA  
 USD-I2C2-SCL  
 USD-STR  
 USD-EN  
 USD-INT

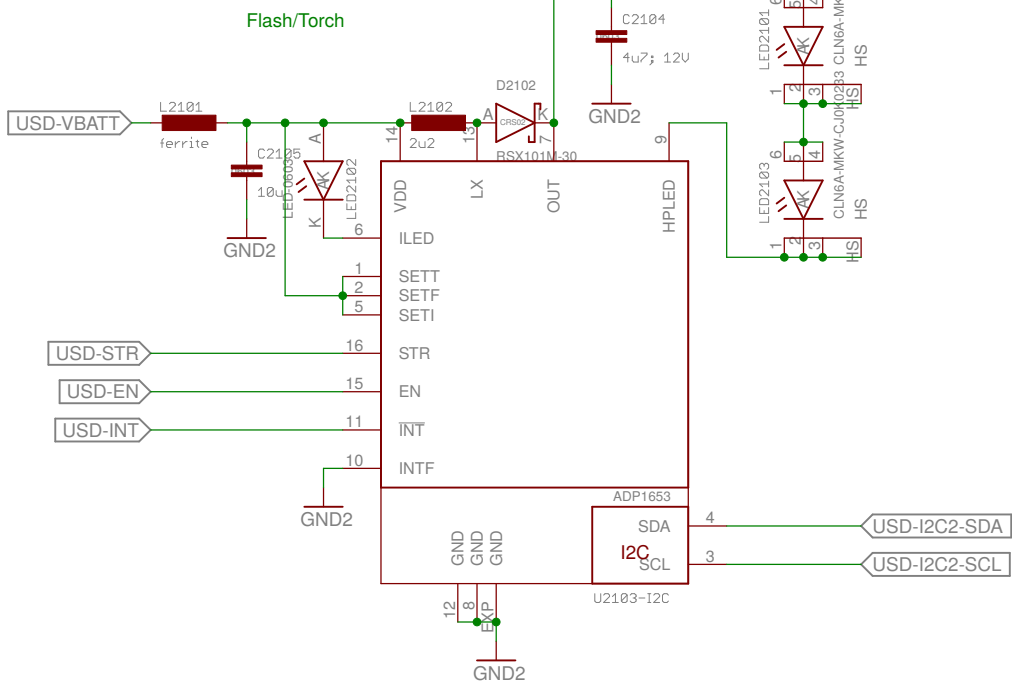
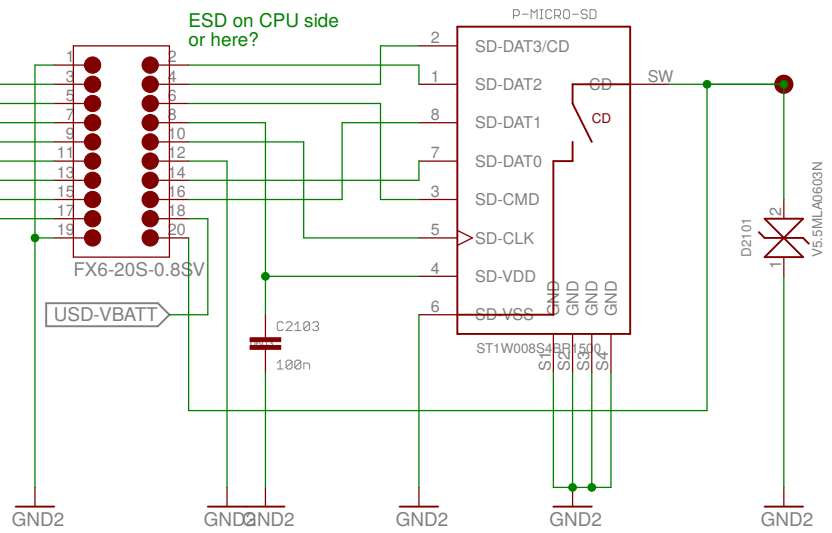

# µSD Breakout Board

TITLE: Neo900	
Document Number:	REV: V2b
Date: 08.10.15 11:01	Sheet: 21/38



to be adjusted to lower board connector

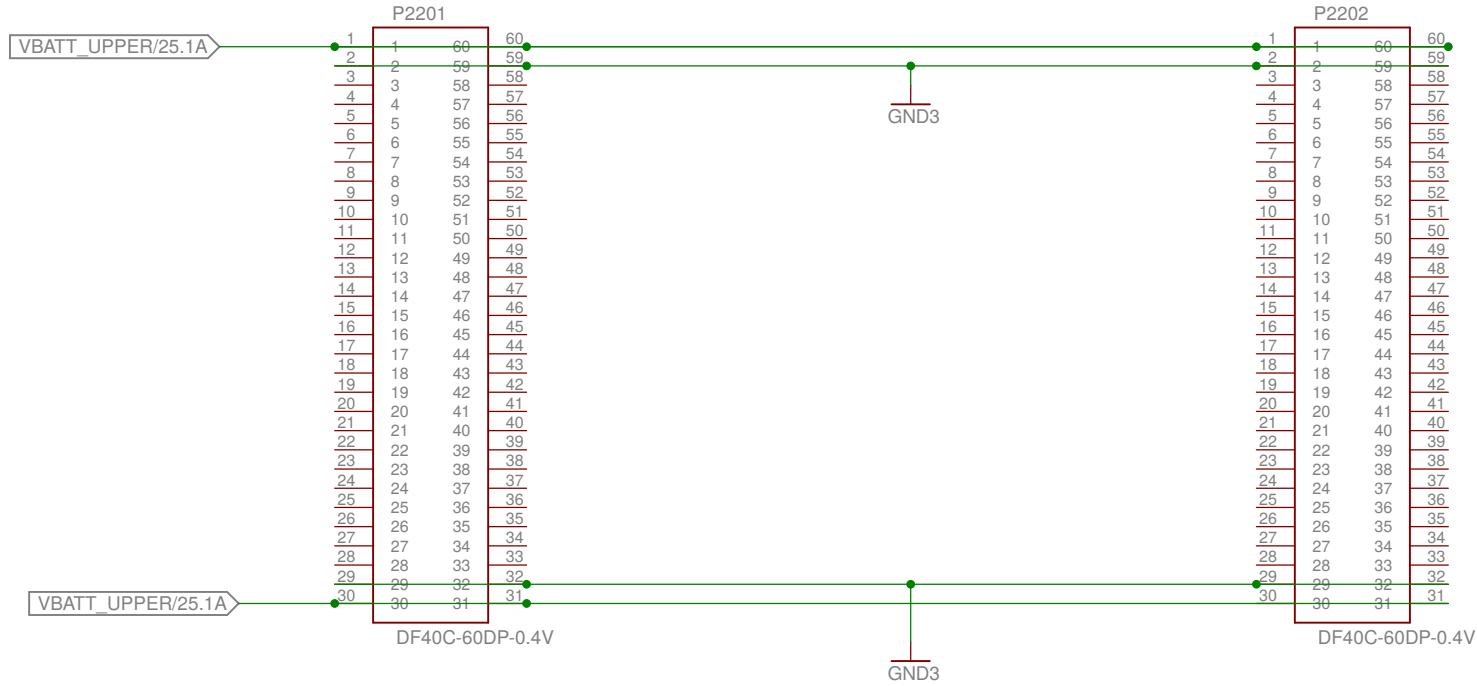

SHIELD

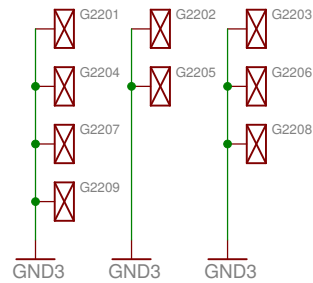

# B2B to lower board

TITLE: Neo900

Document Number:

REV:  
V2b

Date: 08.10.15 11:01

Sheet: 22/38

needs final tuning (which button on which position)

VOL+ and VOL- could drive FETs sitting in the matrix

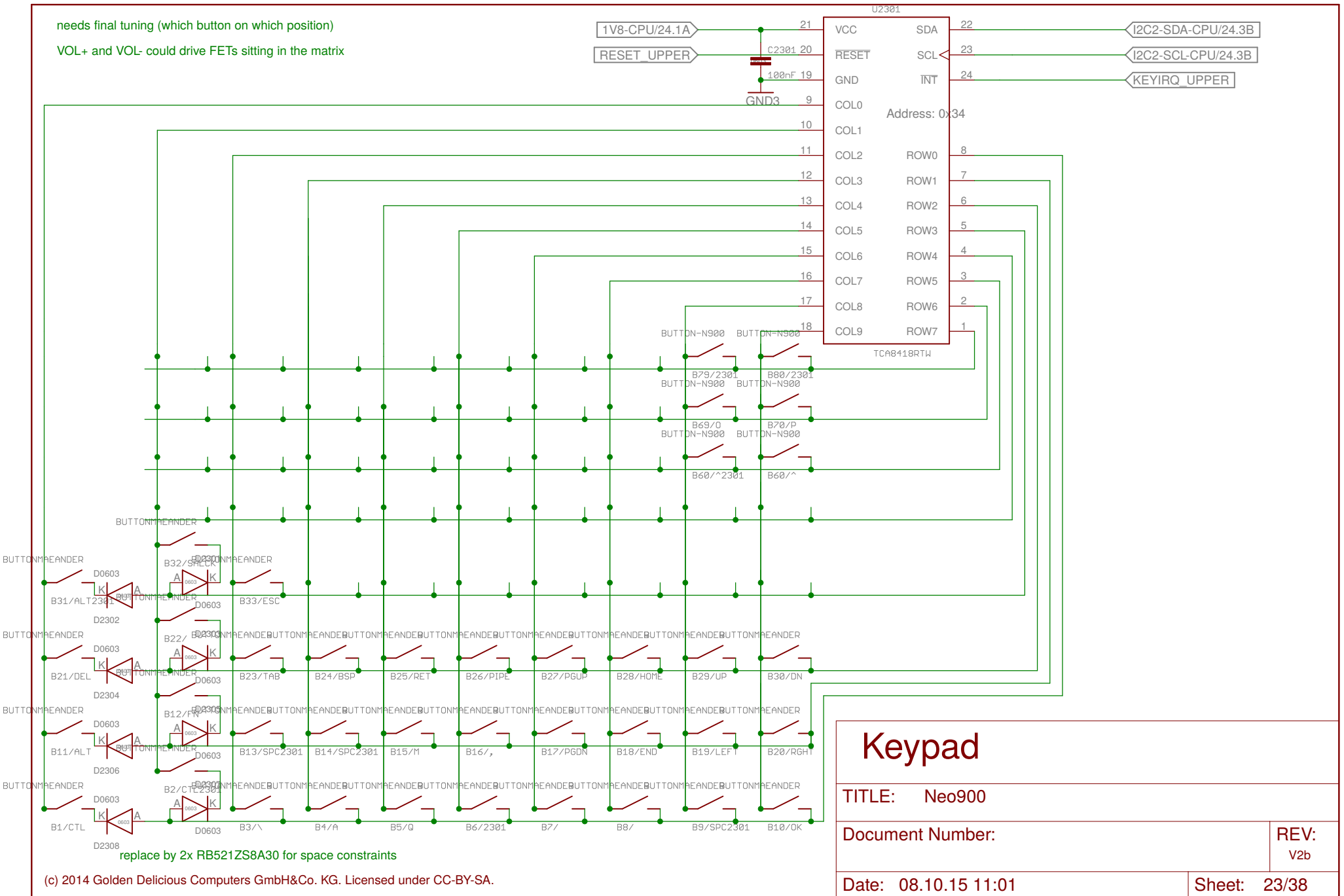

# Keypad

TITLE: Neo900

Document Number:

REV:  
V2b

Date: 08.10.15 11:01

Sheet: 23/38

replace by 2x RB521ZS8A30 for space constraints

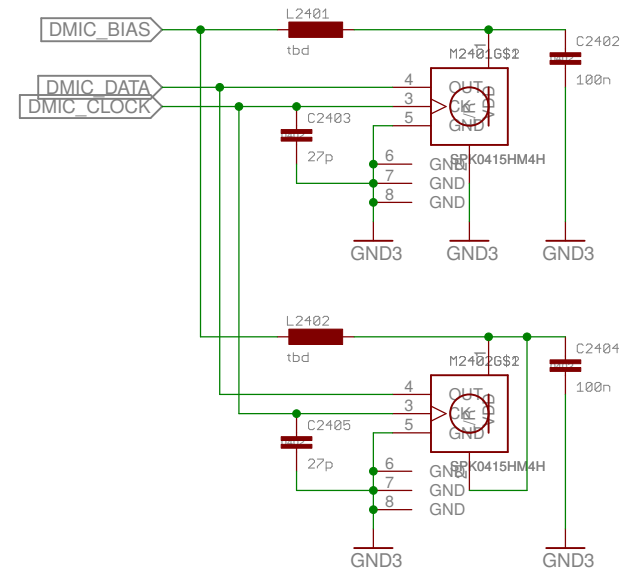
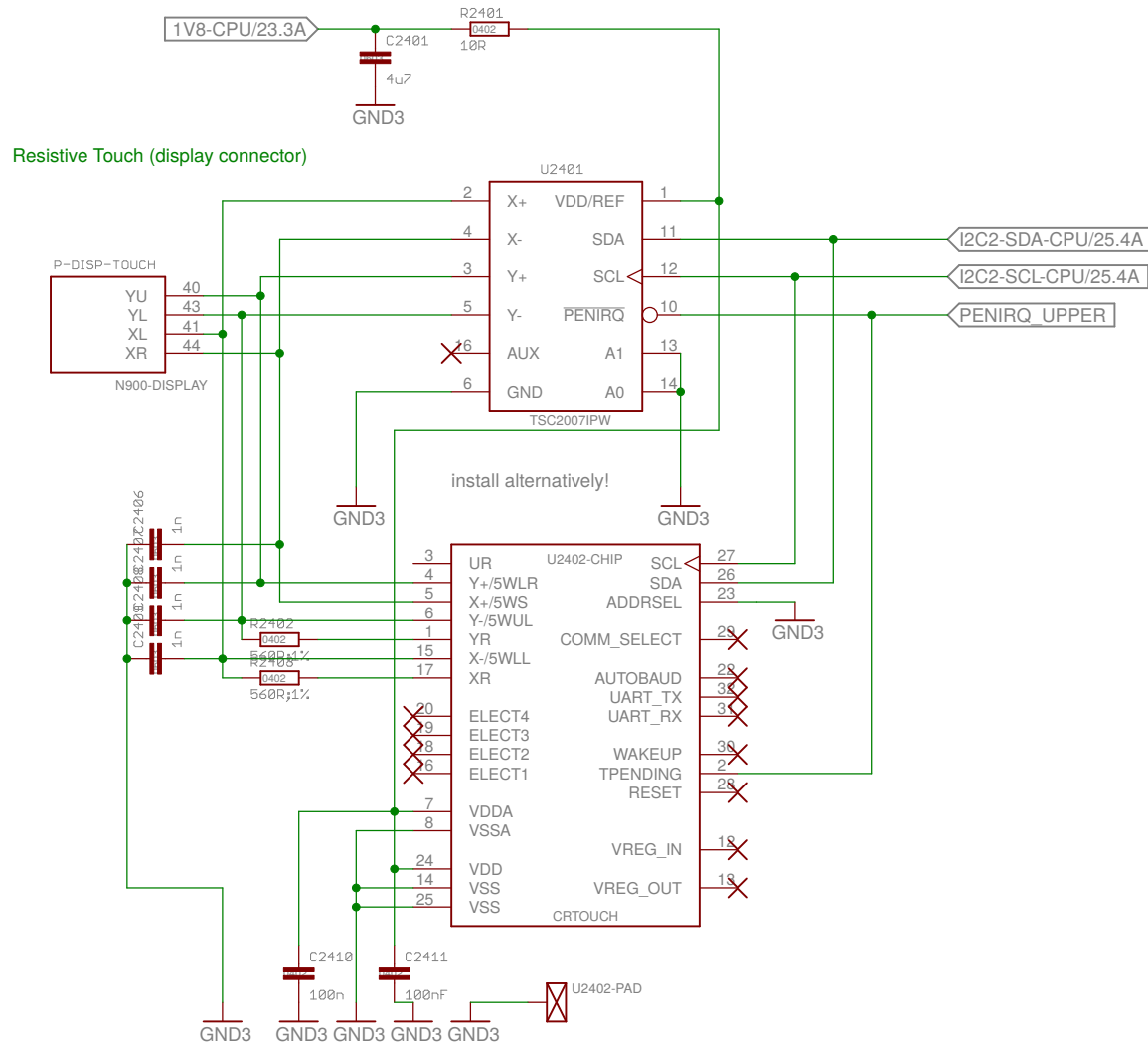

## Display-Peripherals

TITLE: Neo900

Document Number:

REV:  
V2b

Date: 08.10.15 11:01

Sheet: 24/38

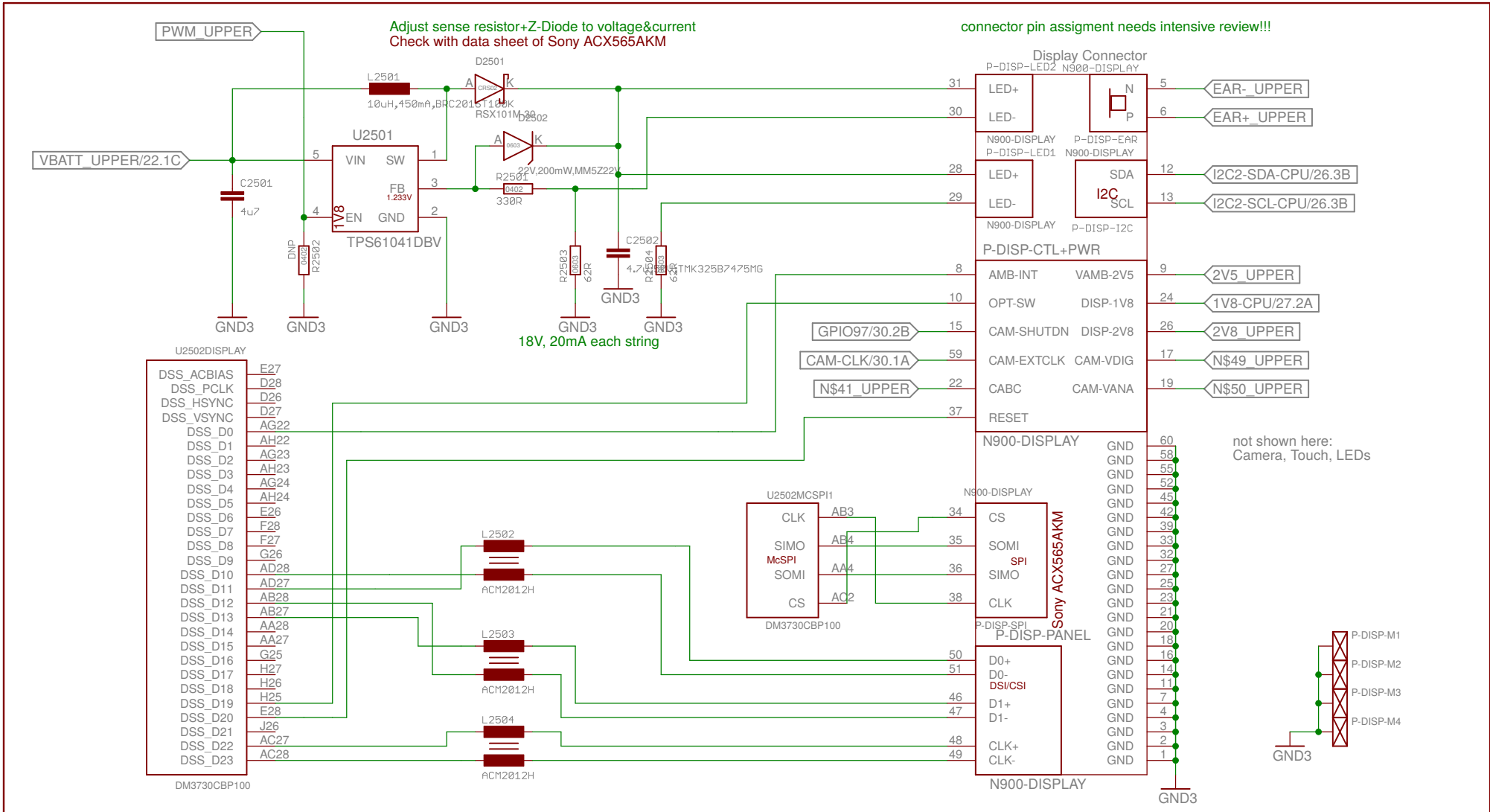

# Display-Panel&Power

TITLE: Neo900	
Document Number:	REV: V2b
Date: 08.10.15 11:01	Sheet: 25/38

(c) 2014 Golden Delicious Computers GmbH&Co. KG. Licensed under CC-BY-SA.

INCOMPLETE in V2

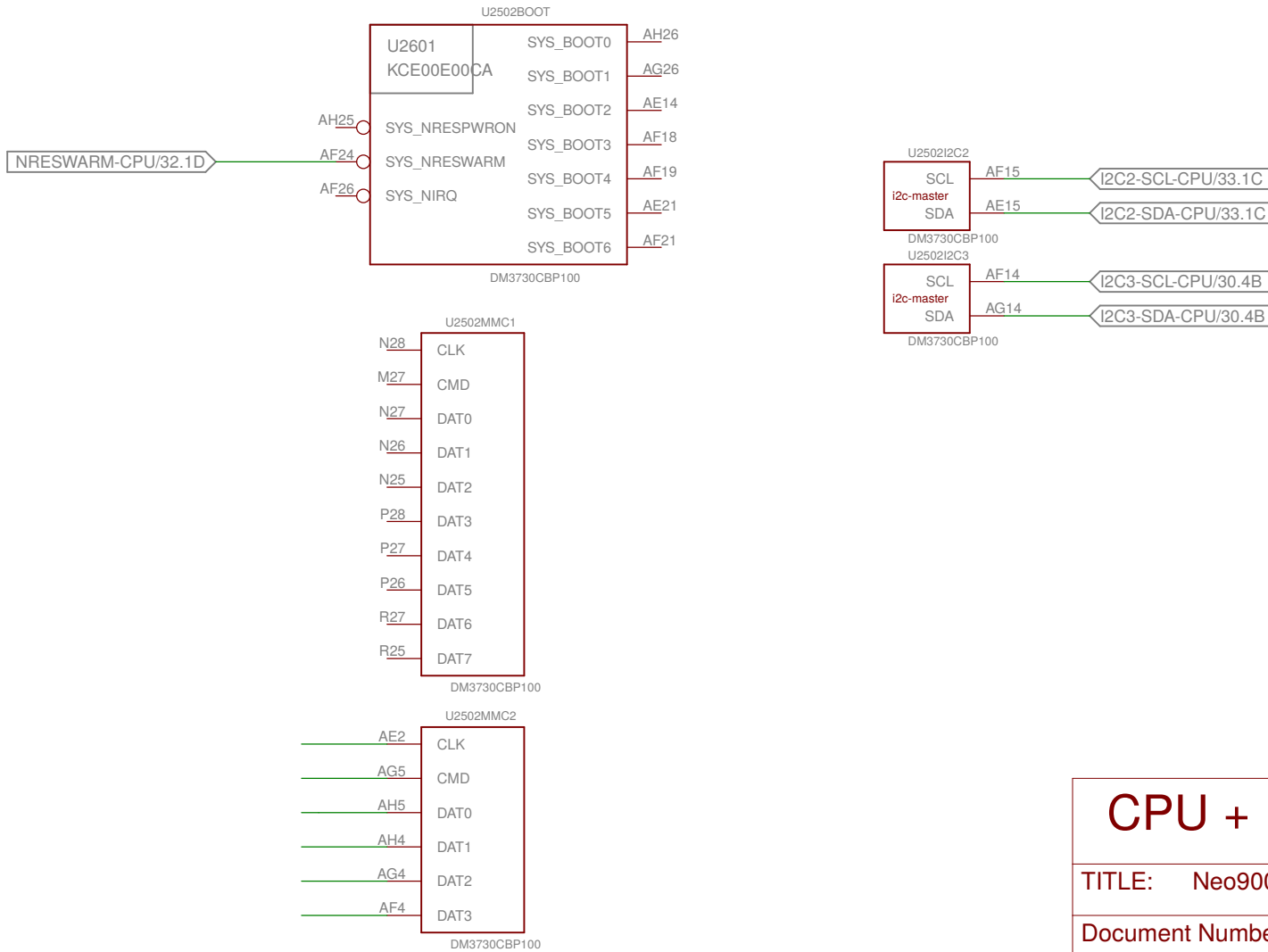

# CPU + PoP RAM/NAND

TITLE: Neo900

Document Number:

REV:  
V2b

Date: 08.10.15 11:01

Sheet: 26/38

INCOMPLETE in V2

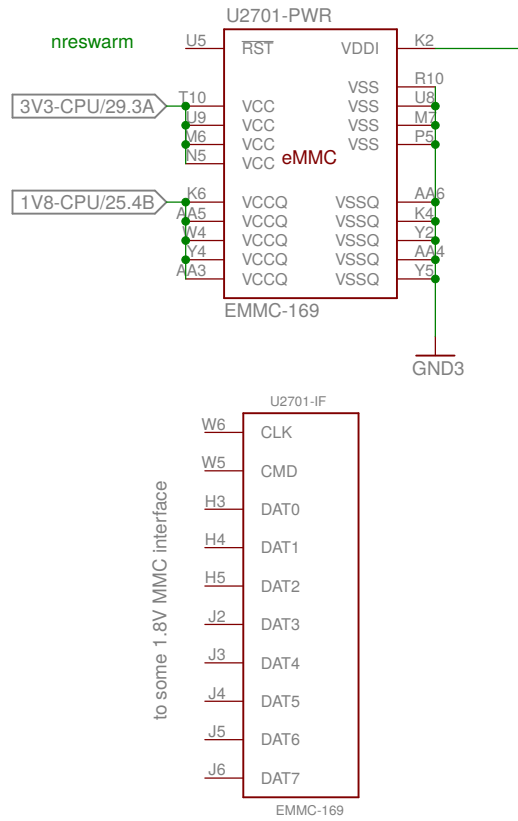

# eMMC

TITLE: Neo900

Document Number:

REV:  
V2b

Date: 08.10.15 11:01

Sheet: 27/38

INCOMPLETE in V2

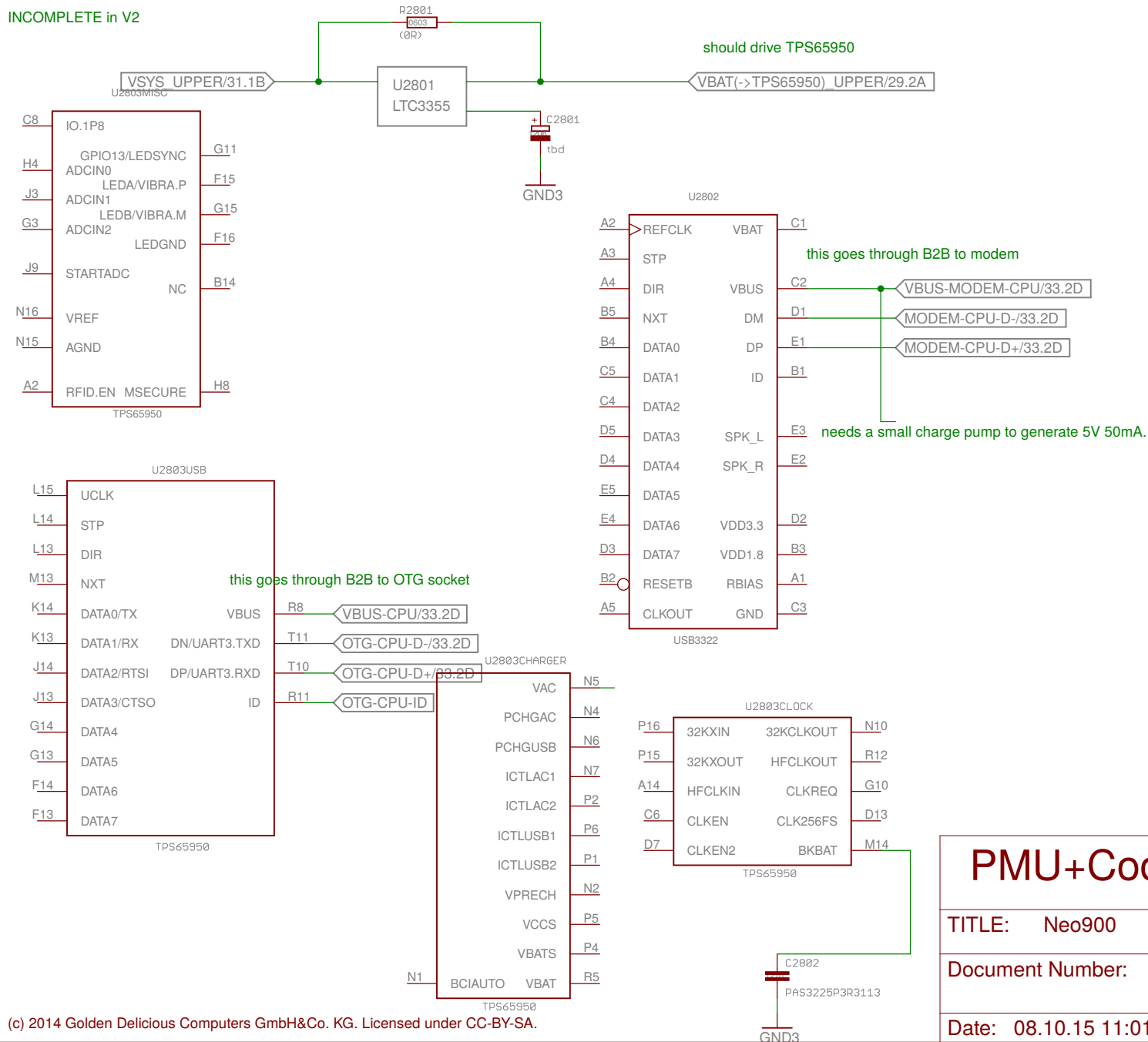

# PMU+Codec

TITLE: Neo900

Document Number:

REV:  
V2b

Date: 08.10.15 11:01

Sheet: 28/38

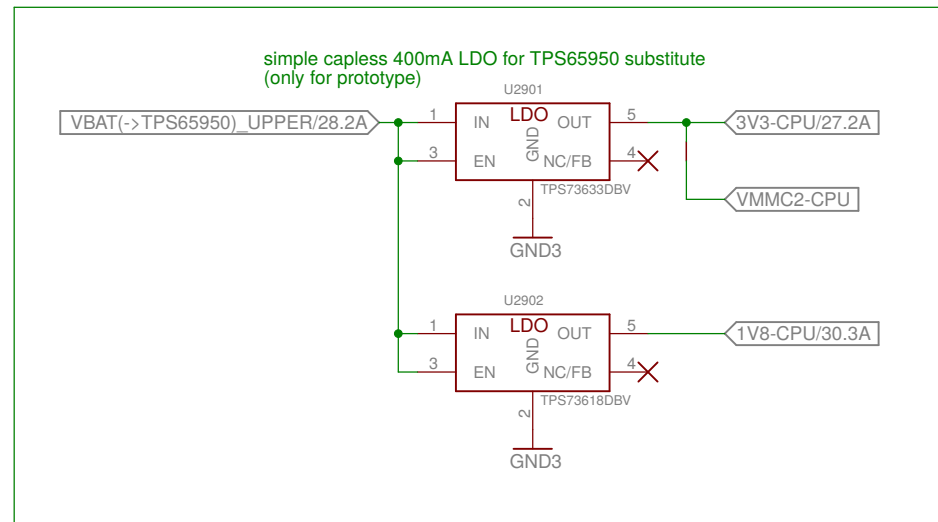

## BB-XM Dummy (TWL4030)

TITLE: Neo900

Document Number:

REV:  
V2b

Date: 08.10.15 11:01

Sheet: 29/38



INCOMPLETE in V2

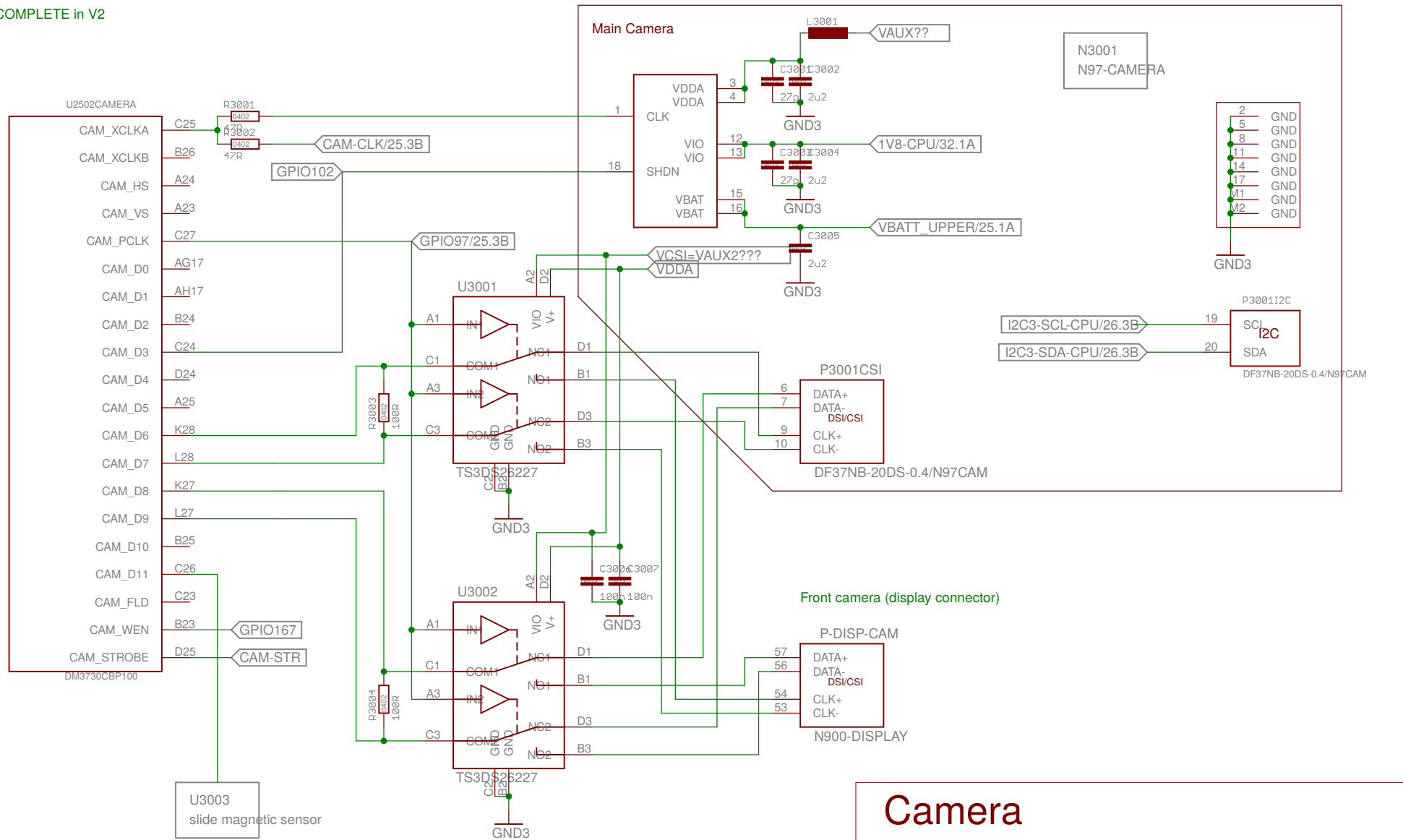

# Camera

TITLE: Neo900	
Document Number:	REV: V2b
Date: 08.10.15 11:01	Sheet: 30/38

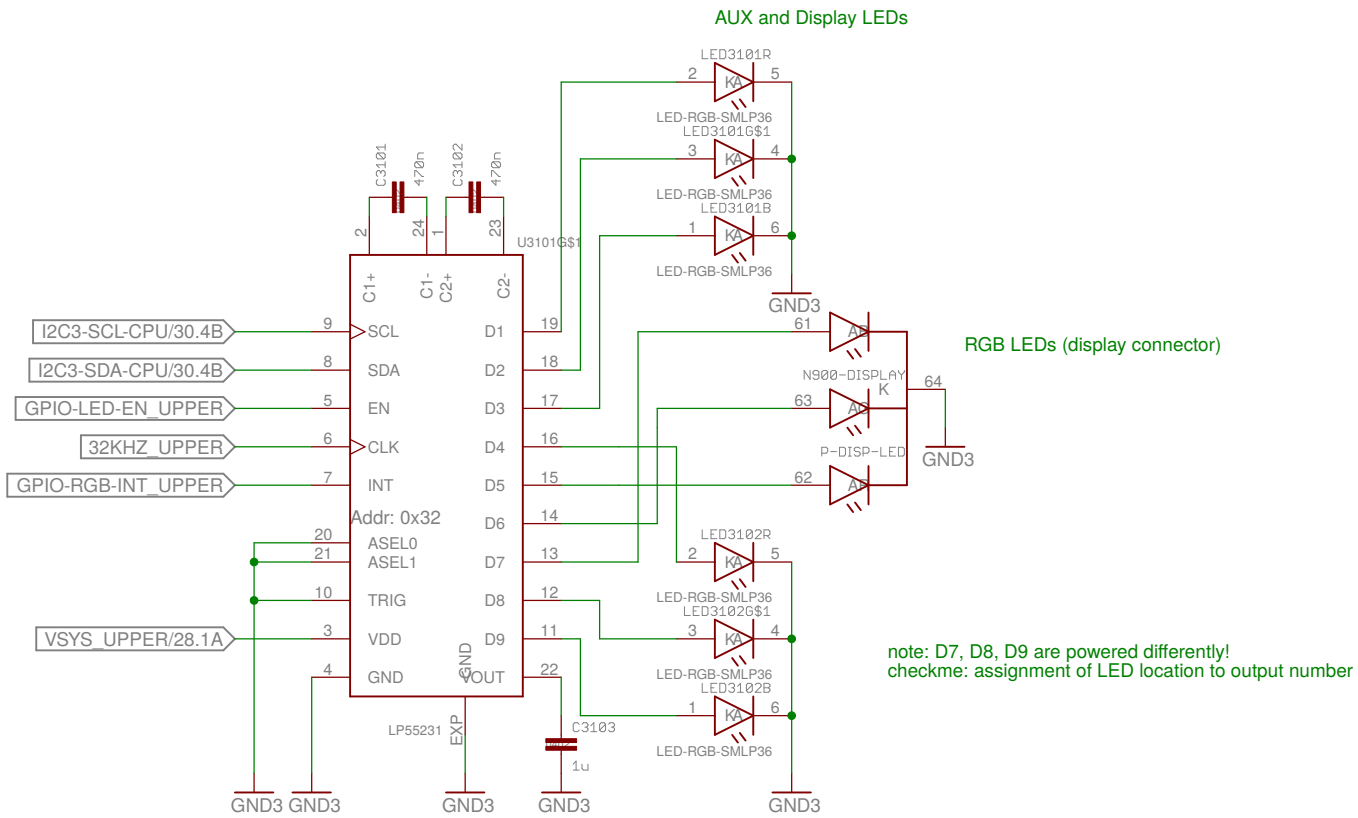

# LEDs

TITLE: Neo900

Document Number:

REV:  
V2b

Date: 08.10.15 11:01

Sheet: 31/38

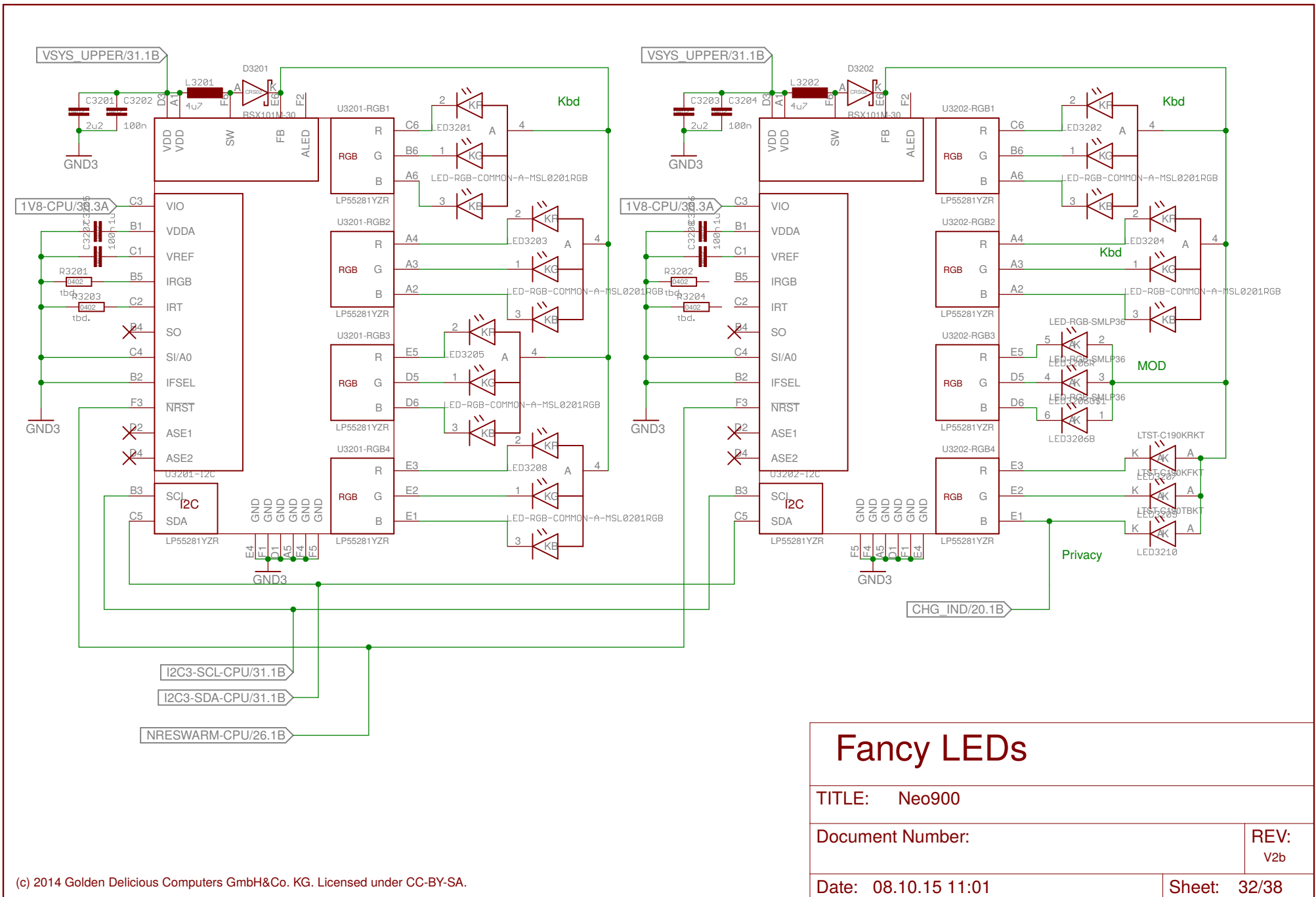

# Fancy LEDs

TITLE: Neo900

Document Number:

REV:  
V2b

Date: 08.10.15 11:01

Sheet: 32/38

These connectors allow to "emulate" the DM3730 by connecting a BB-XM

INCOMPLETE  
prototype only

connect to respective CPU-pads

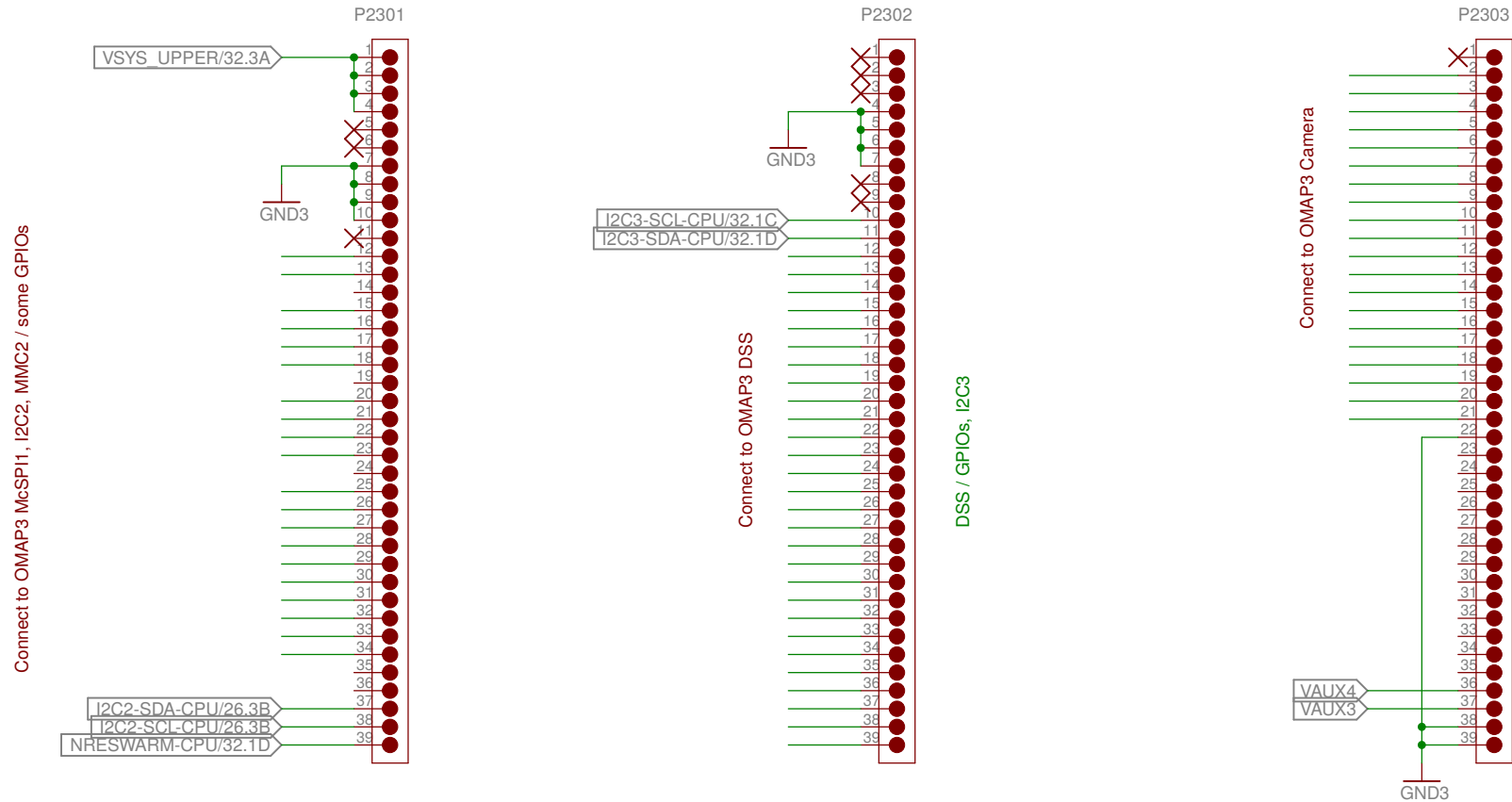

connect to BB  
by some Micro-USB cable

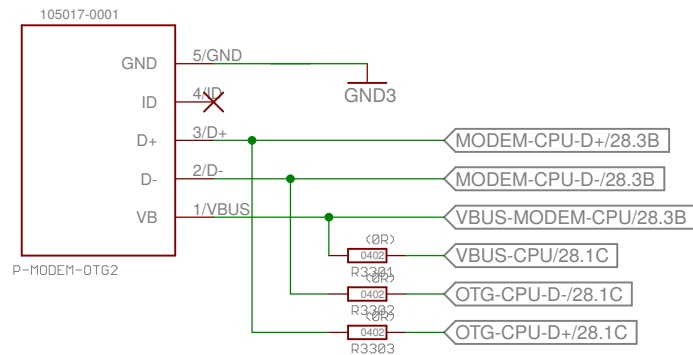

# Connector to BB

TITLE: Neo900

Document Number:

REV:  
V2b

Date: 08.10.15 11:01

Sheet: 33/38

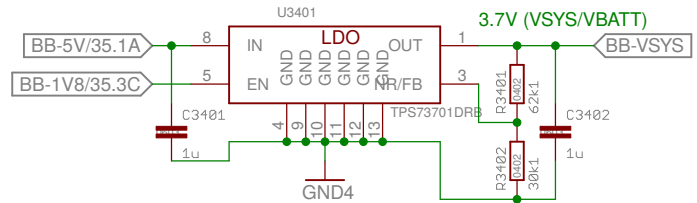

Ersetzen durch 2A buck converter

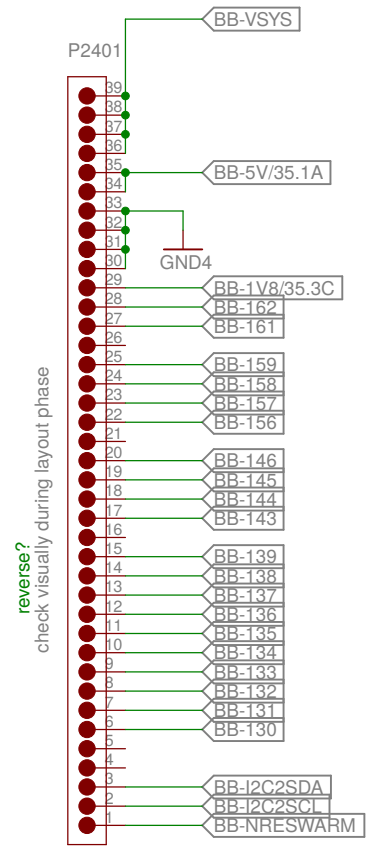

reverse?  
check visually during layout phase

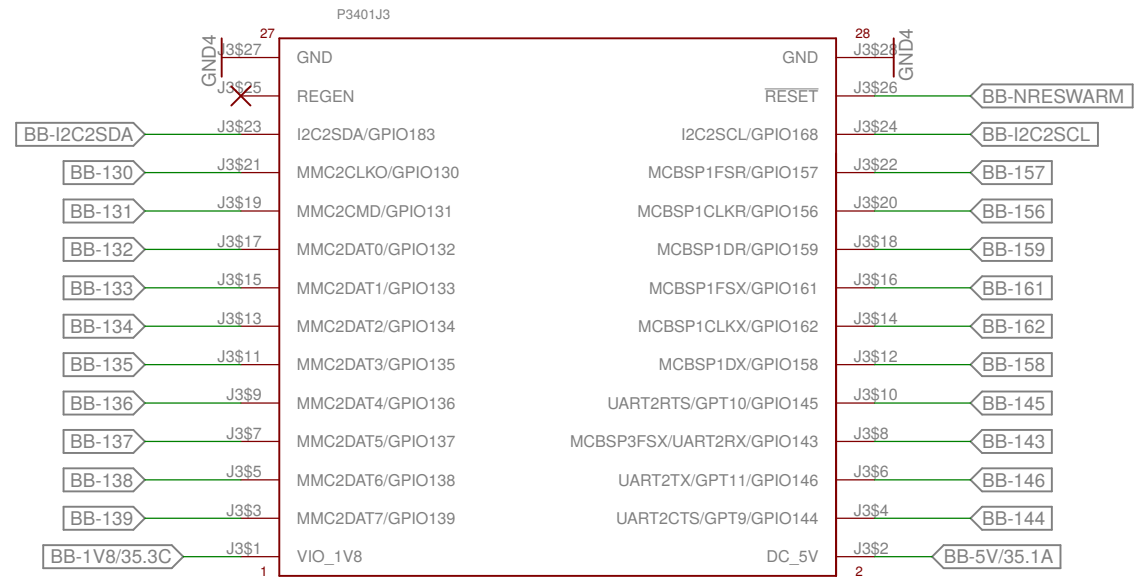

Top View on BB

# BB-XM Adapter (CPU)

TITLE: Neo900

Document Number:

REV:  
V2b

Date: 08.10.15 11:01

Sheet: 34/38

reverse?  
check visually during layout phase

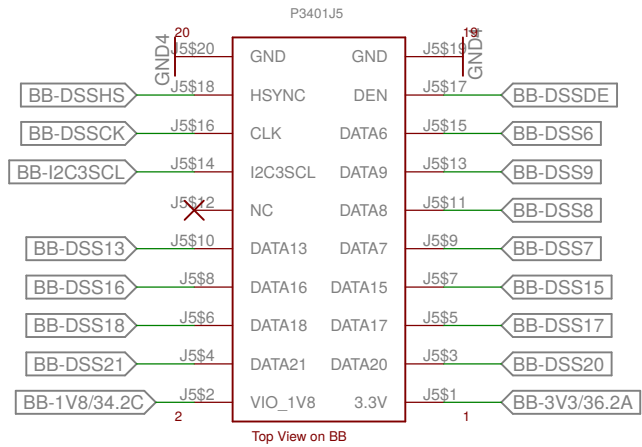
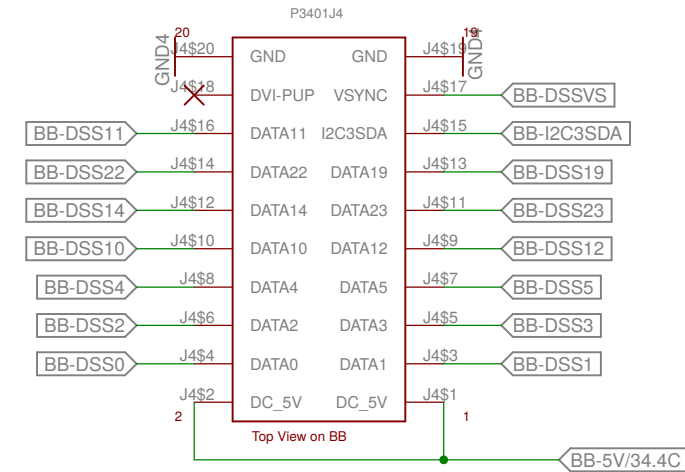
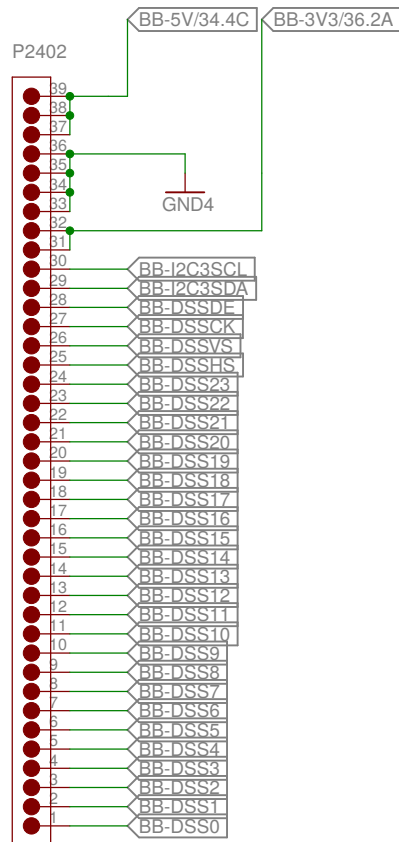

# BB-XM Adapter (DISP)

TITLE: Neo900

Document Number:

REV:  
V2b

Date: 08.10.15 11:01

Sheet: 35/38

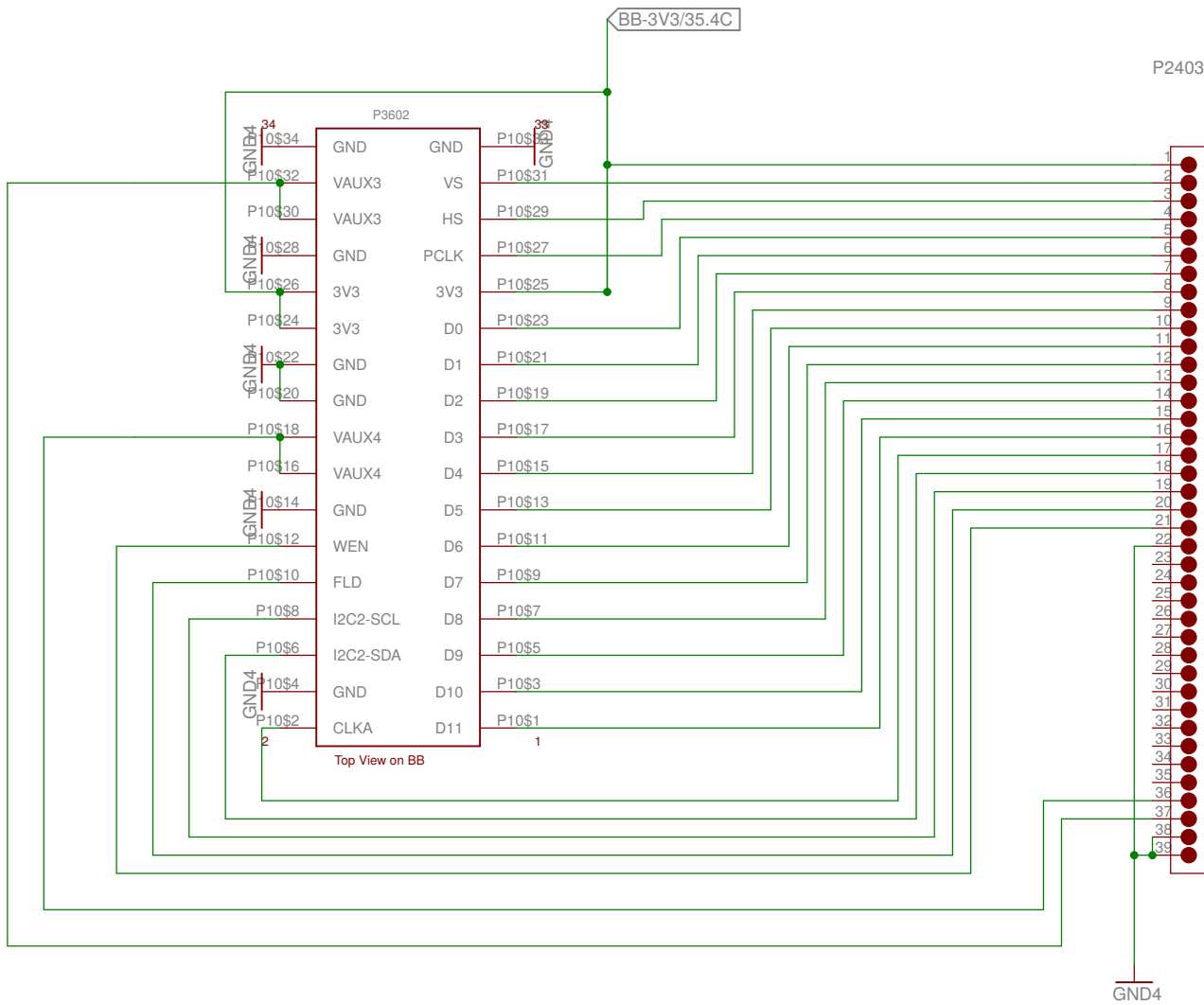

reverse?  
check visually during layout phase

# BB-XM Adapter (CAM)

TITLE: Neo900

Document Number:

REV:  
V2b

Date: 08.10.15 11:01

Sheet: 36/38

Molex Jumper cables to connect BB-XM-Adapter to Uppwer board

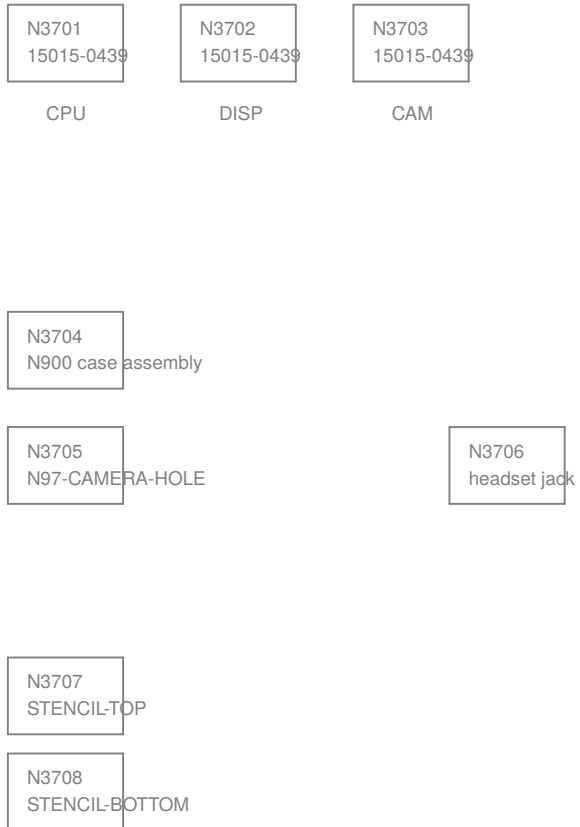

## No-Solder Components

TITLE: Neo900

Document Number:

REV:  
V2b

Date: 08.10.15 11:01

Sheet: 37/38



- 1: Buttons
- 2: OTG
- 3: Charger/OTG-Booster
- 5: Fuel Gauge
- 6: 3G/4G Modem + SIM
- 7: Dual SIM switch
- 8: Antenna connections
- 9: WLAN & Bluetooth & FM
- 10: Sensors
- 11: Audio Codec
- 12: Audio Headset & Mic
- 13: ECI
- 14: Audio Handsfree
- 15: Misc (lower)
- 16: RFID/NFC Reader
- 17: RFID/NFC Controller
- 18: Hackerbus
- 19: Infrared
- 20: B2B to upper board
- 21:  $\mu$ SD Breakout Board
- 22: B2B to lower board
- 23: Keypad
- 24: Display-Peripherals
- 25: Display-Panel&Power
- 26: CPU + PoP RAM/NAND
- 27: eMMC
- 28: PMU+Codec
- 29: BB-XM Dummy (TWL4030)
- 30: Camera
- 31: LEDs
- 32: Fancy LEDs
- 33: Connector to BB
- 34: BB-XM Adapter (CPU)
- 35: BB-XM Adapter (DISP)
- 36: BB-XM Adapter (CAM)
- 37: No-Solder Components
- 38: Table of Contents

## Table of Contents

TITLE: Neo900	
Document Number:	REV: V2b
Date: 08.10.15 11:01	Sheet: 38/38