



© 2000 Bentley Systems, Incorporated



© 2000 Bentley Systems, Incorporated



© 2000 Bentley Systems, Incorporated



© 2000 Bentley Systems, Incorporated



© 2000 Bentley Systems, Incorporated

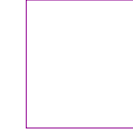

© 2000 Bentley Systems, Incorporated

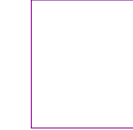

© 2000 Bentley Systems, Incorporated

Steel Deck Connections



© 2000 Bentley Systems, Incorporated

Steel Deck Headers TH



© 2000 Bentley Systems, Incorporated

Steel Joists



© 2000 Bentley Systems, Incorporated

Steel Deck Sides



© 2000 Bentley Systems, Incorporated

Steel Deck Headers - H



© 2000 Bentley Systems, Incorporated

Steel I



© 2000 Bentley Systems, Incorporated

Steel Deck Headers



© 2000 Bentley Systems, Incorporated

Steel Joists



© 2000 Bentley Systems, Incorporated

Steel Deck Headers



© 2000 Bentley Systems, Incorporated

Steel Deck Headers



© 2000 Bentley Systems, Incorporated

Steel Joists



© 2000 Bentley Systems, Incorporated

Steel Joist



© 2000 Bentley Systems, Incorporated

Steel Deck Headers



© 2000 Bentley Systems, Incorporated

Steel Deck Headers



© 2000 Bentley Systems, Incorporated

Steel Deck Headers



© 2000 Bentley Systems, Incorporated

Steel Joist



© 2000 Bentley Systems, Incorporated

Steel Deck Headers



© 2000 Bentley Systems, Incorporated

Steel Deck Headers



© 2000 Bentley Systems, Incorporated

Steel Deck Headers



© 2000 Bentley Systems, Incorporated

Steel Deck



© 2000 Bentley Systems, Incorporated

Steel Deck Sides



© 2000 Bentley Systems, Incorporated

Steel Deck Headers - H



© 2000 Bentley Systems, Incorporated

Steel Joist



© 2000 Bentley Systems, Incorporated

Steel Deck



© 2000 Bentley Systems, Incorporated

Steel Joist



© 2000 Bentley Systems, Incorporated

Steel Deck Headers - H



© 2000 Bentley Systems, Incorporated

Steel Deck Headers - H



© 2000 Bentley Systems, Incorporated

Steel Deck Headers - H



© 2000 Bentley Systems, Incorporated

Steel Deck Headers - H



© 2000 Bentley Systems, Incorporated

Steel Deck Headers



© 2000 Bentley Systems, Incorporated

lock-switch

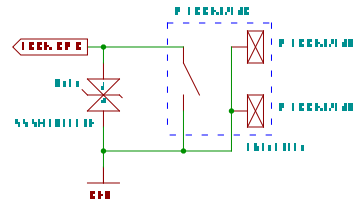

on-off

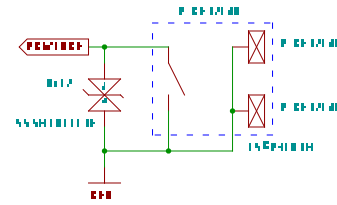

volume

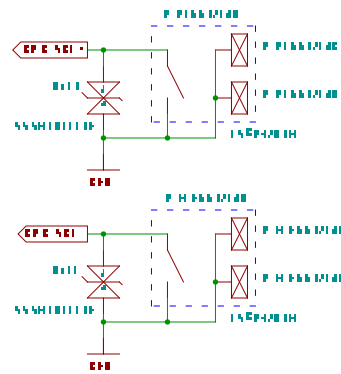

common trigger

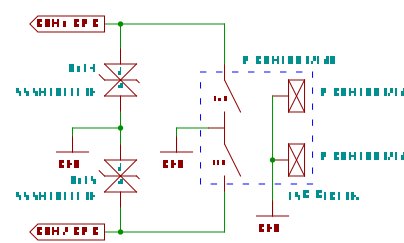

place in each wire 1-8 wire to UPPER board into all of it  
 i.e. 1 01-4 or 1 01-5 can be connected to GP10-4  
 or 10-5 to 10-6 to be in the keyboard wires  
 in any case its sufficient to connect GP10-1 01-4 and 1 01-5 to two pins on the 8 pin connector

can be used to back-terminate the motion through the DTG ports to UPPER PCB:

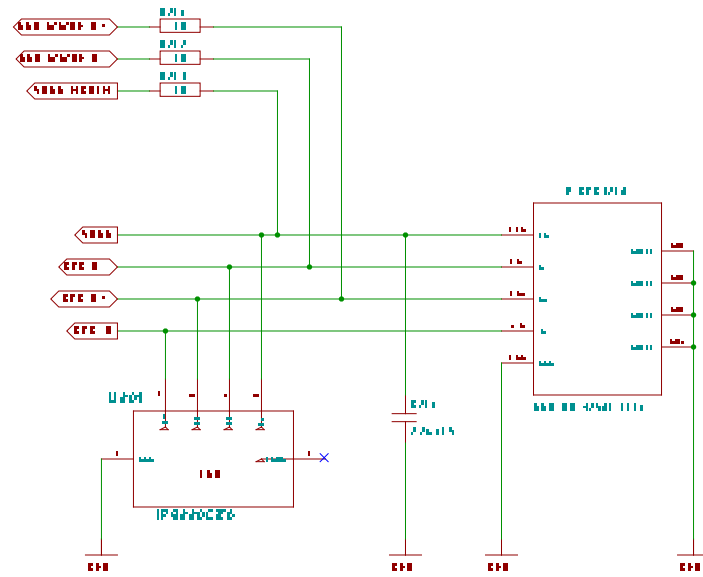

TODO

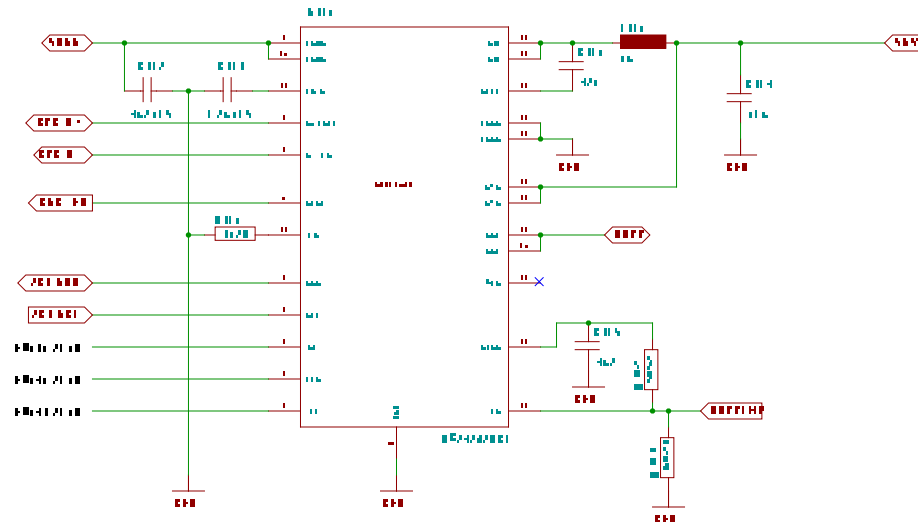

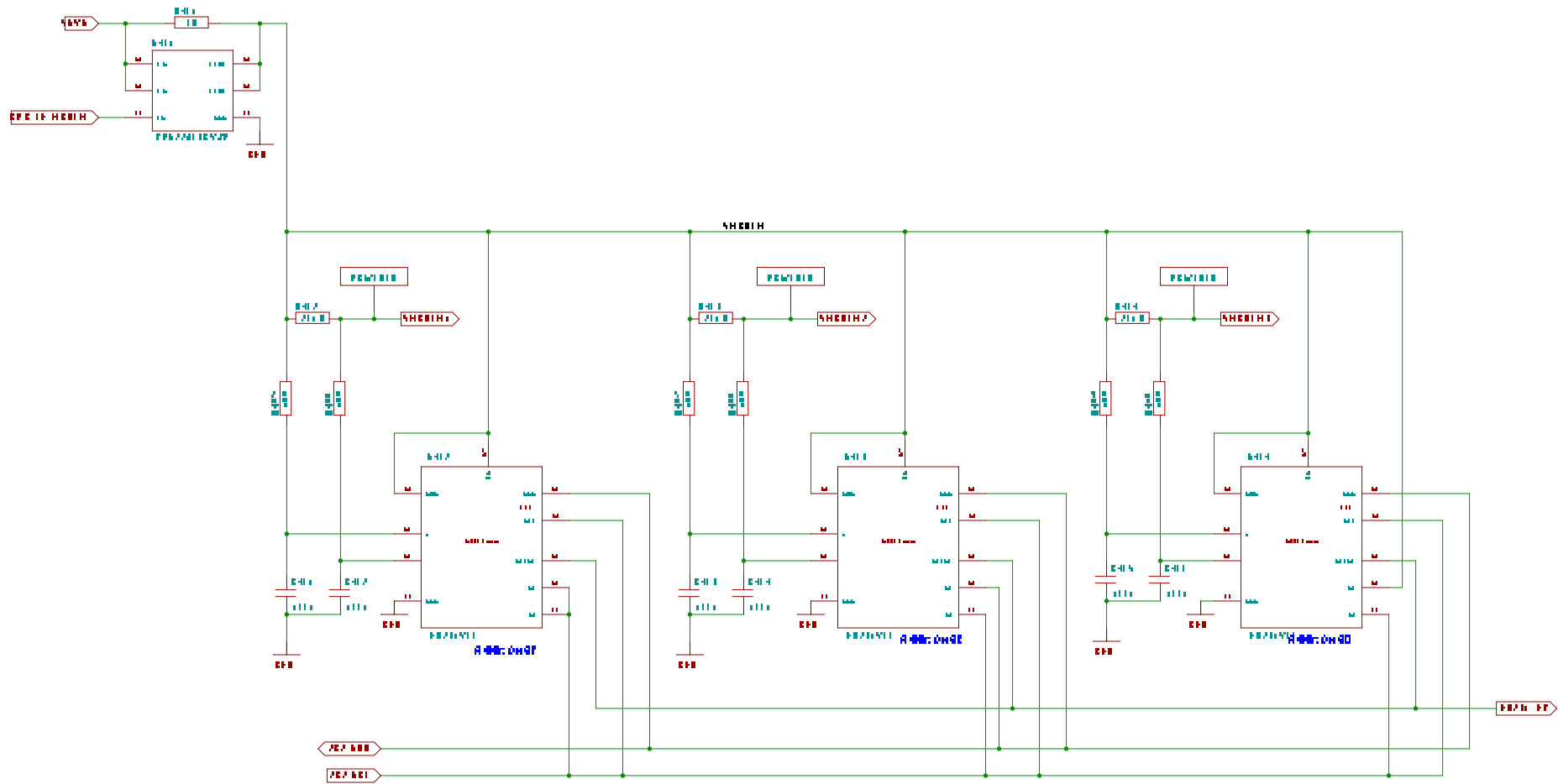

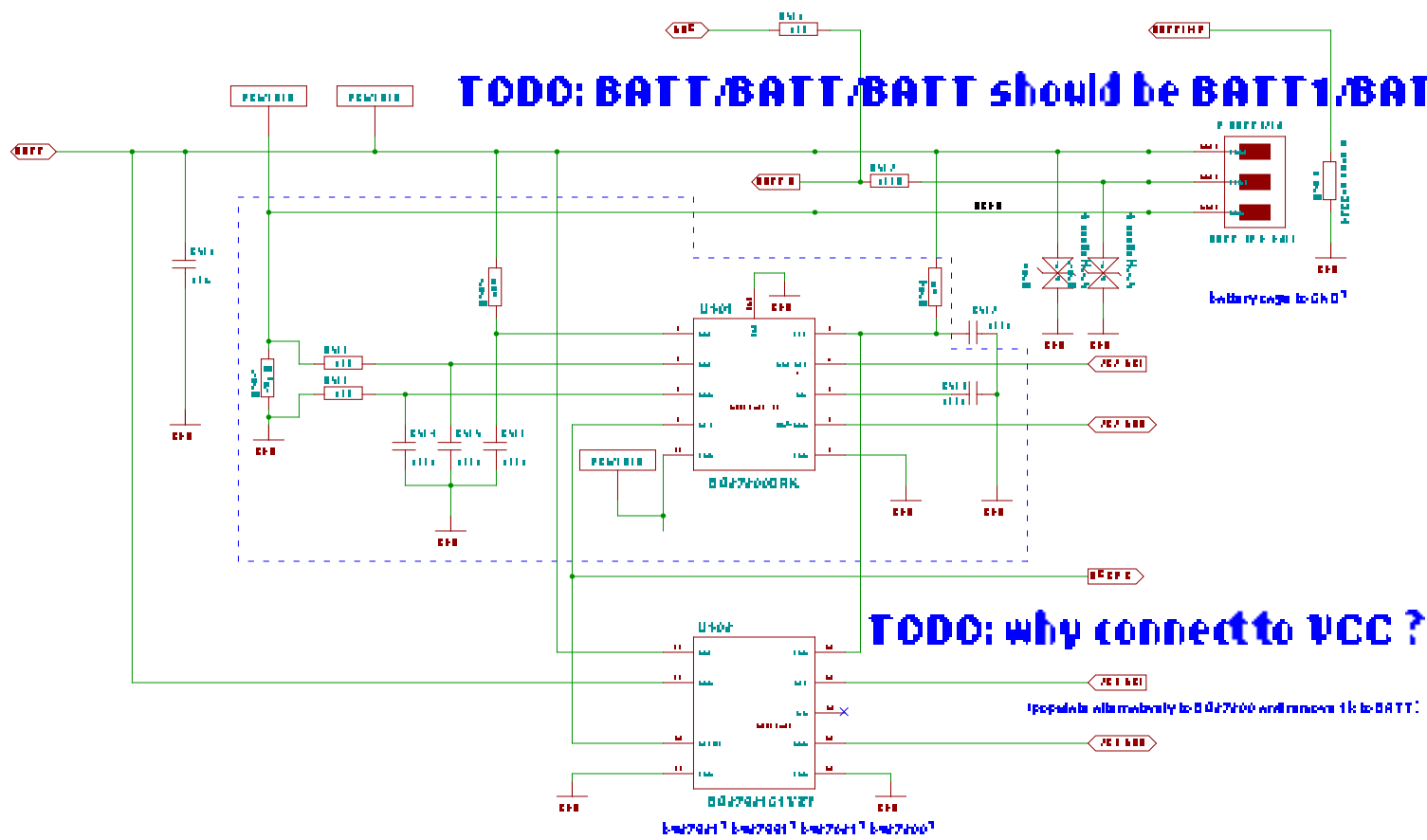

**TODO: BATT/BATT/BATT should be BATT1/BATT2/BATT3**

**TODO: why connect to VCC ?**

*(populate with polarity to BQ27421 and remove 1k to BATT)*

- TODO: U502 BAT and SRX short**
- TODO: can U501 and U502 coexist ?**
- TODO: BQ27421VZFR-G1A or B ?**



# TODO: not cleaned up - needs total rewrite

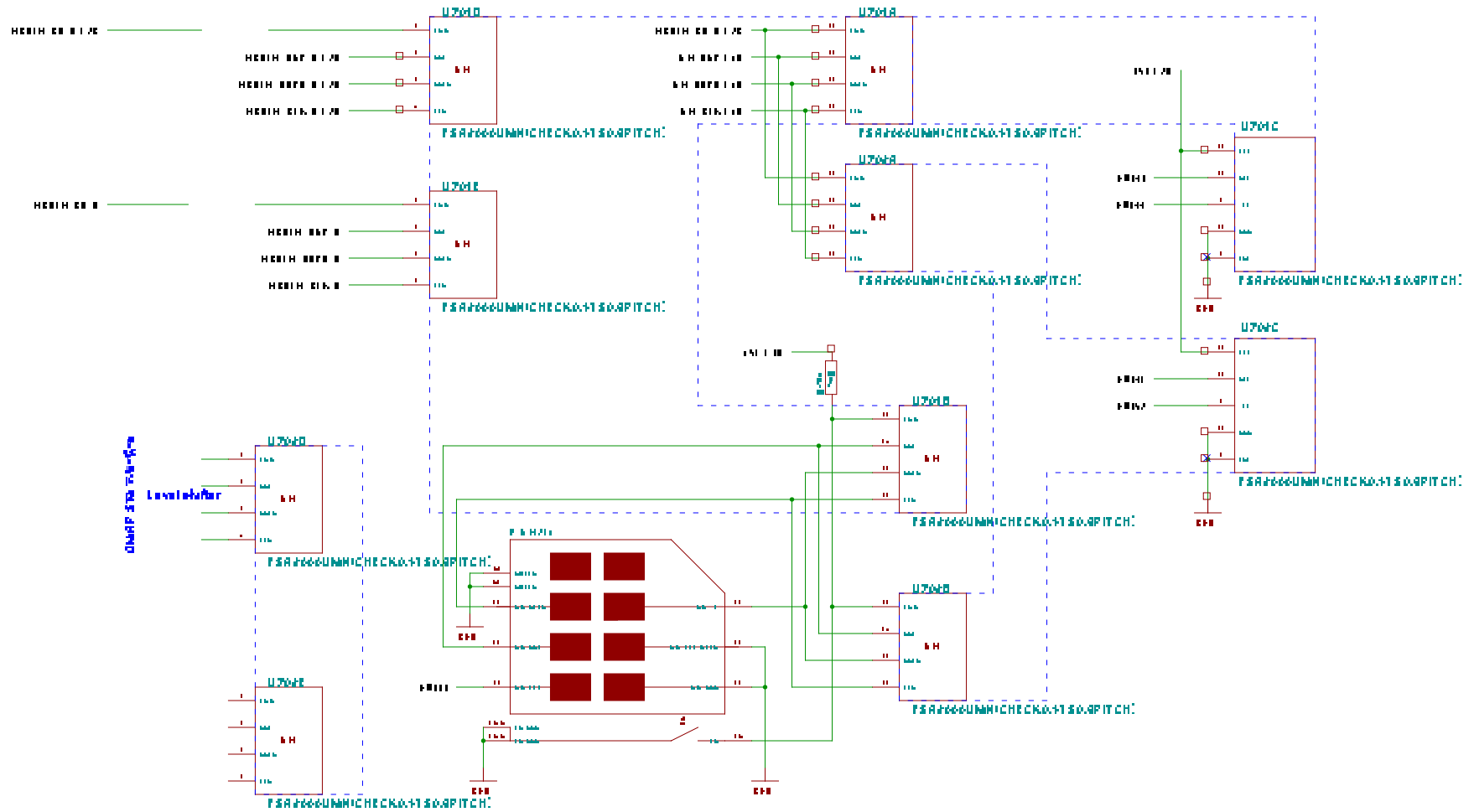

NOTE: nmos control missing  
 NOTE: CD logic missing  
 NOTE: sink power supply missing



**TODO: fix VGSS logic**

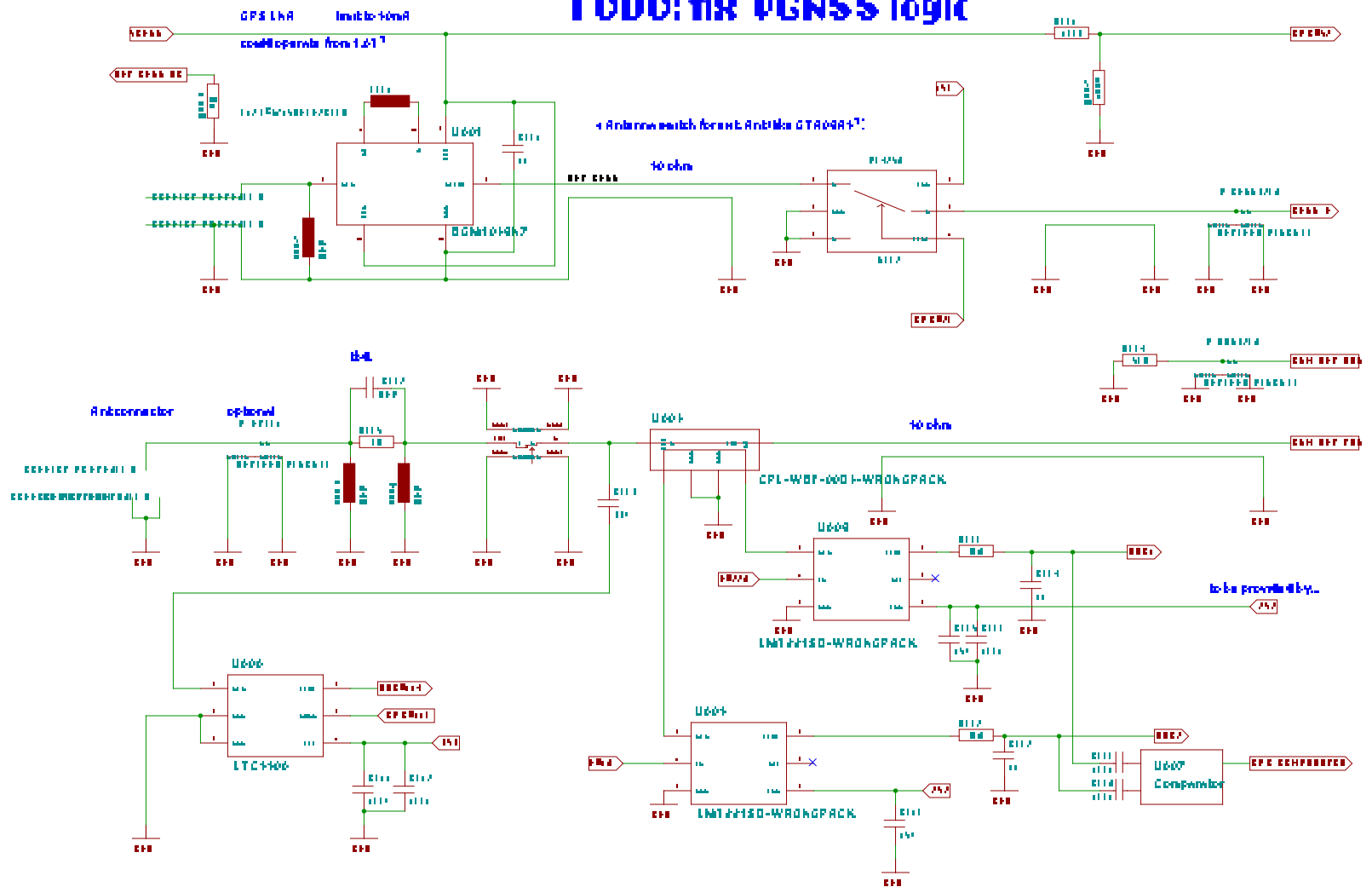

**TODO: name all the '\$\***

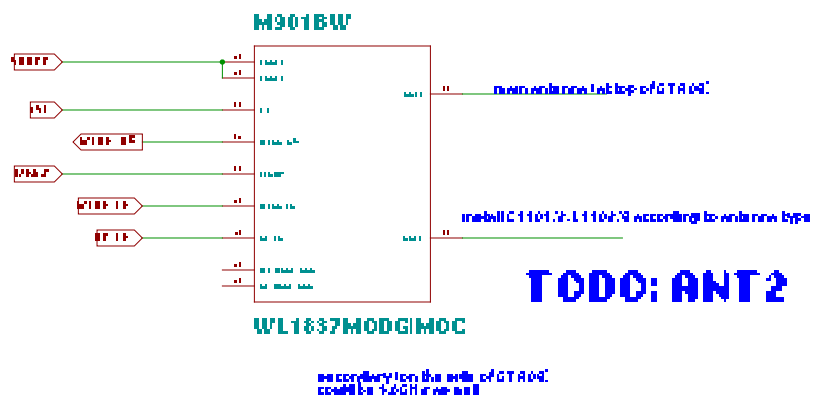

**TODO: ANT 2**

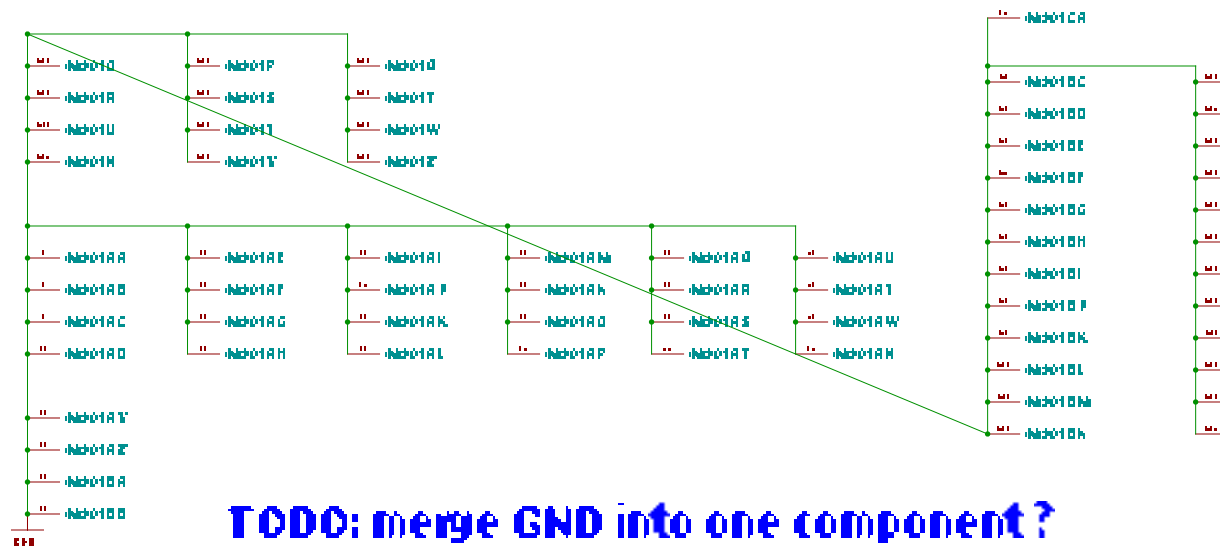

**TODO: merge GND into one component?**

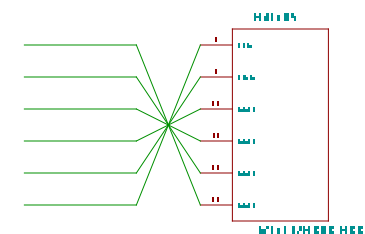
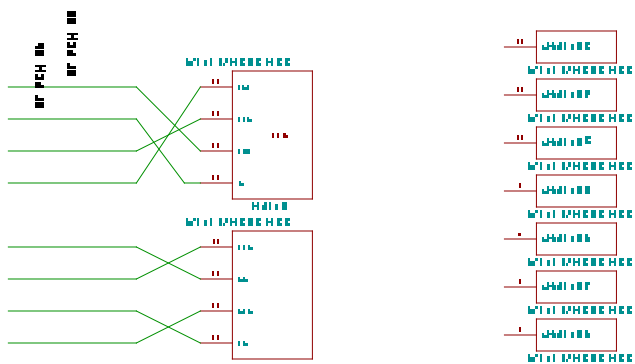

- \_\_\_\_\_ MPCB 08
- \_\_\_\_\_ MPCB 16
- \_\_\_\_\_ MPCB 18
- \_\_\_\_\_
- \_\_\_\_\_ MPCB 24
- \_\_\_\_\_ MPCB 26

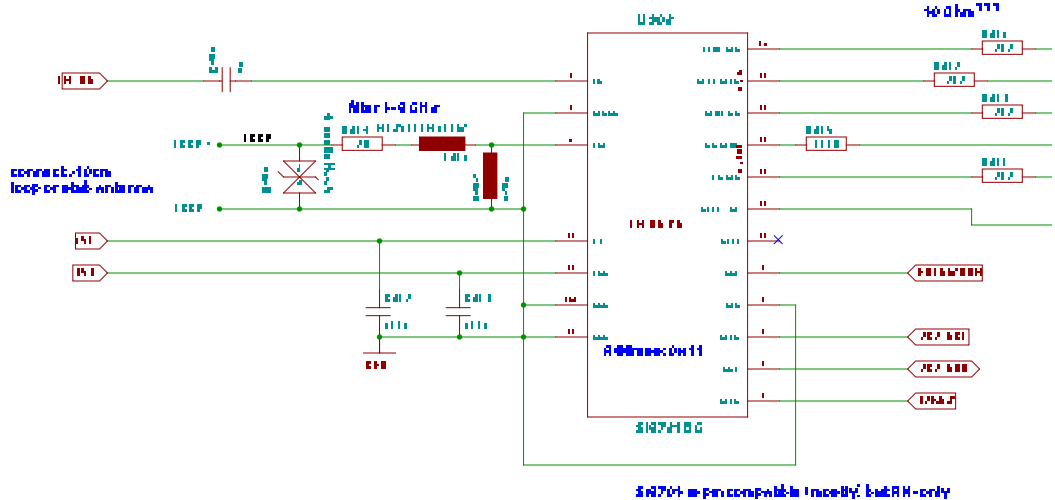

SA704 is pin compatible trace-by-trace with SA700

**TODO: merge GND**

FS  
CL  
DH  
DR  
FS  
CL

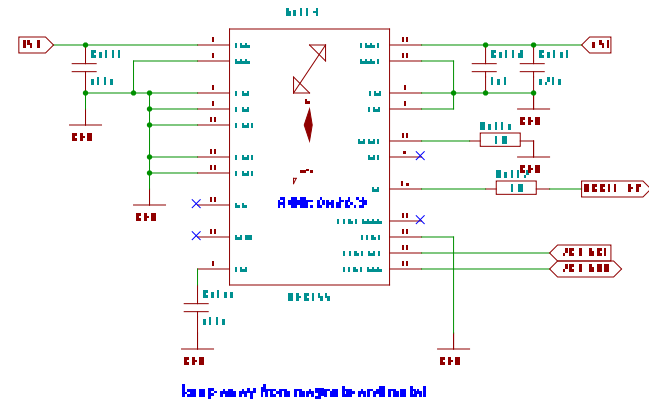
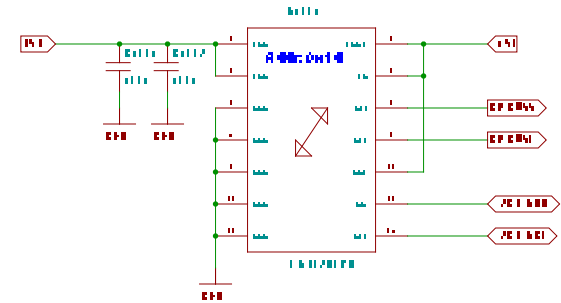
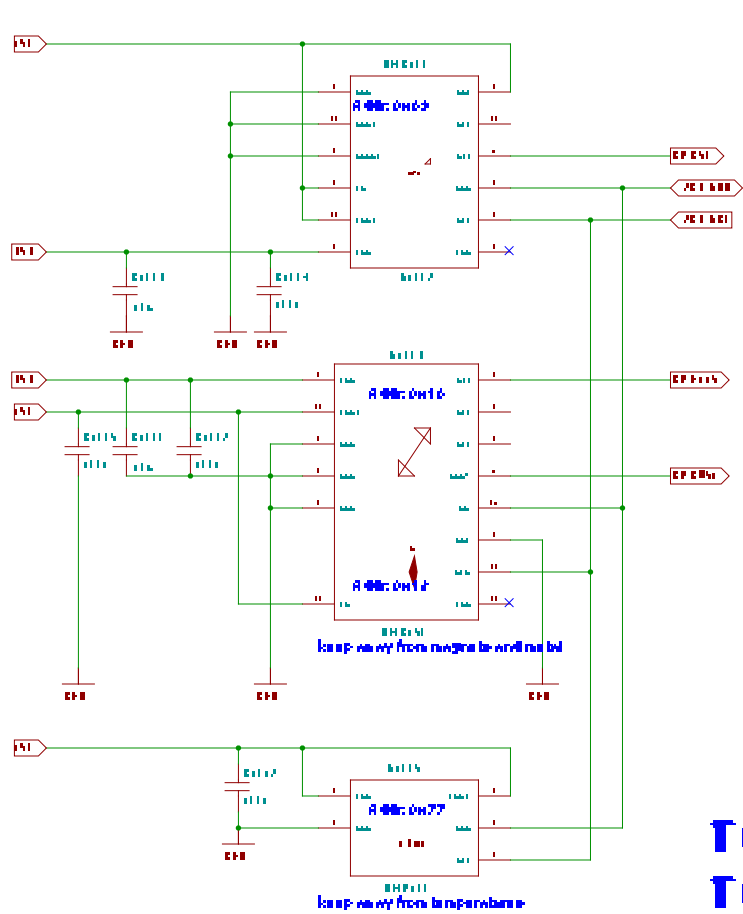

- TODO: no BMG160, BMC150**
- TODO: BMP180 -> BME280**
- TODO: BNO055 -> BMX055**
- TODO: INT1/2 sharing**

problem: the new 0.1mm BGA making board board expensive +  
 but it appears to be not a primary critical to only 1 row and inner ring = GND  
 problem: analog noise on upper board +  
 alternative: place on upper board to be evaluated

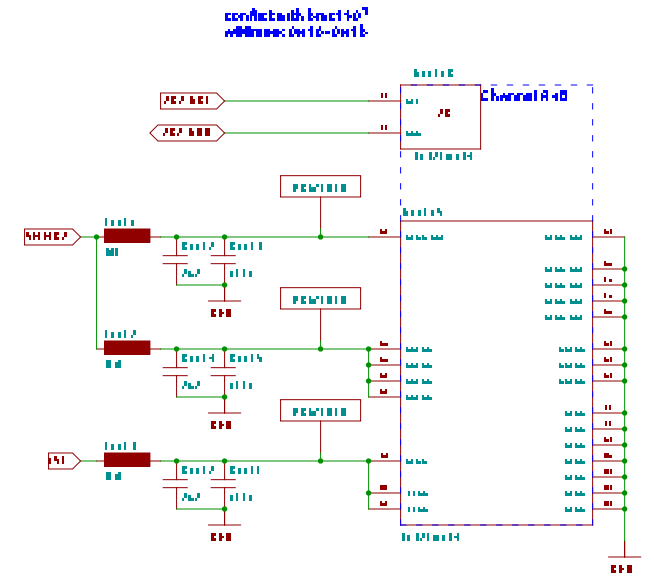
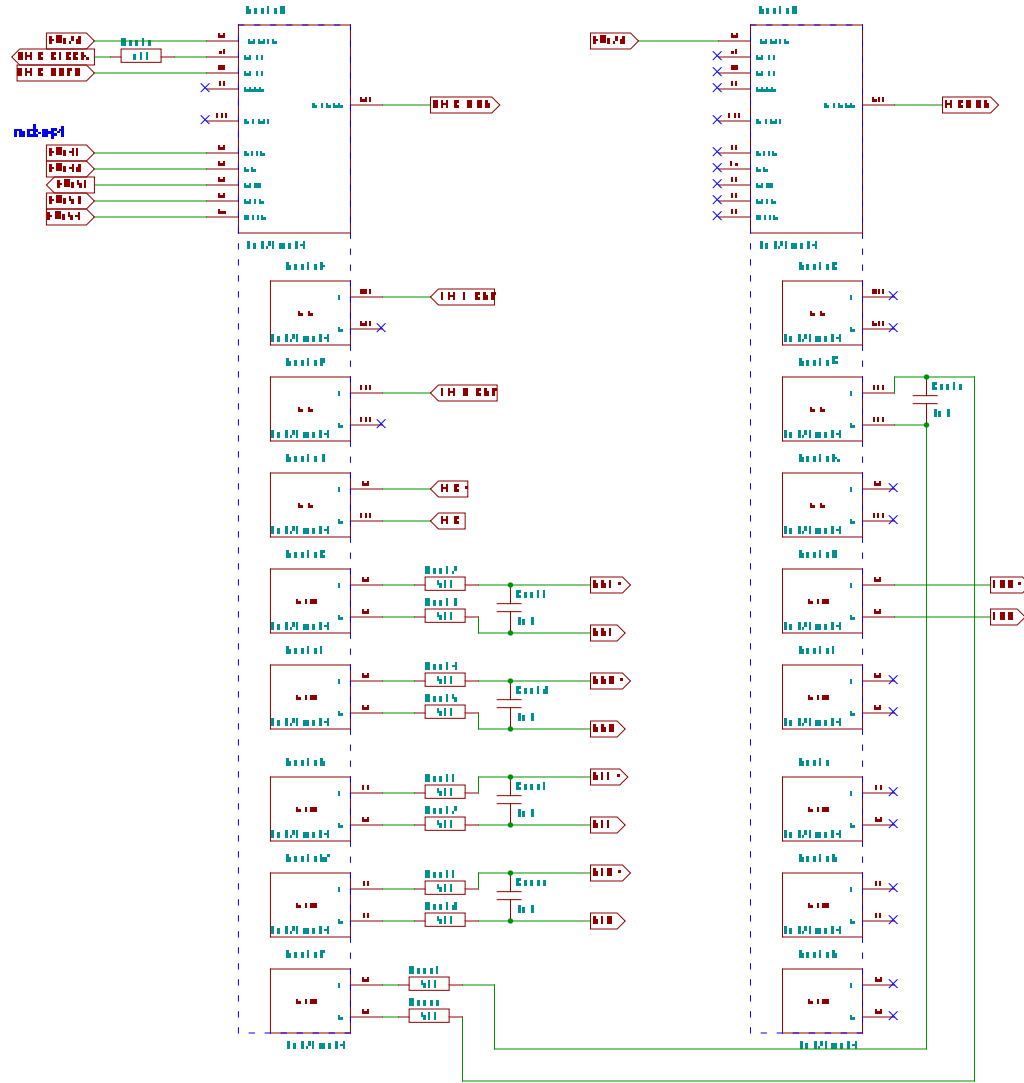

conflict with board top?  
 will have to do - do it

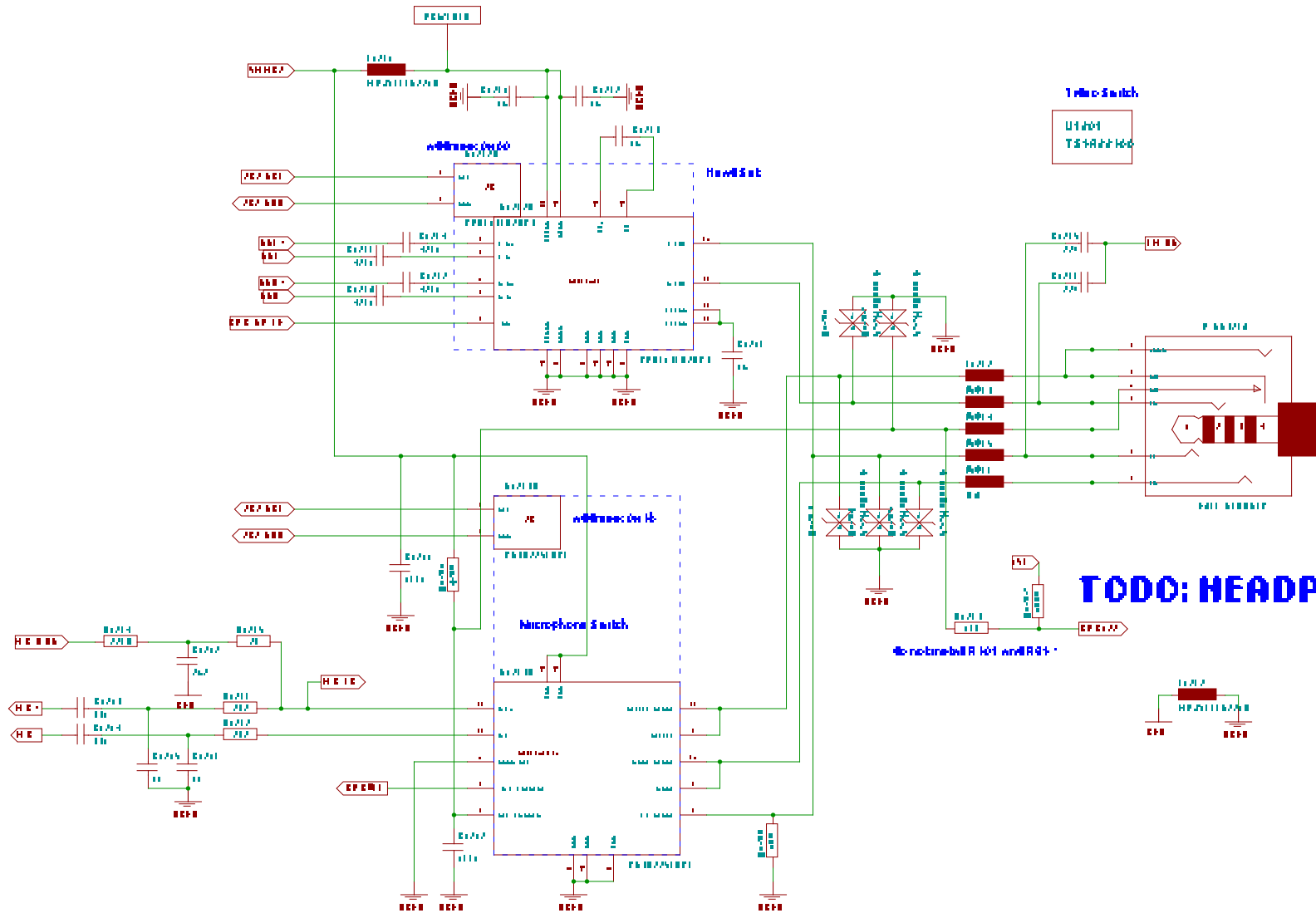

**TODO: HEADPH\_IND ?**

↳ notreiller 101 and 102

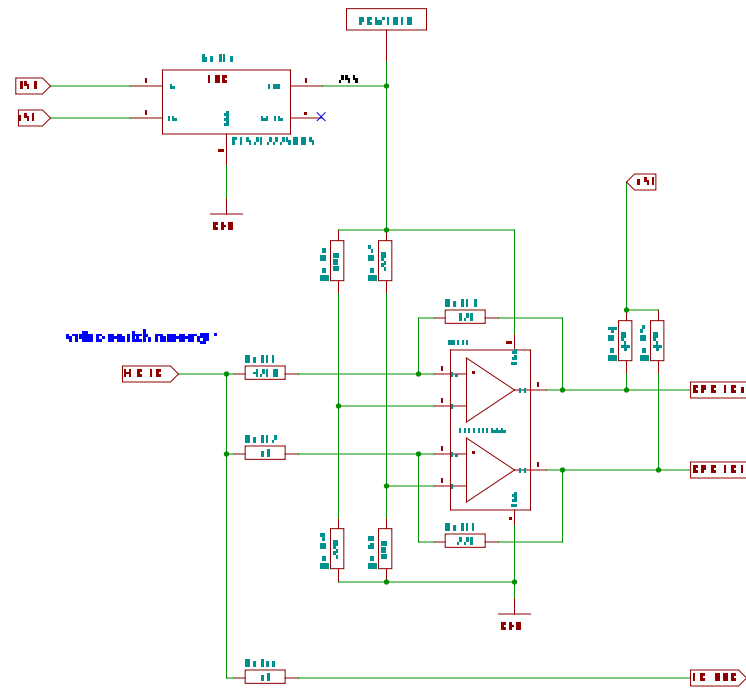

video switch missing

**TODO: draw comparator right**

Hardware Frame

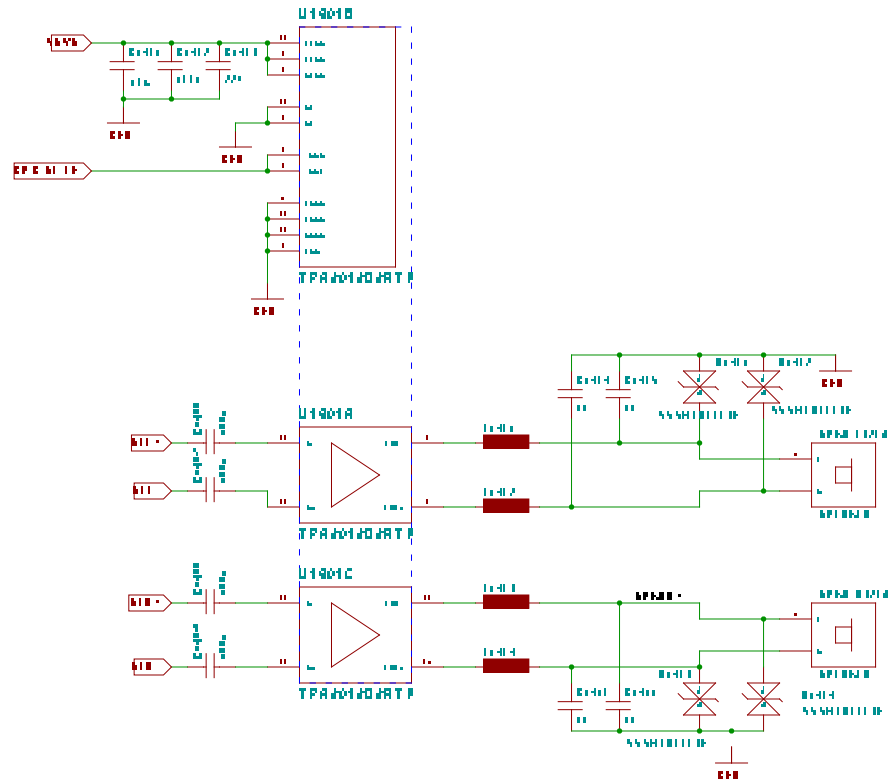

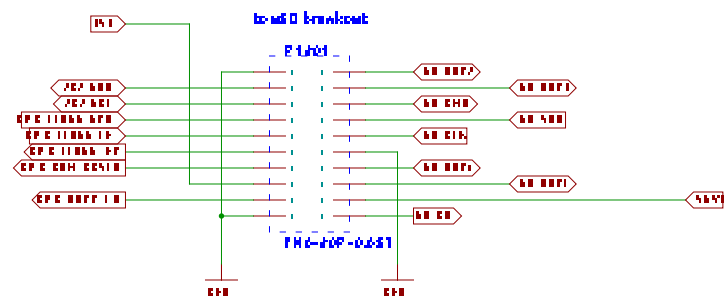

**TODO: bogus connector (see HB WP)**

**1 to 2 connector**

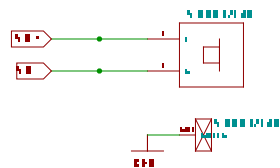

**3 to 0**

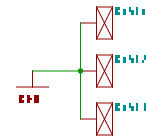



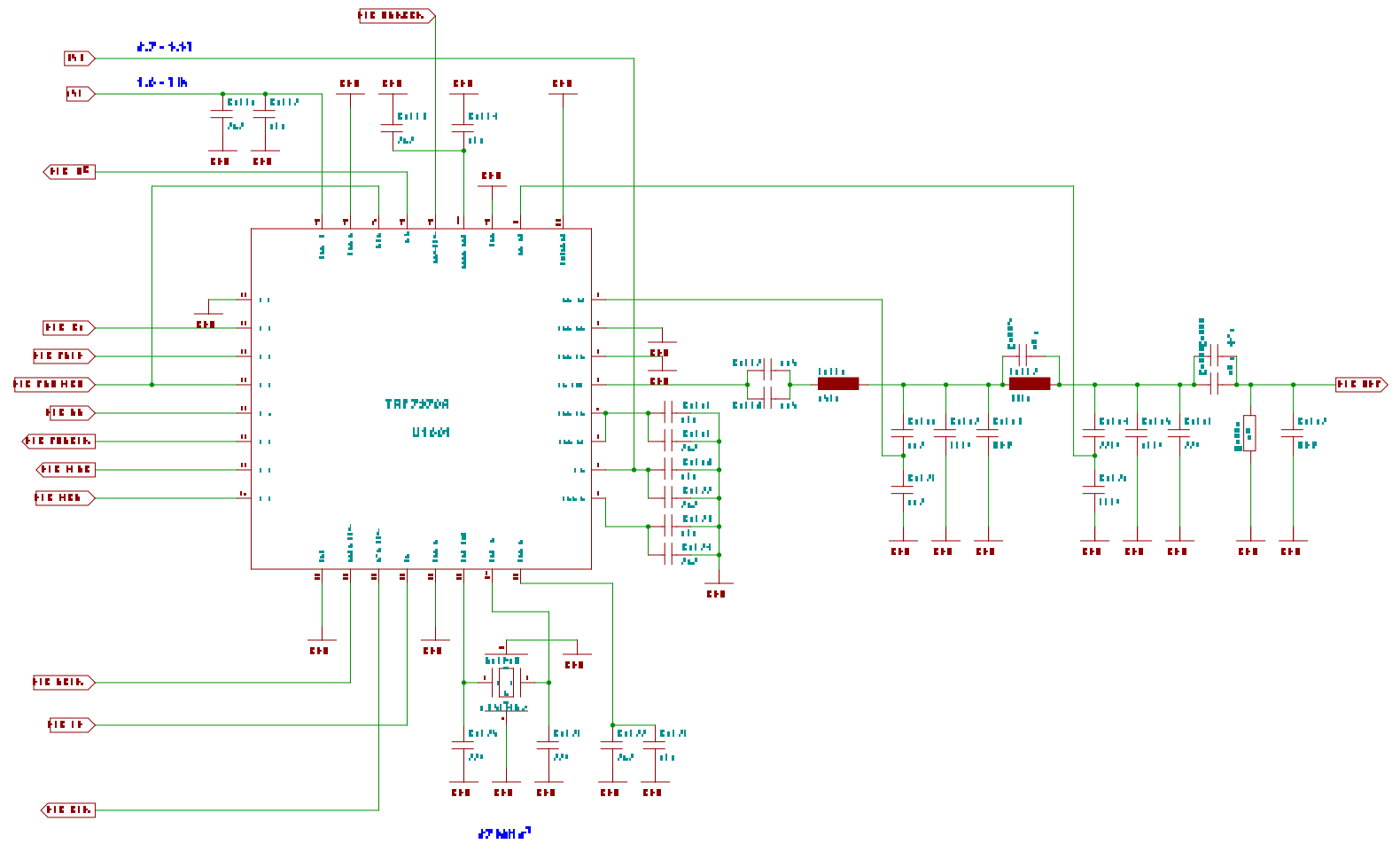



NOTE: this is wrong! eg. Blynkbot will be right! connections  
 3 pins may have to be tied through the break-out board connector more wiring assistance

**TODO: align with HB WP**

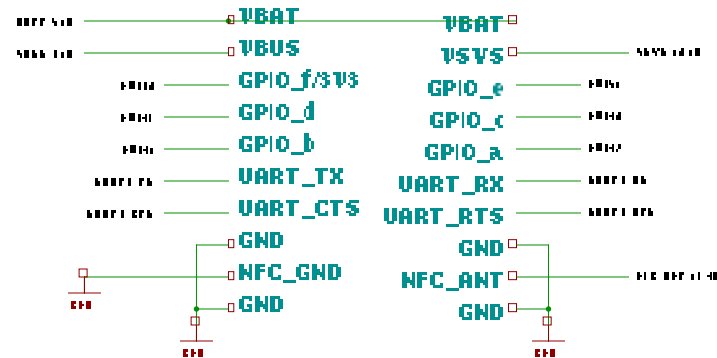
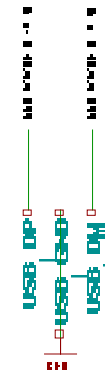

Missing 10 level shifter chip for I2C as really have the space for I2C @ pins T4R40 on 1x1mm each?

Missing 6 pin I2R for alternate function select? @ as have the space for on 1x1mm trans?

**TODO: align with HB WP**

NOTE: 116-nvylk "wala rony"

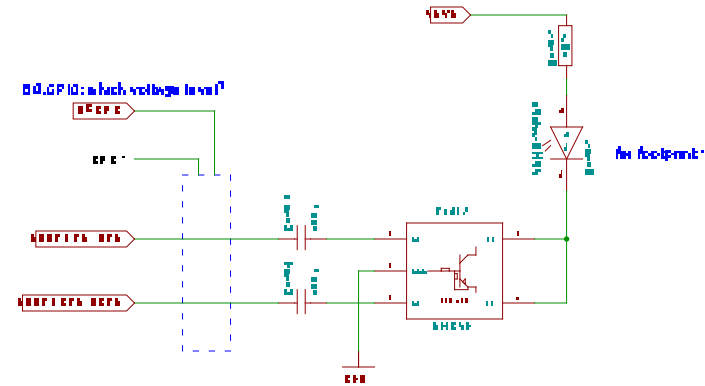
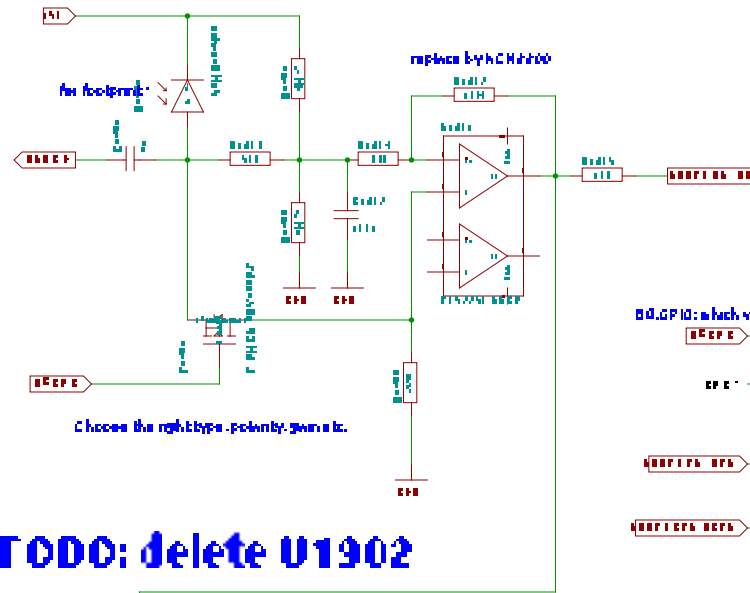

**TODO: delete U1902**

**TODO: update to design in IR WP**

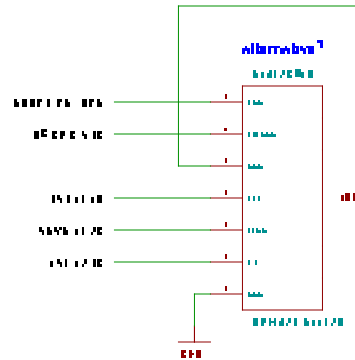





# TODO: track B2B to UPPER

=====  
=====  
=====

to be with a 40 to lower board connector

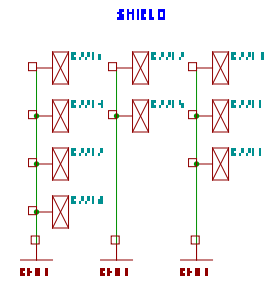
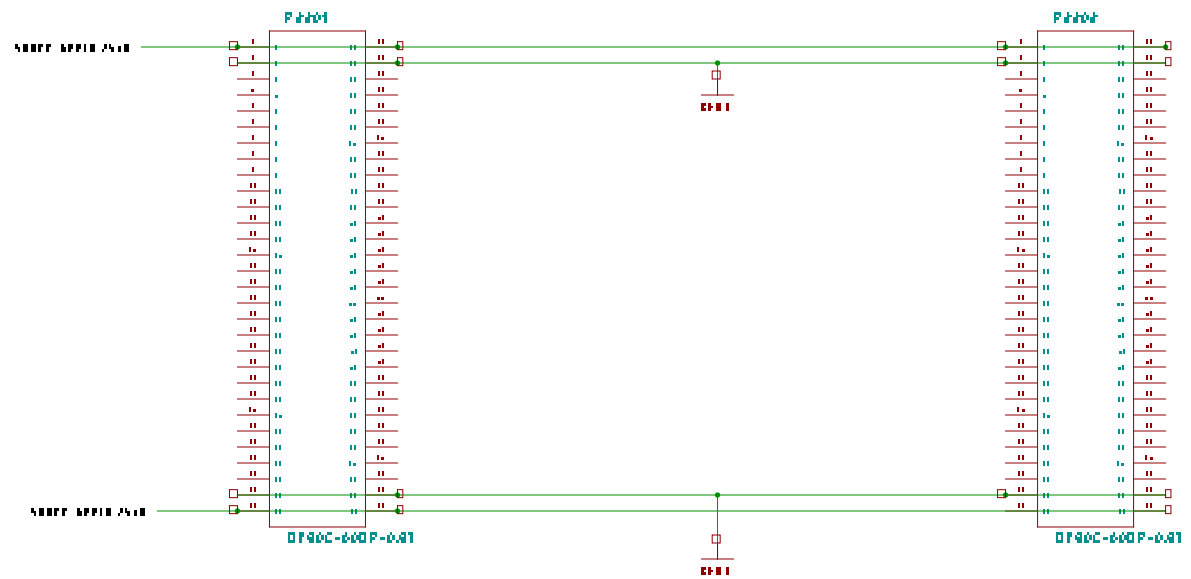

# TODO: \*\_UPPER names ?

name the final bearing to each button on which position?  
TOL+ and TOL- could drive PETA settings in the matrix

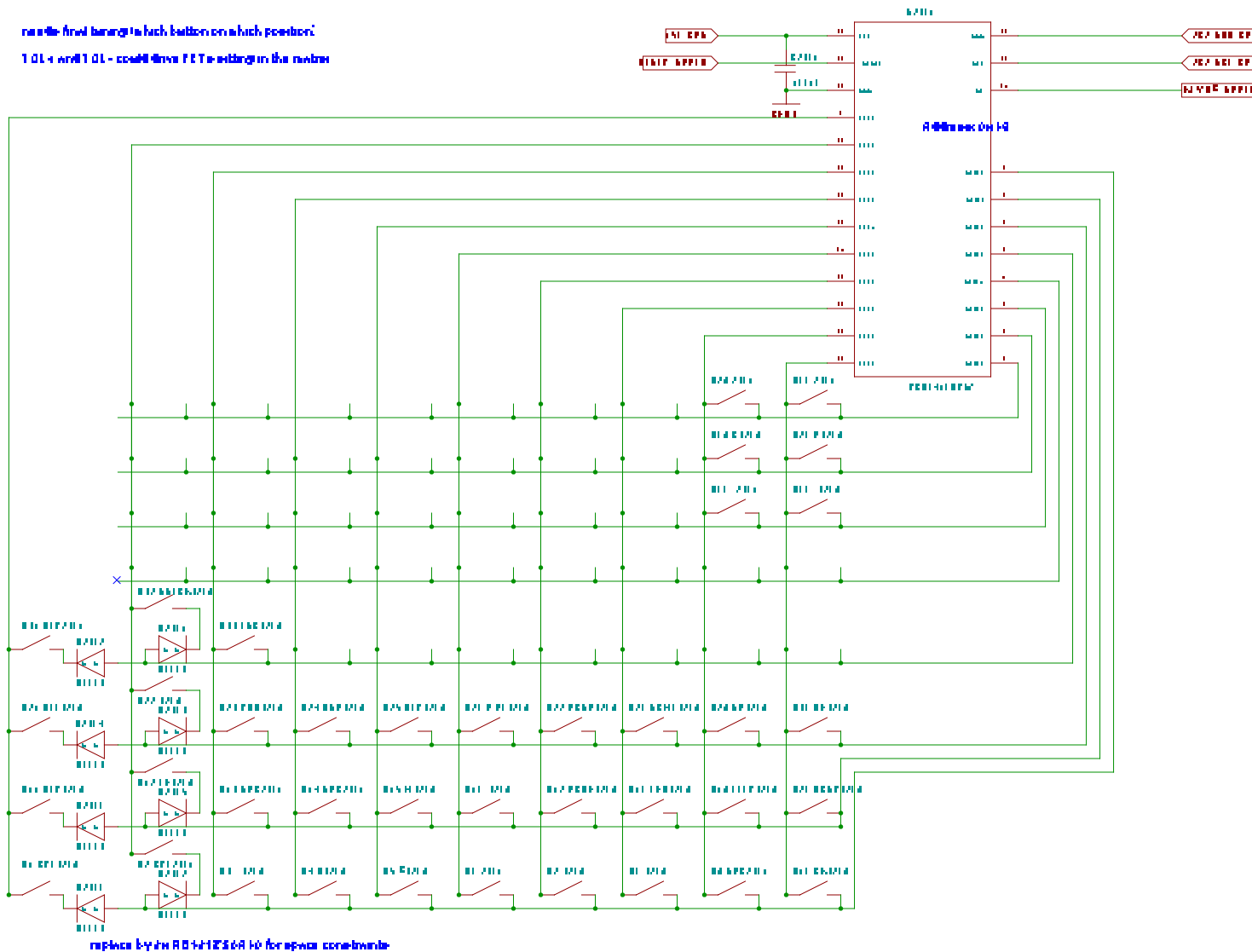

TODO: remove \$709 in comp ref

TODO: remove keycap from comp ref

TODO: sort out 6 "ext" buttons

TODO: rearrange matrix to avoid diodes ?







INCOMPLETE int

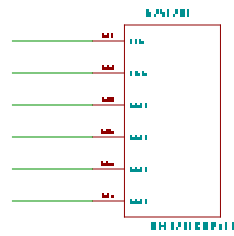
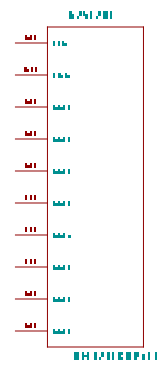
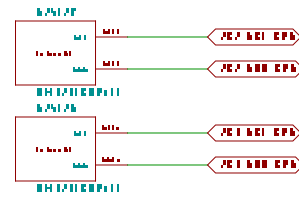
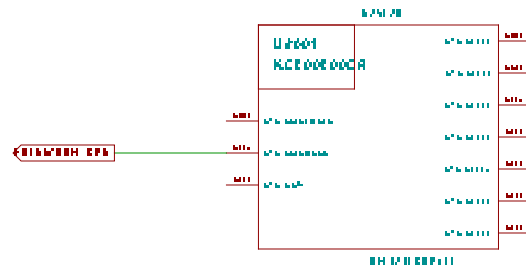

INCOMPLETE INT

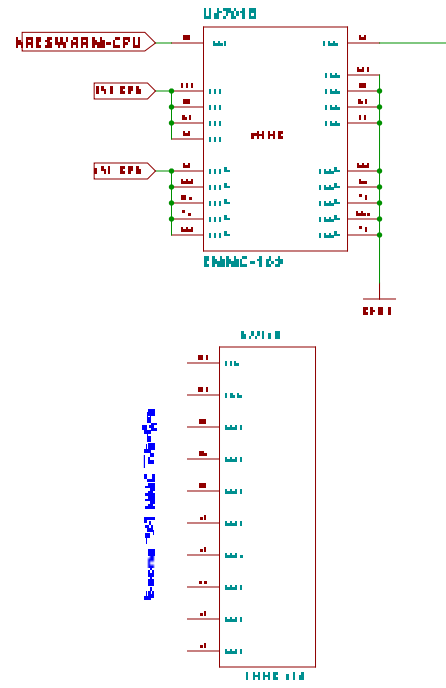

# TODO: check role

INCOMPLETE in 17

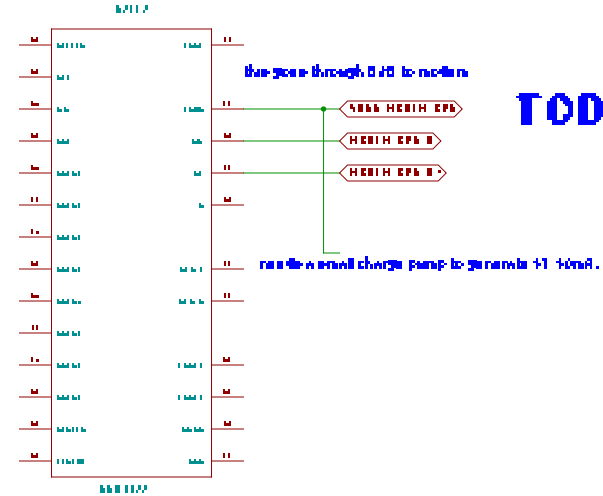
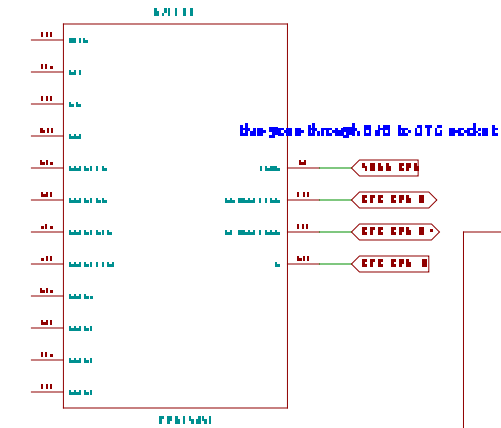
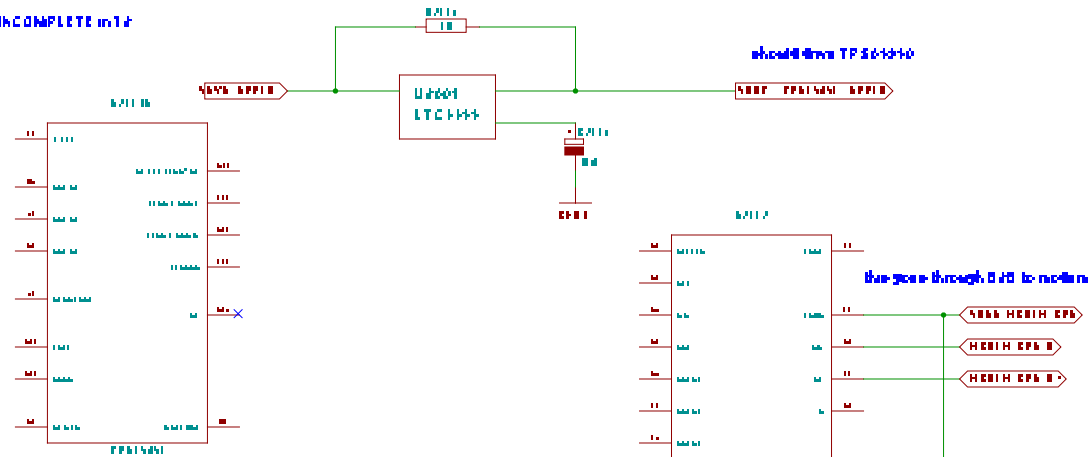

# TODO: VBUS-MODEM ?

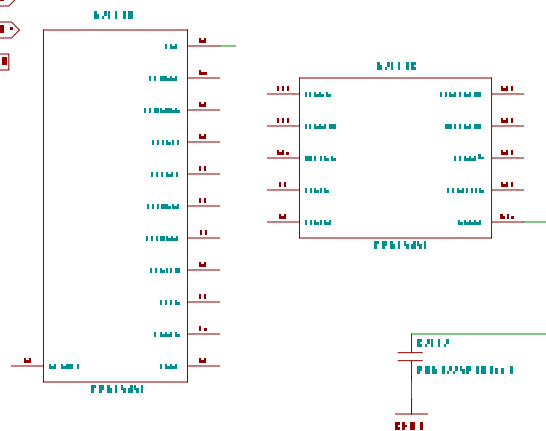

sample capture 900ms LDO for TP30340 evaluation  
only for prototype.

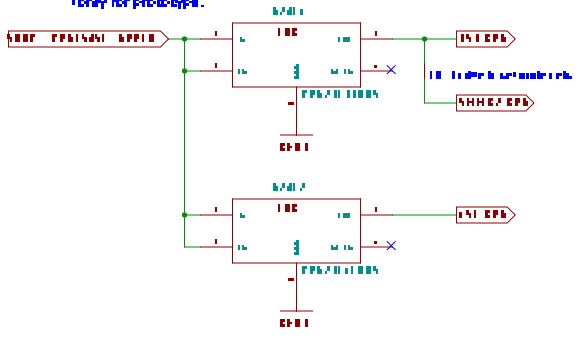

INCOMPLETE int

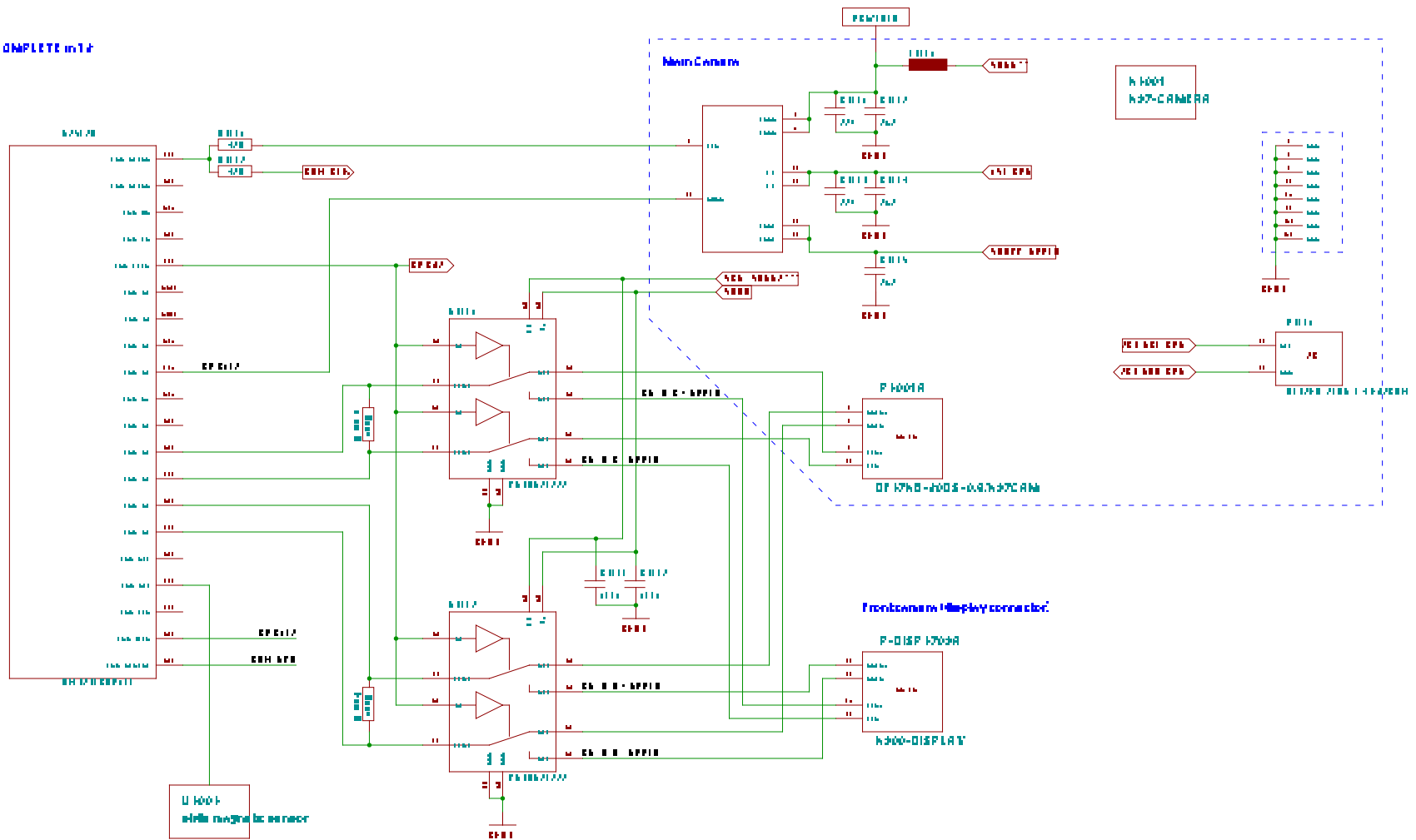

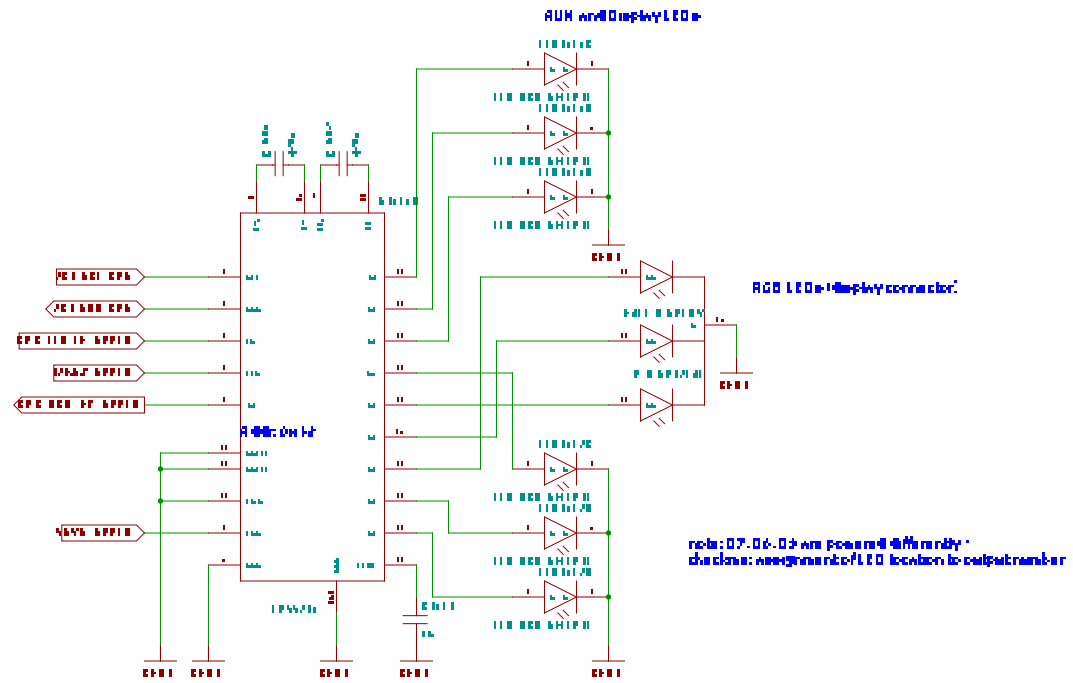



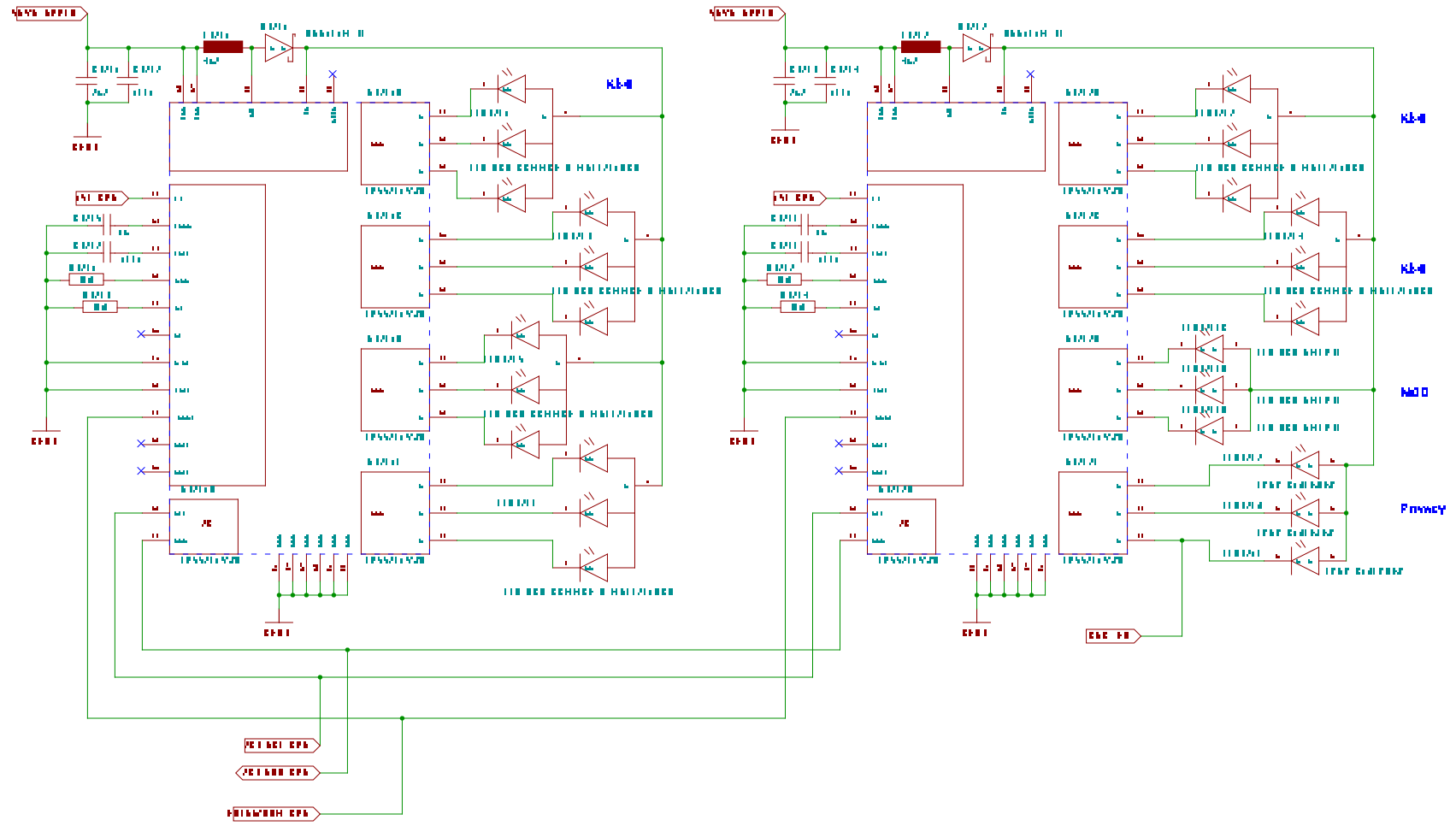

These connections allow to "simulate" the DM1710 by connecting a DB-HM

INCOMPLETE  
prototype only

Connects DM1710 MUXSP™, PC2-MIMIC\* - to some CP10\*

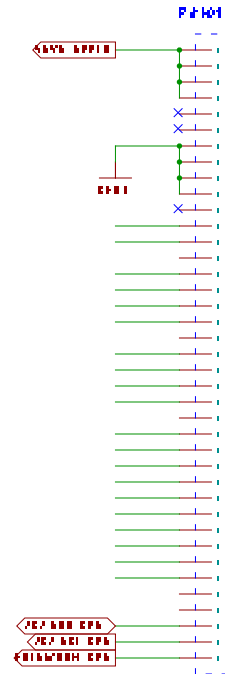

connect to respective CPU-swills

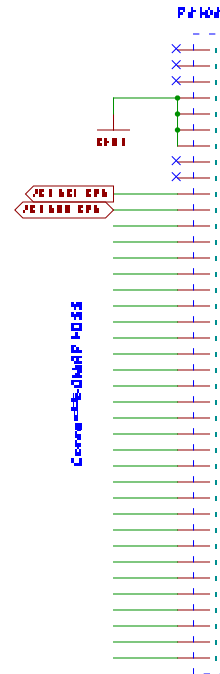

DBS - CP10 - PC1

Connects DM1710 PC1 to PC2

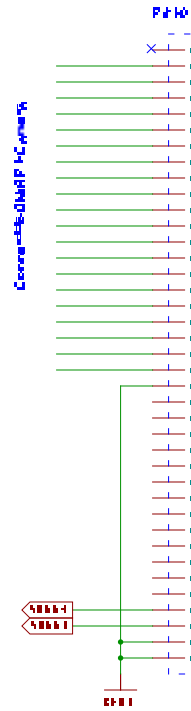

connect to DB  
by using Micro-USB cable

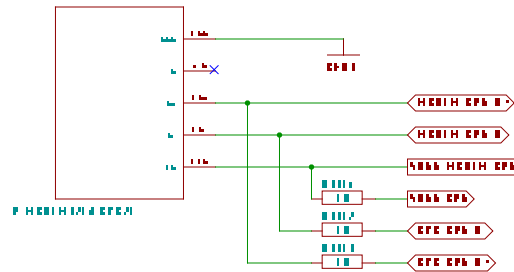

**TODO: VBUS-MODEM ?**

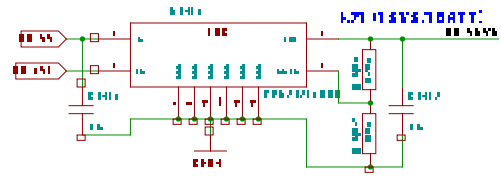

5V L7805C 5V back converter

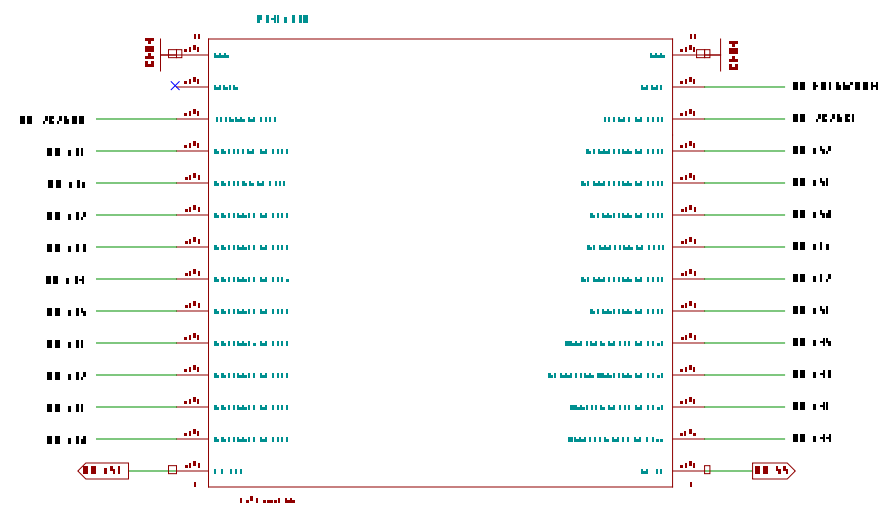
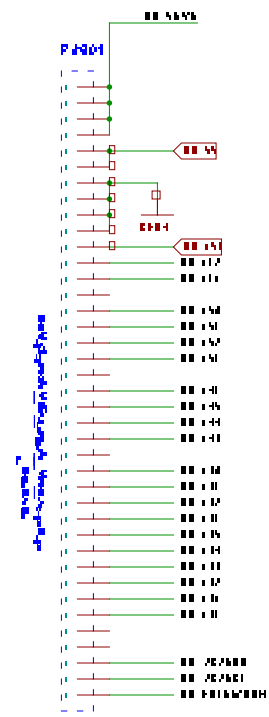

5V L7805C 5V back converter

**TODO:** needs decision on where to take this

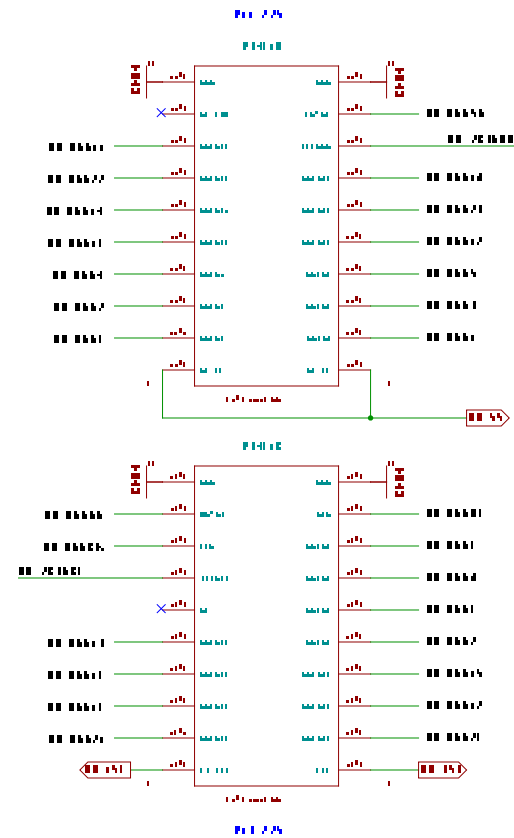
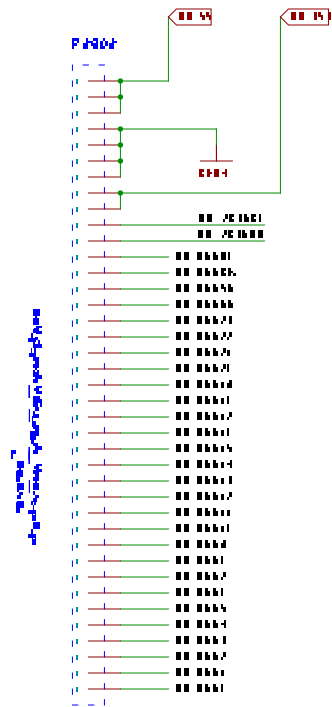

**TODO: needs decision on where to take this**



Note: Jump cable to connect BB-HM-A Register to Upper board

