

Click | Here

This sheet: index

Sheet: OTG
File: neo900_SS_2.sch
OTG & Switches

Sheet: Charger/OTG-Booster
File: neo900_SS_3.sch
Charger/OTG-Booster

Sheet: Modem Power
File: neo900_SS_4.sch
Modem Power

Sheet: Fuel Gauge
File: neo900_SS_5.sch
Fuel Gauge

Sheet: 3G/4G Modem + SIM
File: neo900_SS_6.sch
3G/4G Modem + SIM

Sheet: Dual SIM switch
File: neo900_SS_7.sch
Dual SIM switch

Sheet: Antenna connections
File: neo900_SS_8.sch
Antenna connections

Sheet: WLAN, Bluetooth, FM
File: neo900_SS_9.sch
WLAN, Bluetooth, FM

Sheet: Sensors
File: neo900_SS_10.sch
Sensors

Sheet: Audio Codec
File: neo900_SS_11.sch
Audio Codec

Sheet: Audio Headset + Mic
File: neo900_SS_12.sch
Audio Headset + Mic

Sheet: ECI
File: neo900_SS_13.sch
ECI

Sheet: Audio Handsfree
File: neo900_SS_14.sch
Audio Handsfree

Sheet: Misc (lower)
File: neo900_SS_15.sch
Misc (lower)

Sheet: RFID/NFC Reader
File: neo900_SS_16.sch
RFID/NFC Reader

Sheet: RFID/NFC Controller
File: neo900_SS_17.sch
RFID/NFC Controller

Sheet: Hackerbus
File: neo900_SS_18.sch
Hackerbus

Sheet: Infrared
File: neo900_SS_19.sch
Infrared

Sheet: B2B to UPPER
File: neo900_SS_20.sch
B2B to UPPER

Sheet: uSD Breakout Board
File: neo900_SS_21.sch
uSD Breakout Board

Sheet: B2B to LOWER
File: neo900_SS_22.sch
B2B to LOWER

Sheet: Keypad
File: neo900_SS_23.sch
Keypad

Sheet: Display-Peripherals
File: neo900_SS_24.sch
Display-Peripherals

Sheet: Display-Panel&Power
File: neo900_SS_25.sch
Display-Panel&Power

Click | Here

Sheet: CPU + PoP RAM/NAND
File: neo900_SS_26.sch
CPU + PoP RAM/NAND

Sheet: eMMC
File: neo900_SS_27.sch
eMMC

Sheet: PMU+Codec
File: neo900_SS_28.sch
PMU+Codec

Sheet: BB-XM Dummy (TWL4030)
File: neo900_SS_29.sch
BB-XM Dummy (TWL4030)

Sheet: Camera
File: neo900_SS_30.sch
Camera

Sheet: LEDs
File: neo900_SS_31.sch
LEDs

Sheet: Fancy LEDs
File: neo900_SS_32.sch
Fancy LEDs

Sheet: Connector to BB-XM
File: neo900_SS_33.sch
Connector to BB-XM

Sheet: BB-XM Adapter (CPU)
File: neo900_SS_34.sch
BB-XM Adapter (CPU)

Sheet: BB-XM Adapter (DISP)
File: neo900_SS_35.sch
BB-XM Adapter (DISP)

Sheet: BB-XM Adapter (CAM)
File: neo900_SS_36.sch
BB-XM Adapter (CAM)

Sheet: No-Solder Components
File: neo900_SS_37.sch
No-Solder Components

Note regarding I2C addresses:
Addresses in the schematics are provided for convenience.
The authoritative source is
<https://neo900.org/git?p=misc;a=tree;f=i2c>

| | | |
|------------------|----------|----------|
| Sheet: / | | |
| File: neo900.sch | | |
| Title: Neo900 | | |
| Size: %Z | Date: %D | Rev: %R |
| %K | | Id: 1/37 |

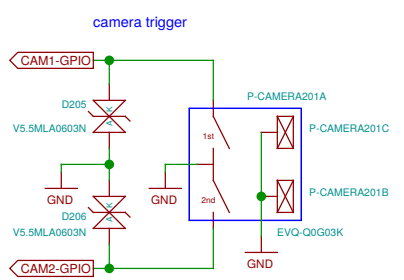
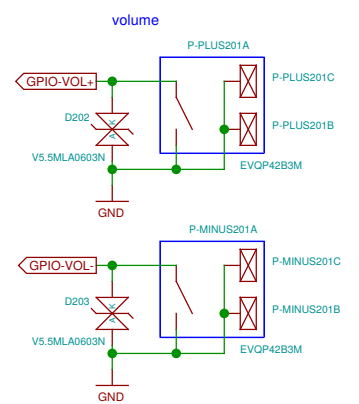
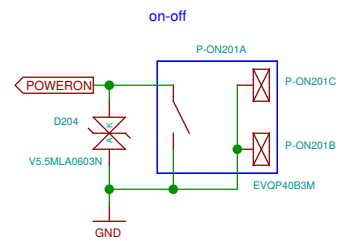
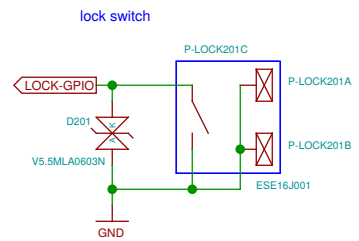

can be used to test/operate the modem through the OTG port (w/o UPPER PCB)

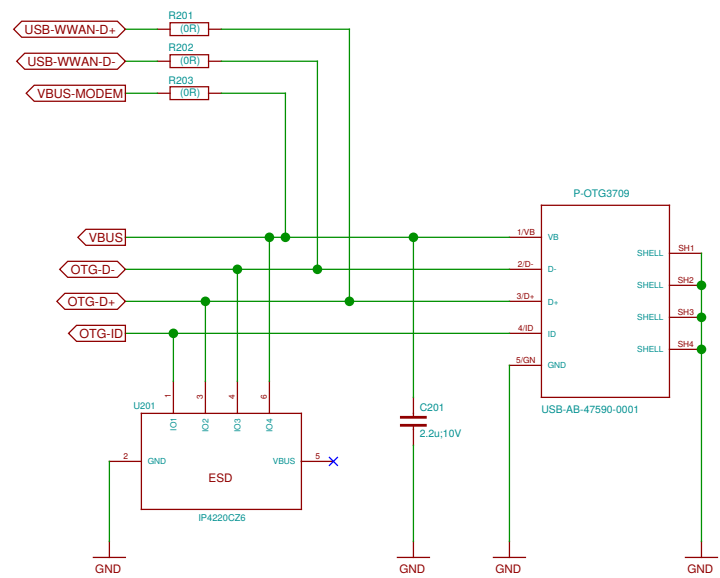

place in scan matrix? would need 3-4 wires to UPPER board instead of 2
 in any case it is sufficient to connect GPIO-VOL+ and VOL- to two pins on the B2B connector

TODO

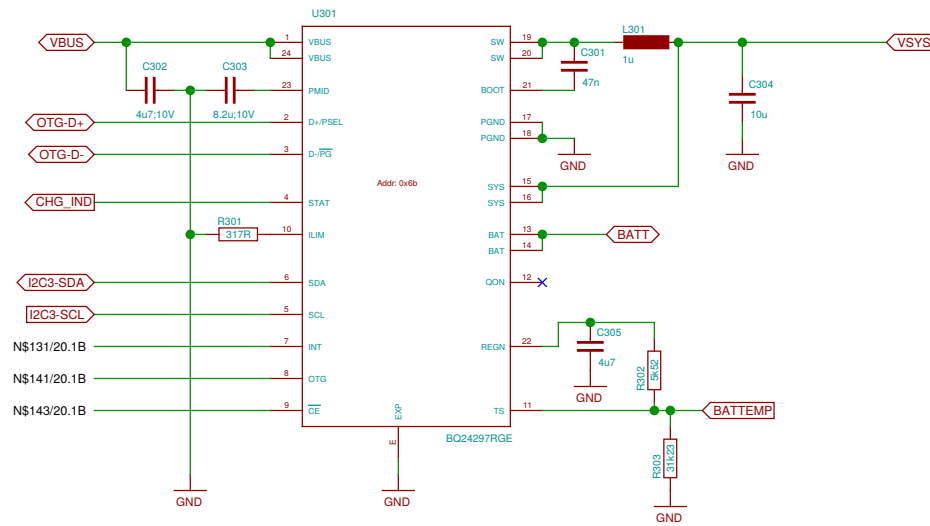

| | | |
|---|----------|----------|
| Sheet: /Charger/OTG-Booster/ File: neo900_SS_3.sch | | |
| Title: Charger/OTG-Booster | | |
| Size: %Z | Date: %D | Rev: %R |
| %K | | Id: 3/37 |

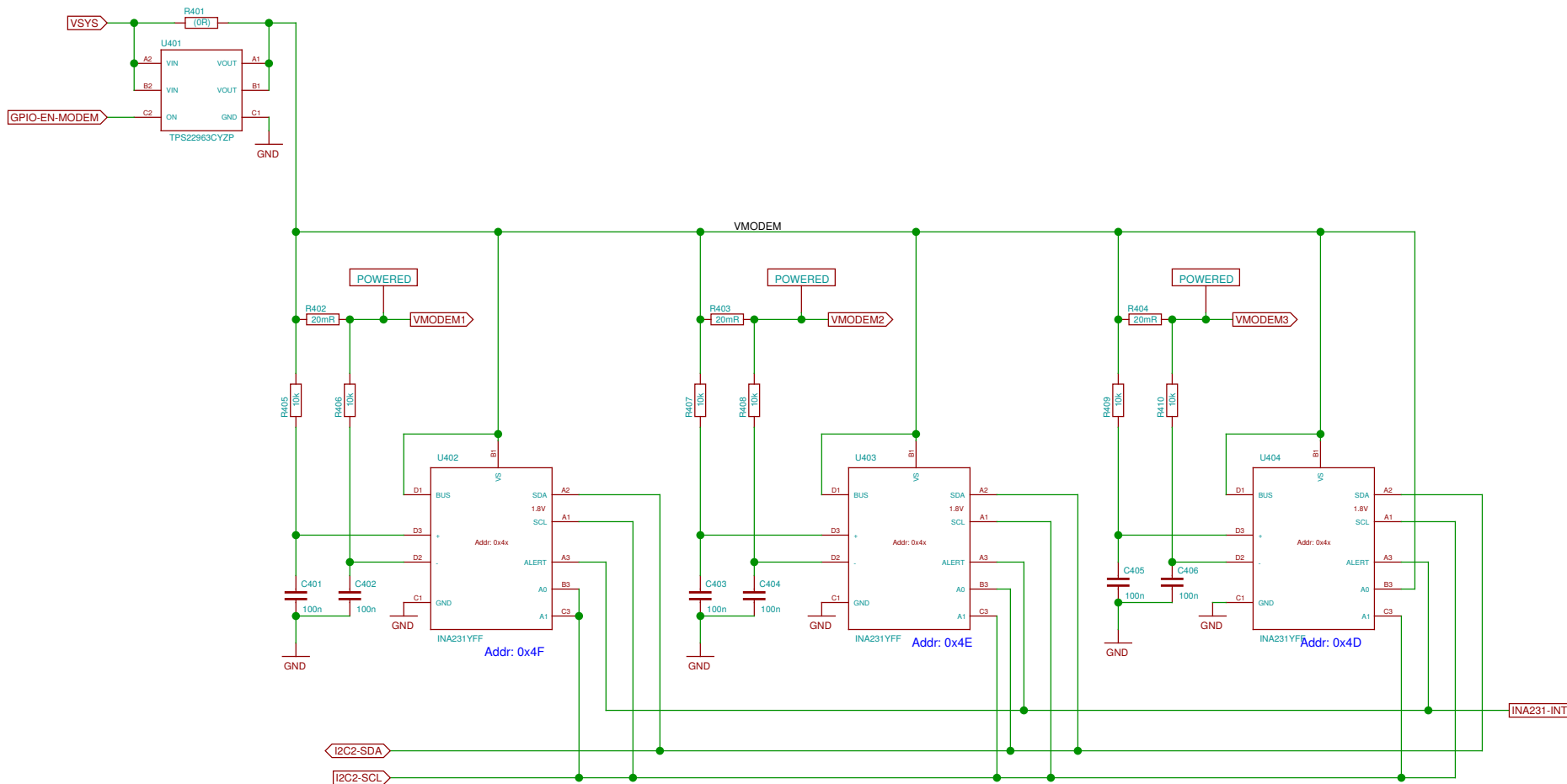

| | | | |
|----------------------|----------|-----------------------|----------|
| Sheet: /Modem Power/ | | File: neo900_SS_4.sch | |
| Title: Modem Power | | | |
| Size: %Z | Date: %D | Rev: %R | Id: 4/37 |
| %K | | | |

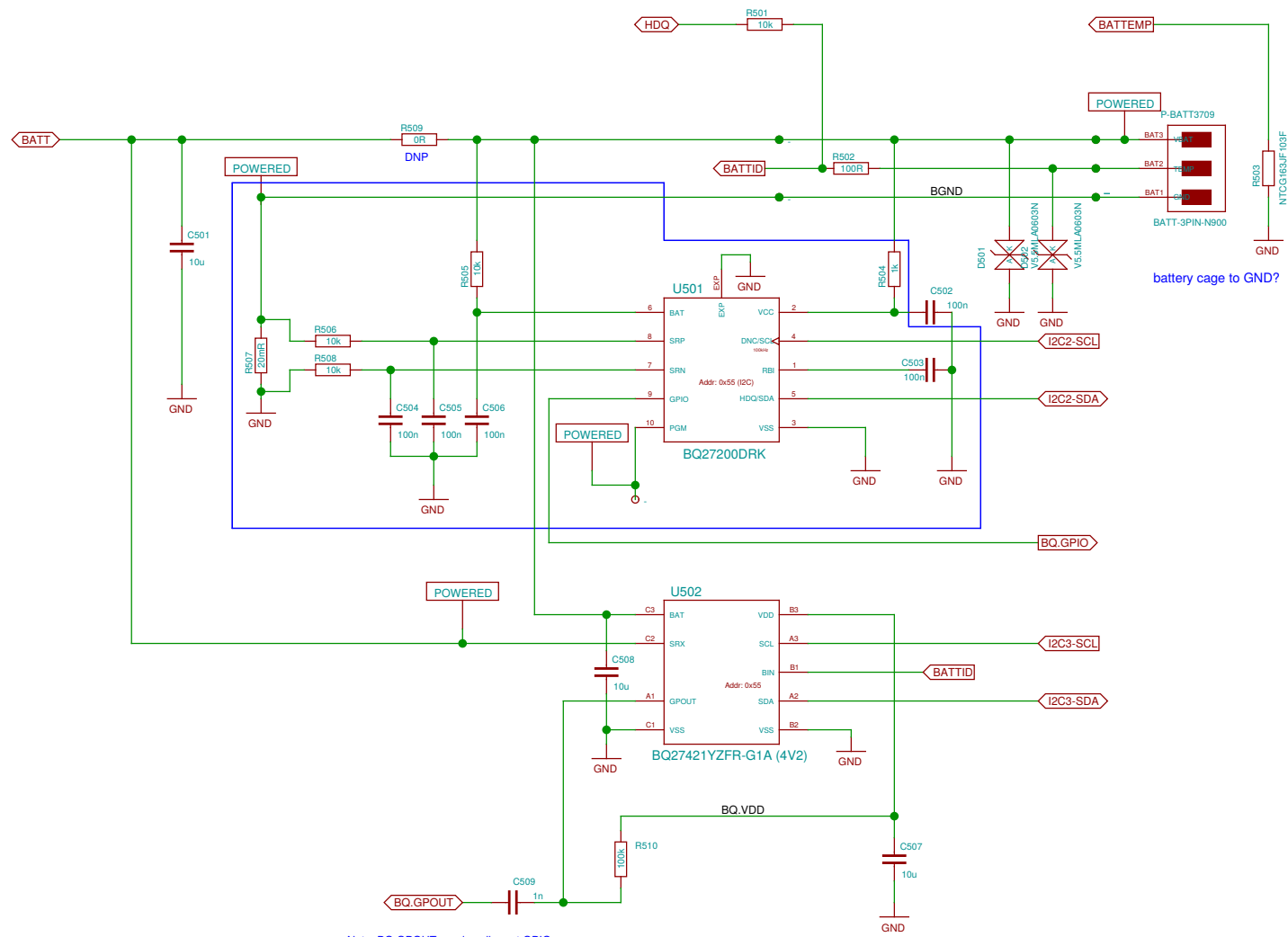

Note: BQ.GPOUT needs pull-up at GPIO.

battery cage to GND?

| | | |
|-----------------------|----------|----------|
| Sheet: /Fuel Gauge/ | | |
| File: neo900_SS_5.sch | | |
| Title: Fuel Gauge | | |
| Size: %Z | Date: %D | Rev: %R |
| %K | | Id: 5/37 |

TODO: do what simsw WP says

TODO: UART#1 ?

TODO: shield connection near D8

Can we connect UART in parallel to Bluetooth UART (i.e. if BT is disabled we can unbrick the Modem?)

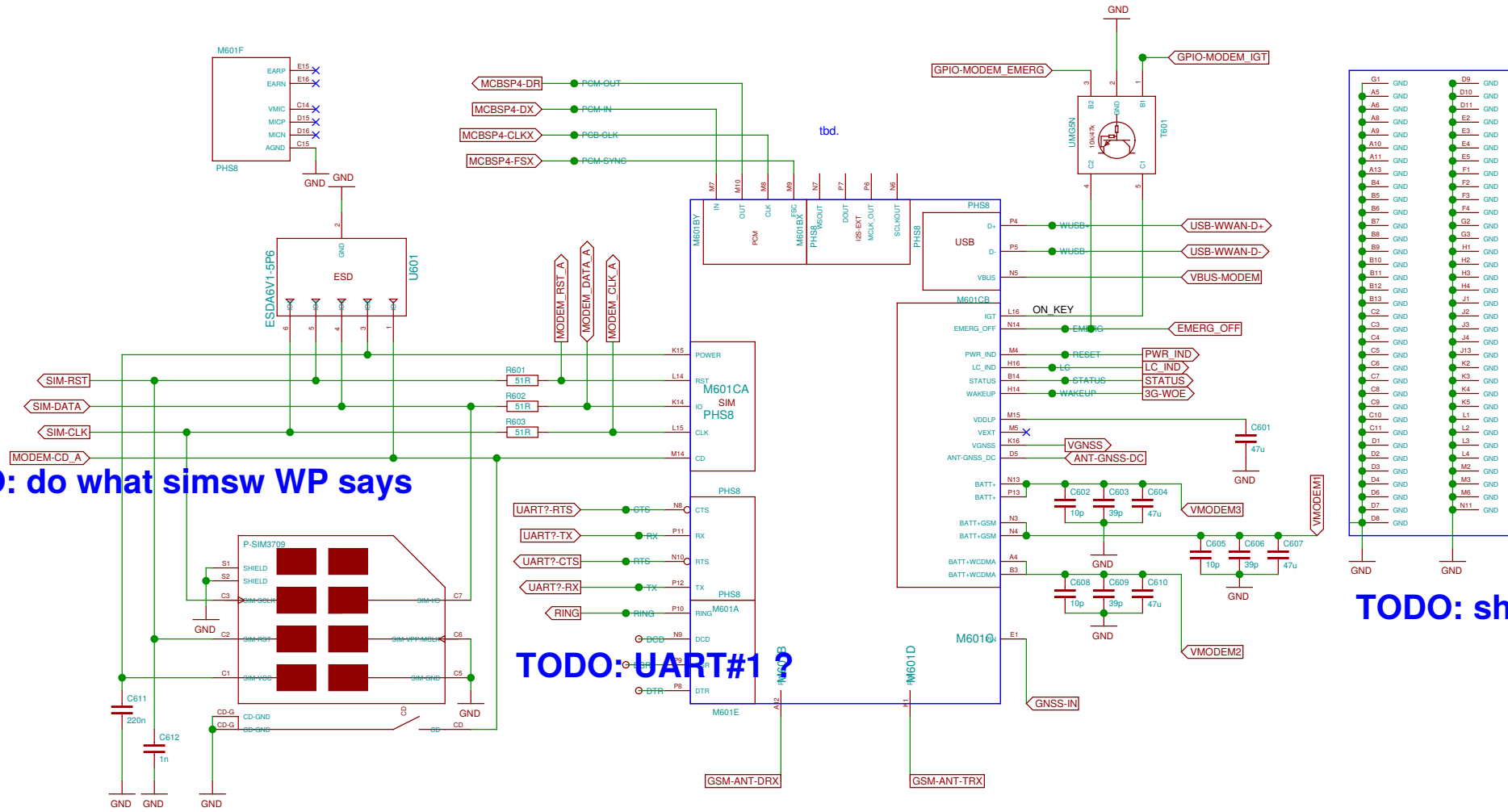

TODO: not cleaned up - needs total rewrite

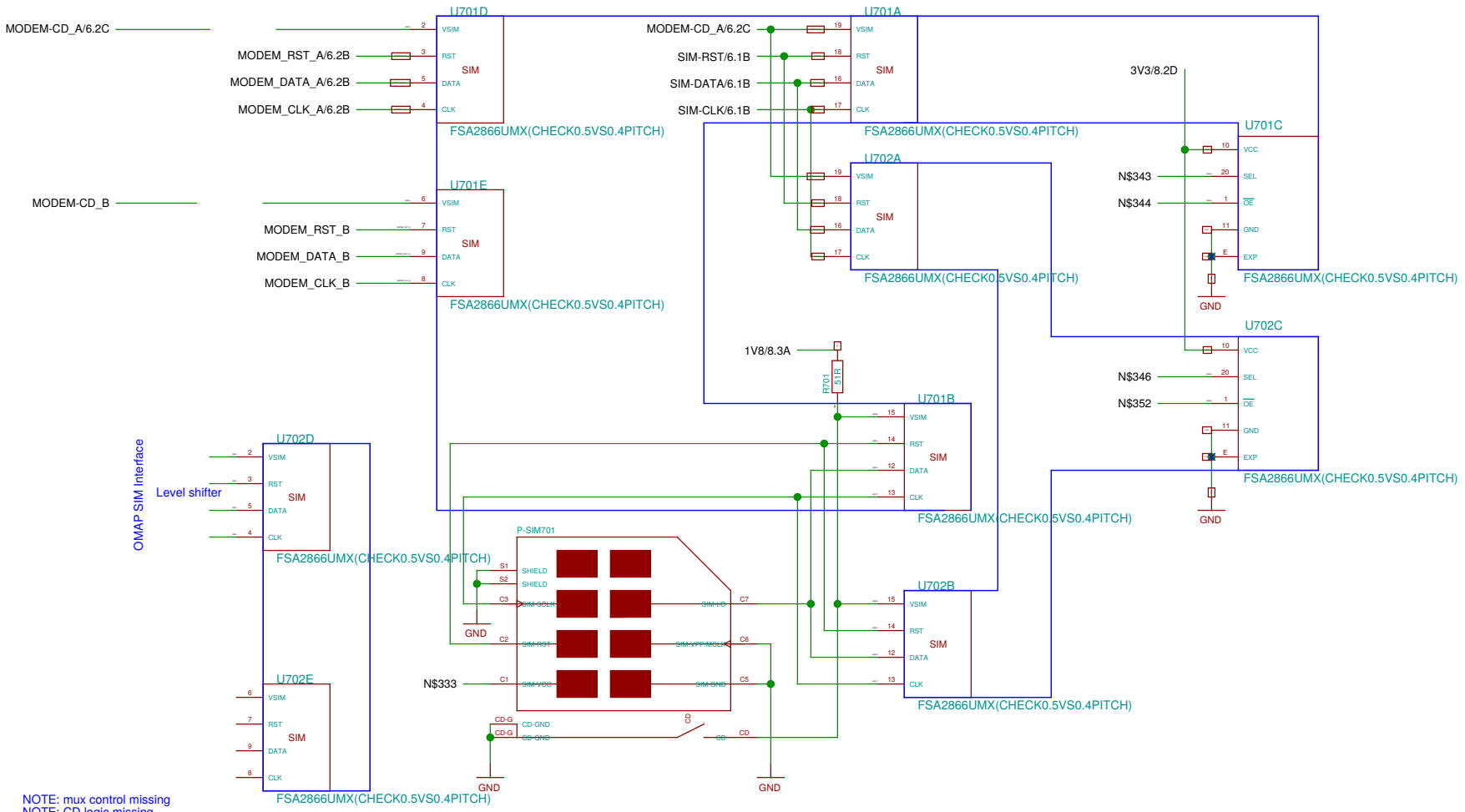

NOTE: mux control missing
 NOTE: CD logic missing
 NOTE: SIM power supply missing

TODO: fix VGNSS logic

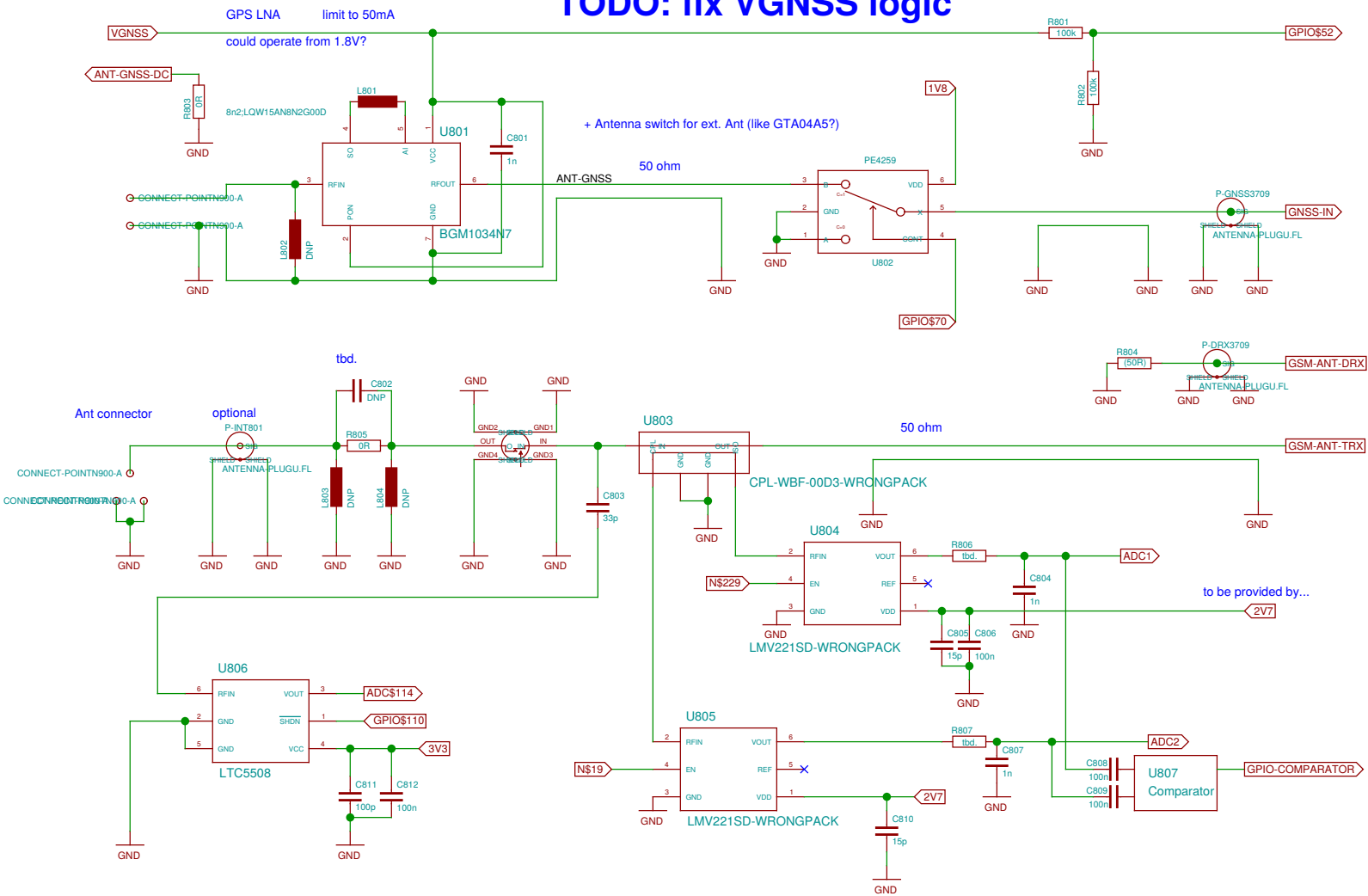

TODO: name all the *\$*

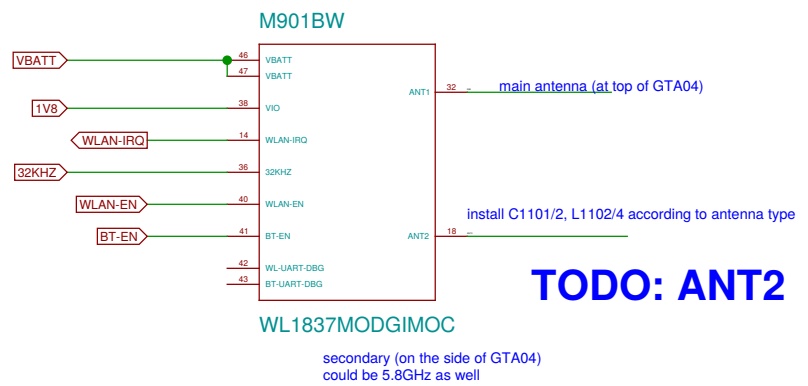

TODO: ANT2

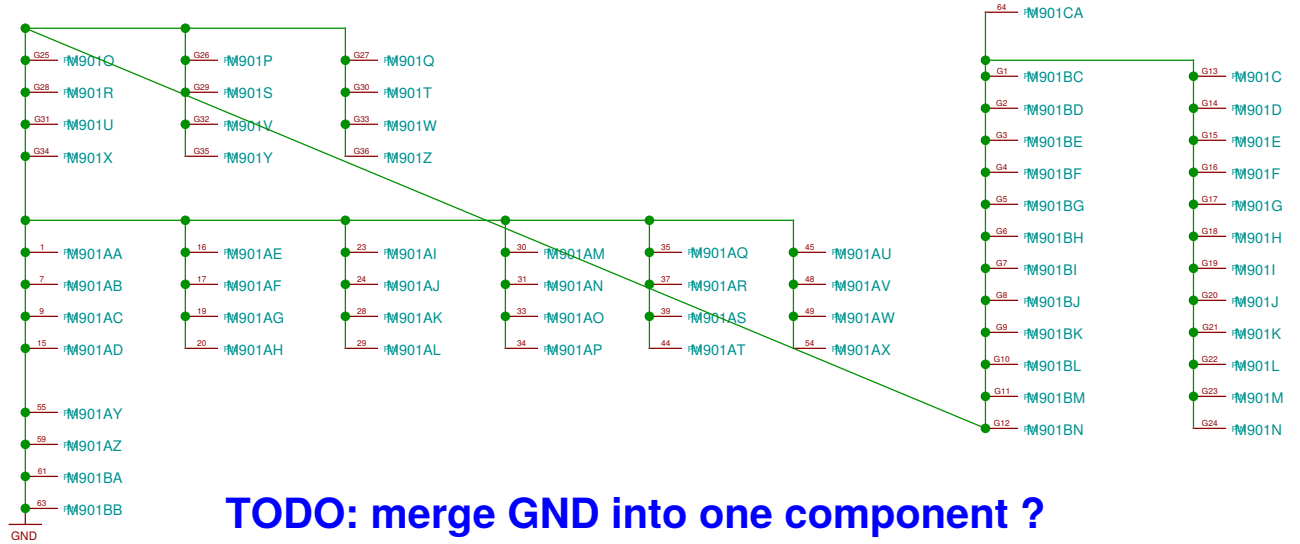

TODO: merge GND into one component ?

TODO: unfinished

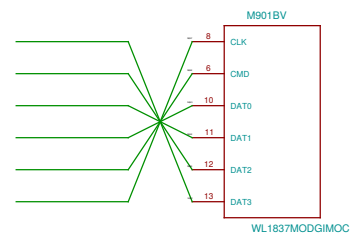
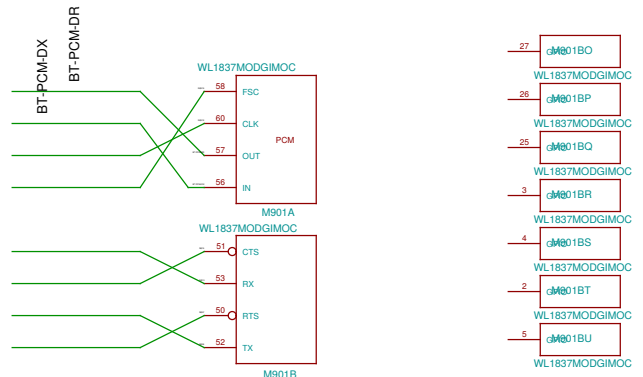

- WLAN-IRQ
- WLAN-EN
- BT-EN
- GPIO175
- KEYIRQ

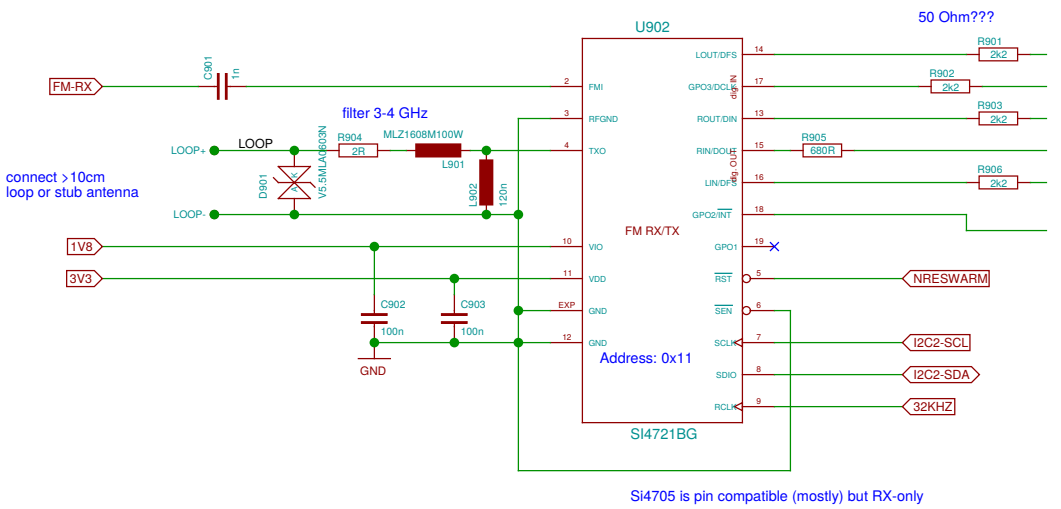

Si4705 is pin compatible (mostly) but RX-only

TODO: unfinished

- FSX
- CLKX
- DX
- DR
- FSR
- CLKR

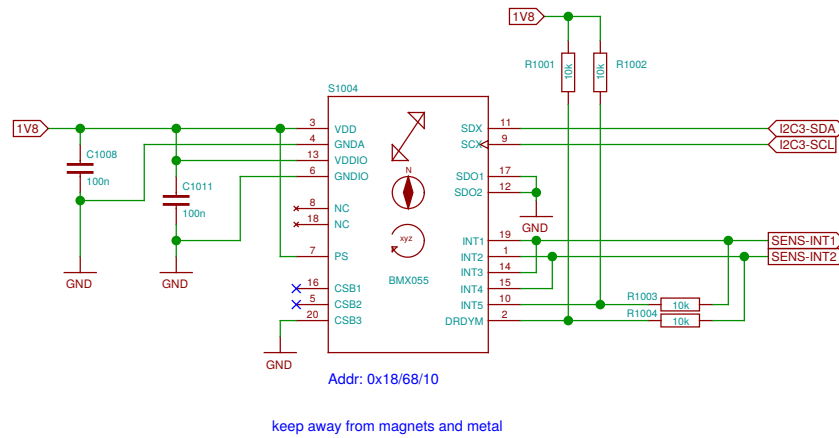
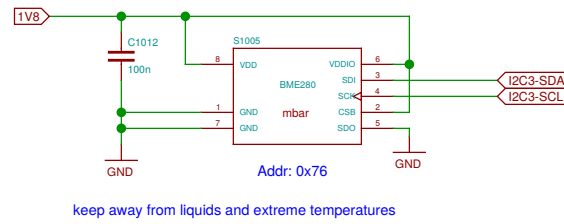
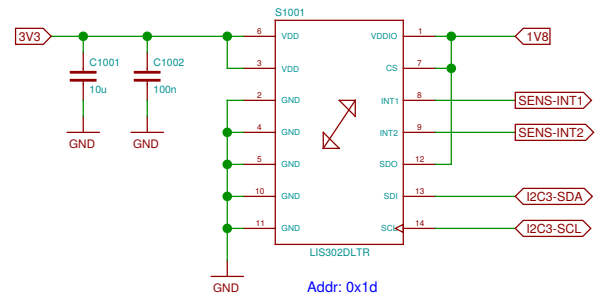

| | | |
|--|----------|-----------|
| Sheet: /Sensors/ File: neo900_SS_10.sch | | |
| Title: Sensors | | |
| Size: %Z | Date: %D | Rev: %R |
| %K | | Id: 10/37 |

problem: this is a 0.5mm BGA making lower board expensive
 but it appears to be not extremely critical (only 3 rows and inner ring is GND)
 problem: analog mic is on upper board
 alternative: place on upper board (to be evaluated)

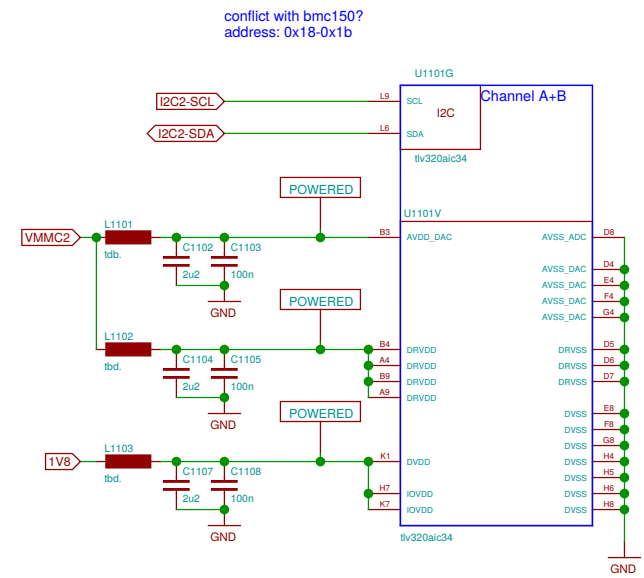
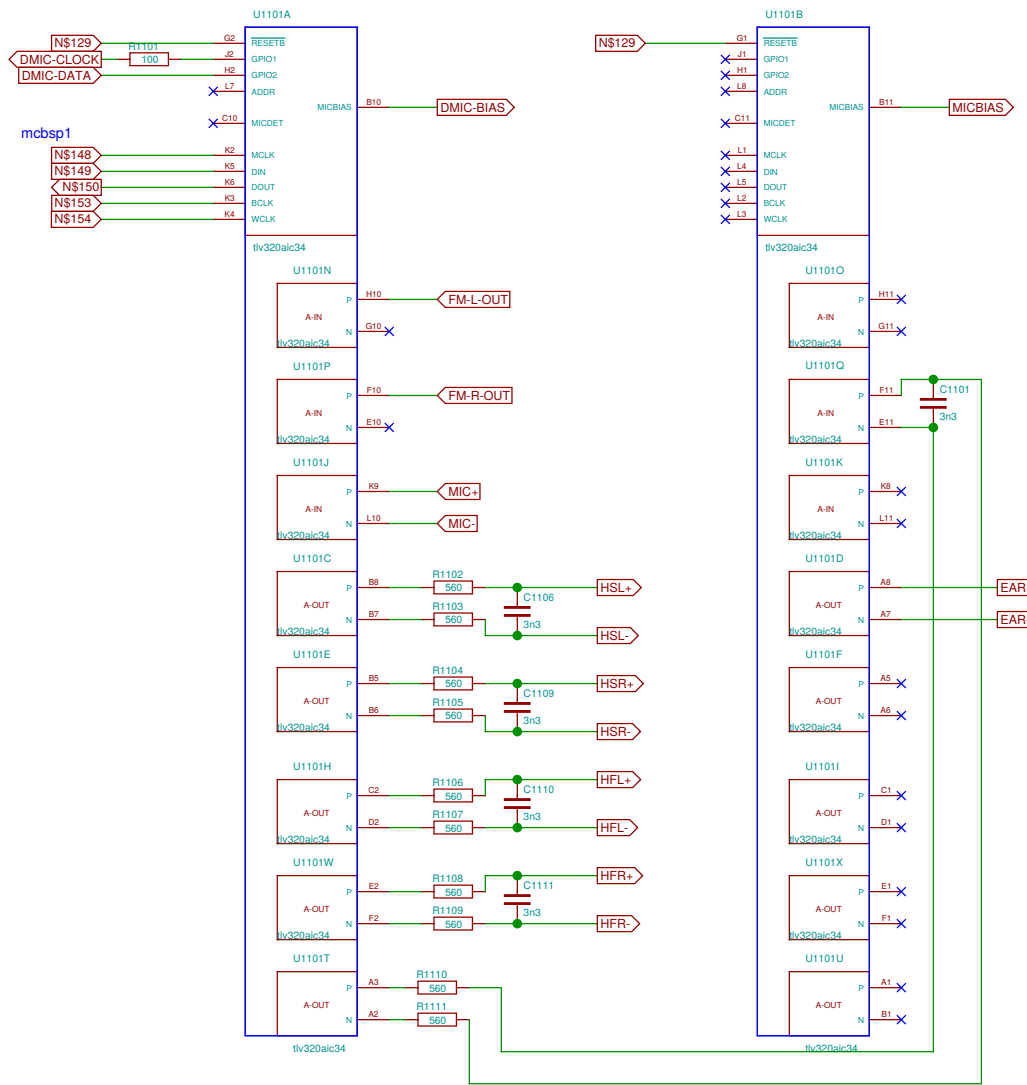

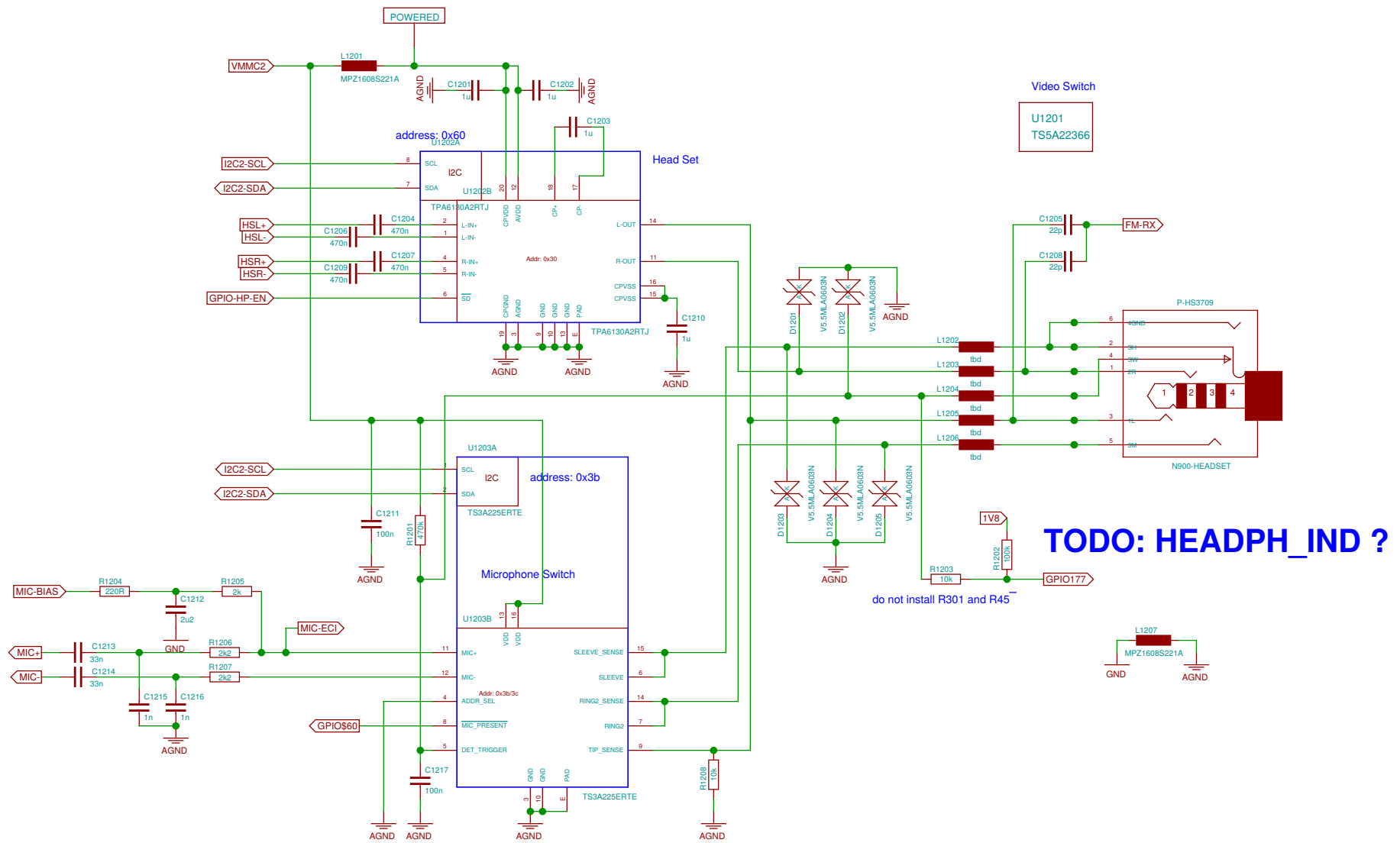

| | | | |
|------------------------------|----------|-----------|--|
| Sheet: /Audio Headset + Mic/ | | Rev: %R | |
| File: neo900_SS_12.sch | | Id: 12/37 | |
| Title: Audio Headset + Mic | | | |
| Size: %Z | Date: %D | | |

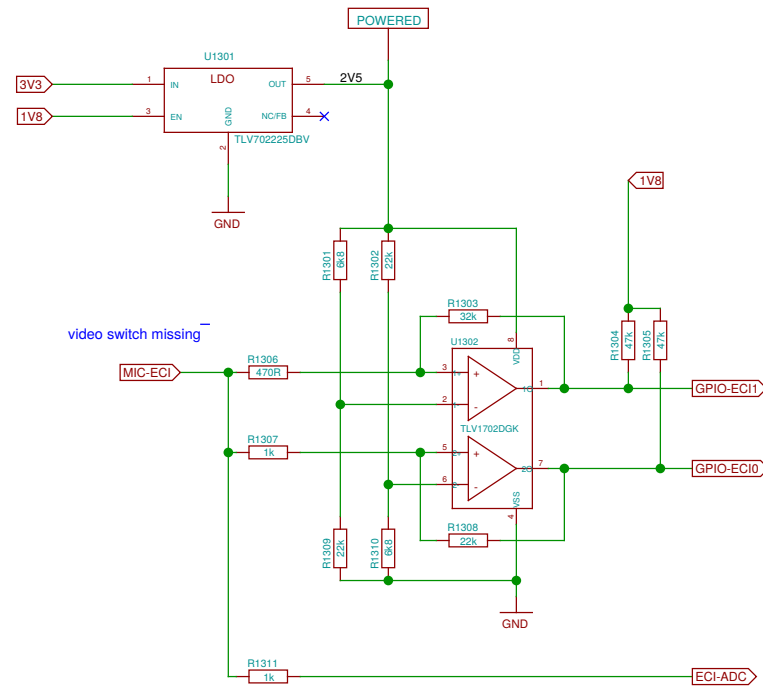

video switch missing

TODO: draw comparator right

| | | | |
|--------------|----------|------------------------|-----------|
| Sheet: /ECI/ | | File: neo900_SS_13.sch | |
| Title: ECI | | | |
| Size: %Z | Date: %D | Rev: %R | Id: 13/37 |
| %K | | | |

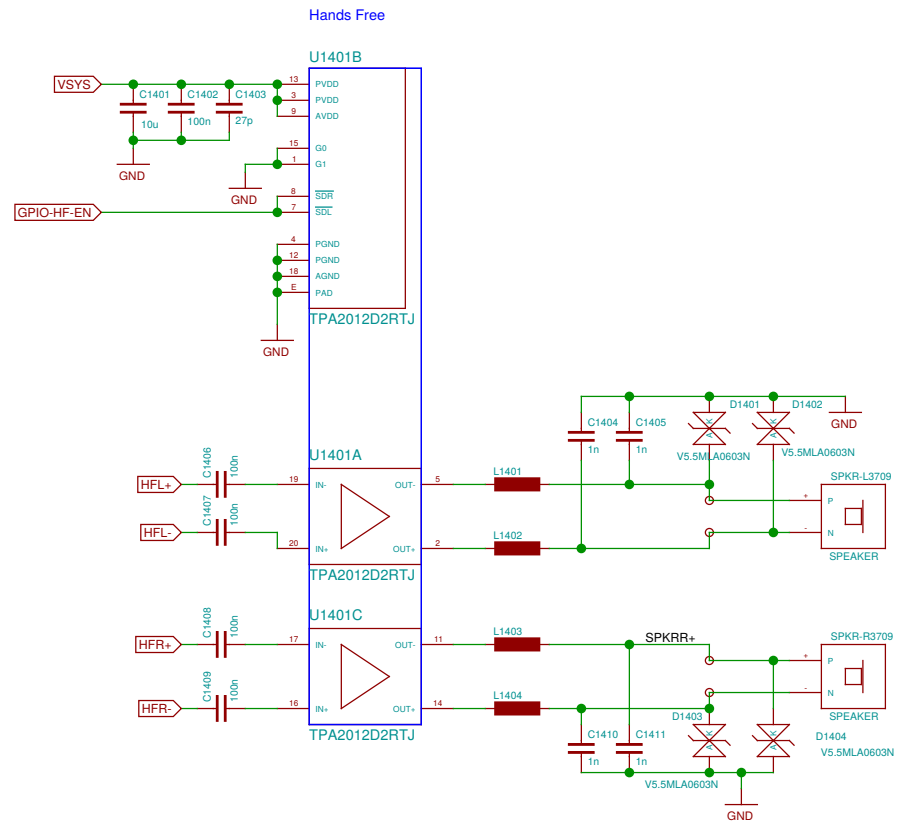

| | | |
|--|----------|-----------|
| Sheet: /Audio Handsfree/ File: neo900_SS_14.sch | | |
| Title: Audio Handsfree | | |
| Size: %Z | Date: %D | Rev: %R |
| %K | | Id: 14/37 |

The LOWER-BOB interconnect is defined in the Hackerbus specification
<http://neo900.org/stuff/papers/hb.pdf>

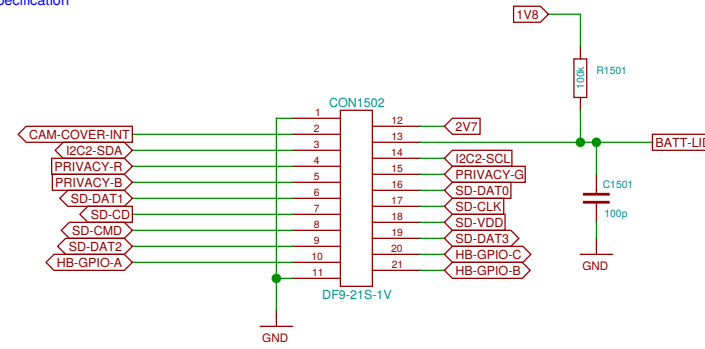
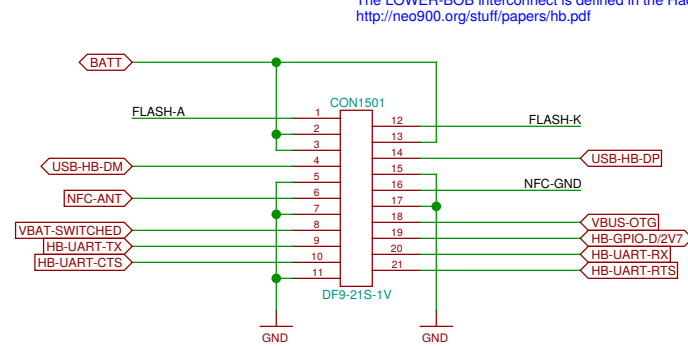

TODO: define NFC-GND

Vibrator

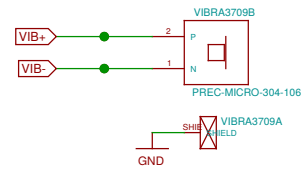

Shield

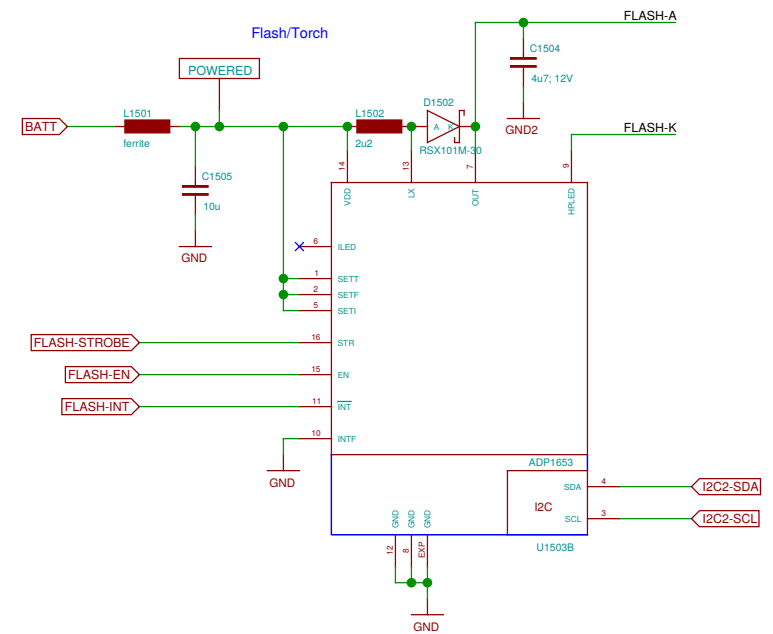
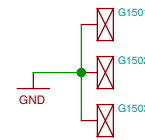

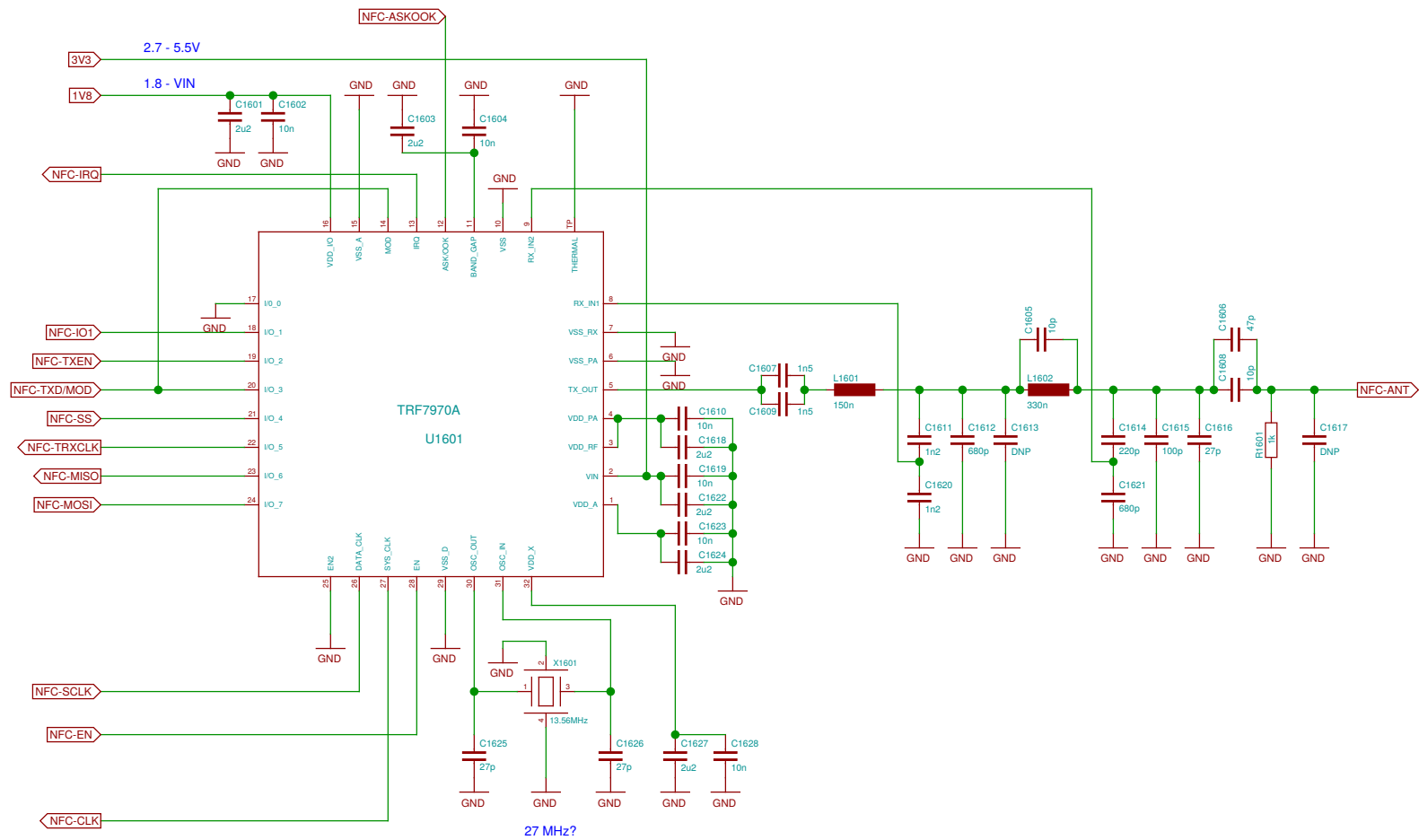

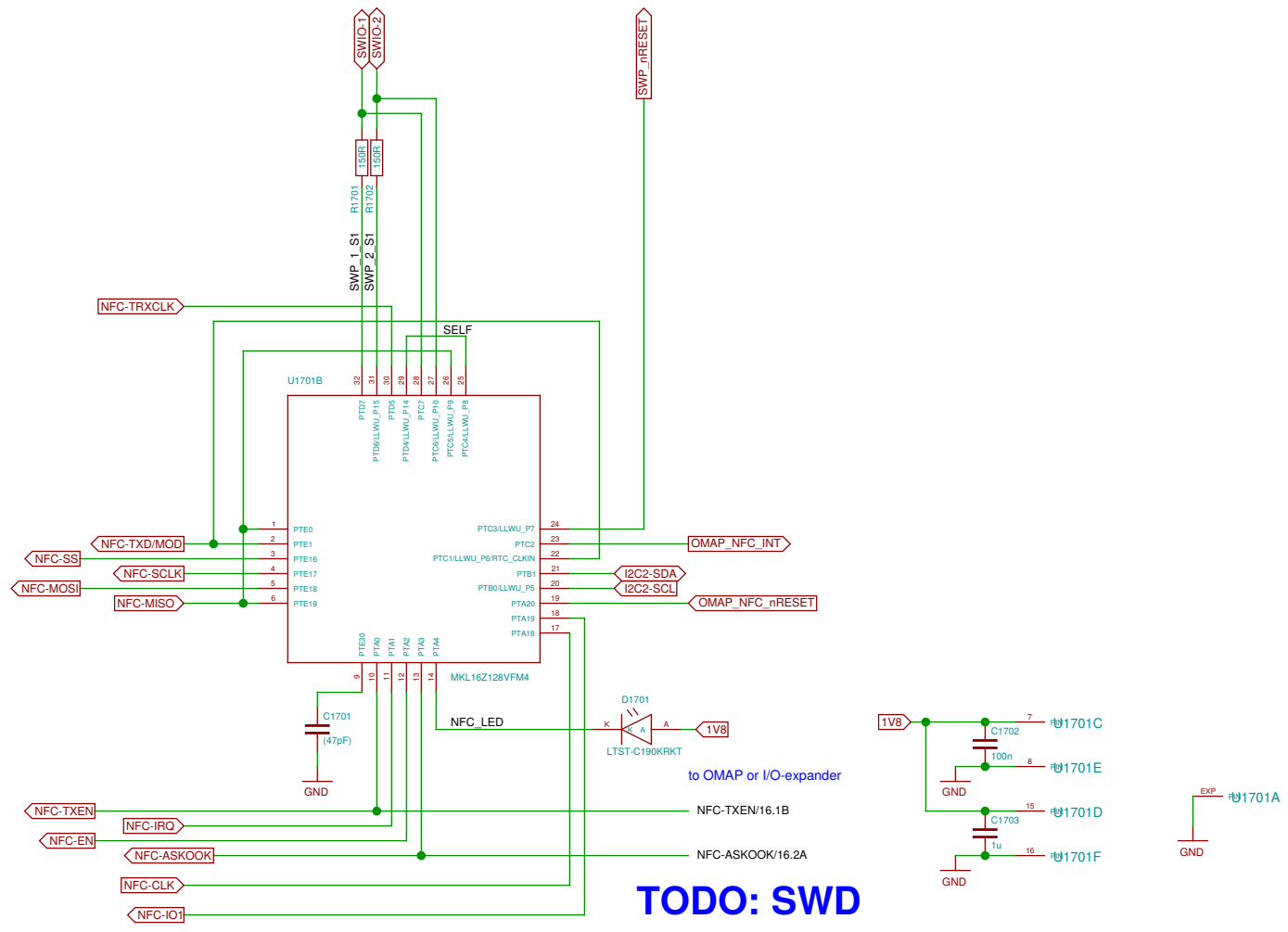

TODO: SWD

NOTE: this is mangling up Breakout and Lower board connectors
Signals may have to be fed through the breakout board connector increasing resistance

TODO: align with HB WP

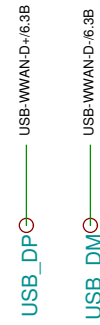

TODO: HB "base circuit" (level shifters, etc.) goes here

Missing 10 level shifter chip (or do we really have the space for 10x discrete T+R+D ca. 3x3mm each?)

Missing 6x 2R for alternate function select (do we have the space for ca. 2.5 x 5mm?)

| | | |
|--|----------|-----------|
| Sheet: /Hackerbus/ File: neo900_SS_18.sch | | |
| Title: Hackerbus | | |
| Size: %Z | Date: %D | Rev: %R |
| %K | | Id: 18/37 |

TODO: update D1901 footprint

NOTE: 1V8 may be quite noisy

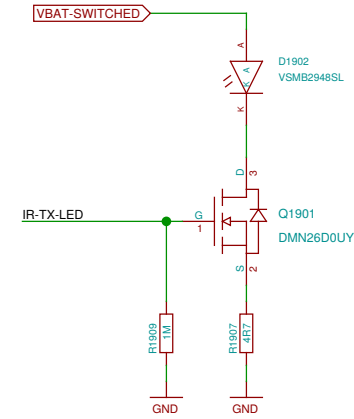
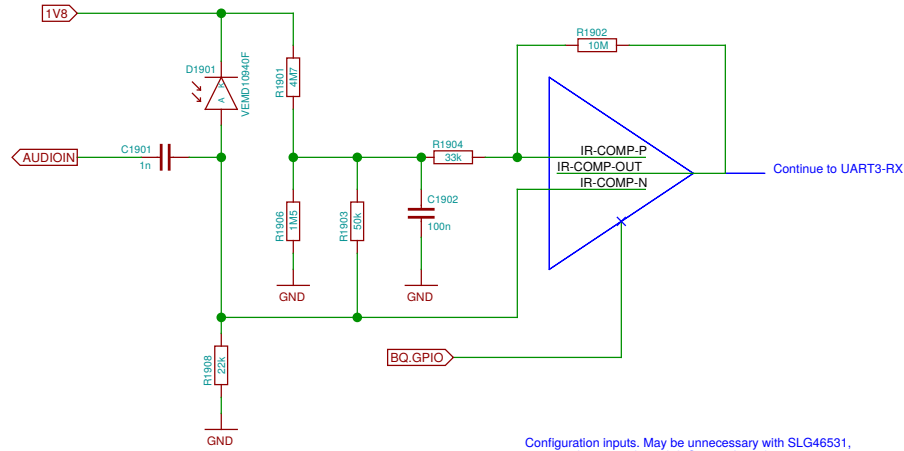

Configuration inputs. May be unnecessary with SLG46531, once configuration through I2C is confirmed.

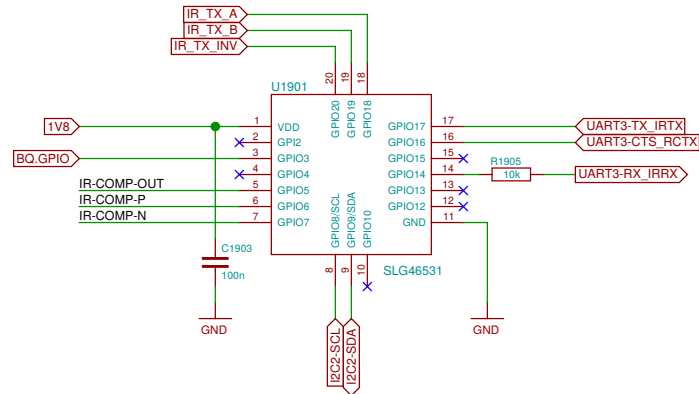

TODO: update when details settle

ca. 130 signals (to be counted exactly after definition of upper/lower split)

- MMCS-DATA1/9.1A
- MMCS-DATA2/9.1A
- MMCS-DATA3/9.1A
- GPIO-WLAN-IRQ/9.1A
- GPIO-BT-EN/9.1C
- UART1-RX/9.1C
- UART1-RTS/9.1C
- UART1-CTS/9.1D
- UART1-TX/9.1D
- MCBSP3-FCK/9.1D
- MCBSP3-CLK/9.1D
- MCBSP3-DR/9.1D
- MCBSP3-DX/9.1D
- SYSCLK/9.3C
- 32KHZ/9.4A
- GPIO-FM-EN/9.3A
- GPIO-FMIRQ/9.3A
- MCBSP2-FCK/9.3A
- MCBSP2-CLK/9.3A
- MCBSP2-DR/9.3A
- MCBSP2-DX/9.3A
- GPIN115/10.3B
- GPIO56/10.3A
- GPIO51/10.3B
- GPIO55/10.4A
- GPIO56/10.4A
- ACCEL-INT/10.4C
- NS129/11.2A
- NS148/11.1A
- NS149/11.1A
- NS150/11.1A
- NS153/11.1A
- NS154/11.1A
- GPIO-ECI1/13.3B
- GPIO-ECI0/13.3C
- ECI-ADC/13.3C
- VMMC2/12.1A
- GPIO-HP-EN/12.1B
- GPIO560/12.2D
- GPIO177/12.4C
- GPIO-HF-EN/14.1B
- GPIO-FLASH-STR/15.1A
- GPIO-FLASH-EN/15.1A
- GPIO-FLASH-INT/15.1A
- GPIO-BATT-LID/15.1B
- SD-CMD/15.2A
- SD-CLK/15.2A
- SD-CD/15.2B
- SD-VDD/15.2A
- SD-DAT0/15.2B
- SD-DAT1/15.2B
- SD-DAT2/15.2A
- SD-DAT3/15.2A
- VIB+/15.1D
- VIB-/15.1D
- 3V3/19.1D
- 2V5/13.3B
- 1V8/19.1D
- VBUS/18.1C
- OTG-D-/3.1B
- OTG-D+/3.1B
- OTG-ID/2.2B
- VBUS-MODEM/6.3B
- USB-WWAN-D+/18.3A
- USB-WWAN-D-/18.3A
- 2V7/8.4C
- GPIO-CAM-COVER/15.1B
- NS38
- LOCK-GPIO/1.2A
- POWERON/1.3A
- GPIO-VOL+/1.2B
- GPIO-VOL-/1.2B
- CAM1-GPIO/1.3B
- CAM2-GPIO/1.3C
- I2C3-SDA/10.4C
- I2C3-SCL/10.4C
- CHG_IND/3.1B
- NS131/3.1C
- NS141/3.1C
- NS143/3.1C
- BATTEMP/5.4A
- GPIO-EN-MODEM/4.1A
- I2C2-SDA/15.1A
- I2C2-SCL/15.1A
- INA231-INT/4.4C
- HDO/5.2A
- GPIO570/8.3B
- GPIO5110/8.1D
- NS19/8.2D
- NS229/8.3C
- ADC5114/8.1C
- ADC1/8.4C
- ADC2/8.4C
- GPIO-COMPARATOR/8.4D
- MCBSP4-DR/6.2A
- MCBSP4-DX/6.2A
- MCBSP4-CLKX/6.2A
- MCBSP4-FSX/6.2A
- UART7-RTS/6.2C
- UART7-CTS/6.2C
- UART7-RX/6.2C
- UART7-TX/6.2C
- RING/6.2C
- GPIO-MODEM_IGT/6.3A
- GPIO-MODEM_EMERG/6.3A
- EMERG_OFF/6.3B
- PWR_IND/6.3B
- LC_IND/6.3B
- STATUS/6.3B
- 3G-WOE/6.3B
- GPIO52/8.4A
- GPIO-WLAN-EN/9.1A
- MMC3-CLK/9.1A
- MMC3-CMD/9.1A
- MMC3-DATA0/9.1A

Pin assignment must be optimized for final component placement
we might have to switch to 80 or 100 pin connectors

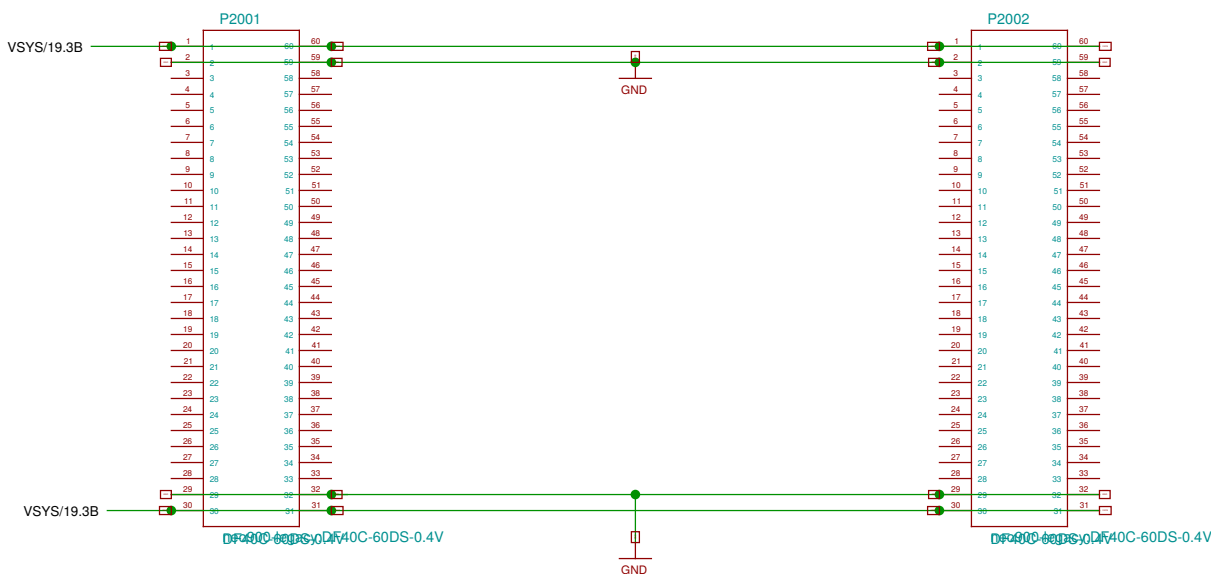

TODO: add ESD protection (here)

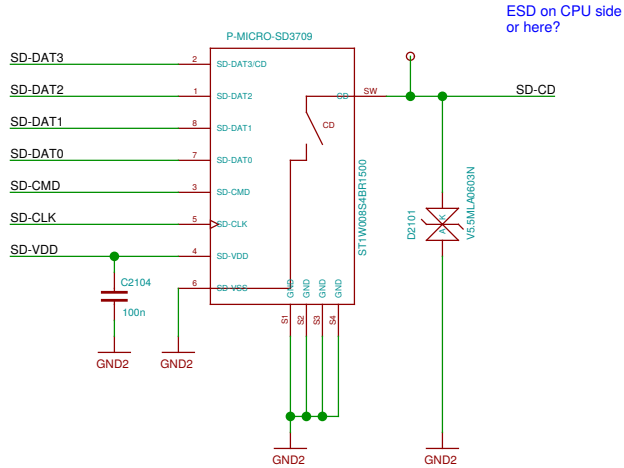
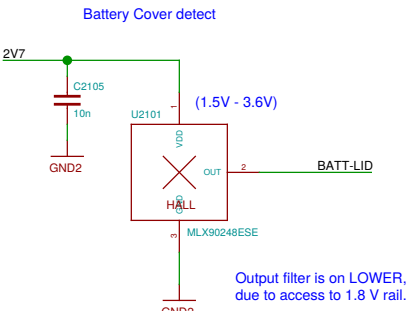
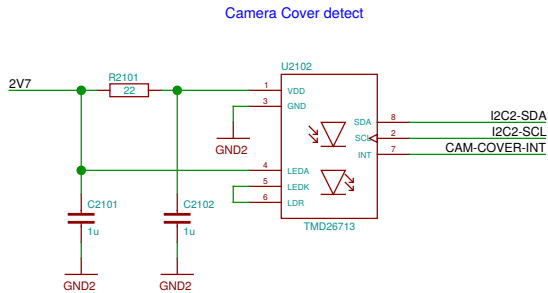

The LOWER_BOB interconnect is defined in the Hackerbus specification <http://neo900.org/stuff/papers/hb.pdf>

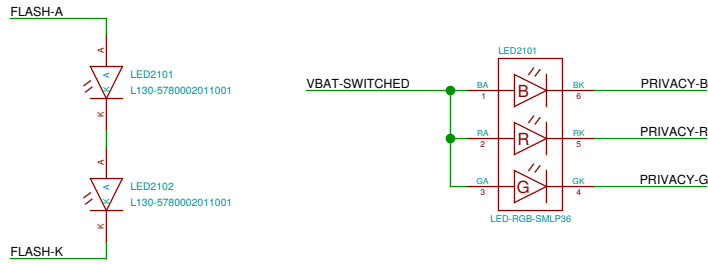
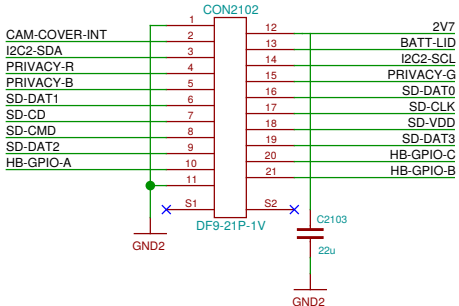
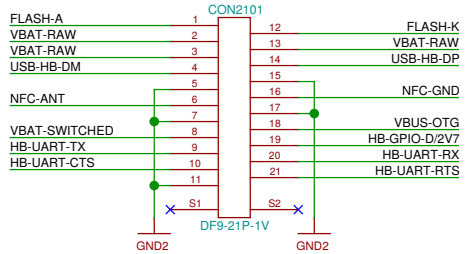

TODO: CON2101/2101 have metal fitting

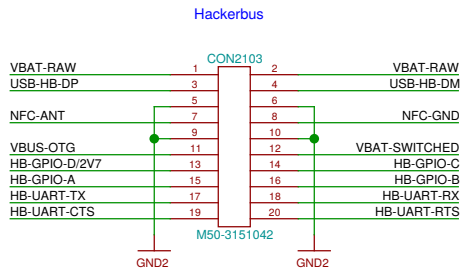

TODO: track B2B to UPPER



to be adjusted to lower board connector

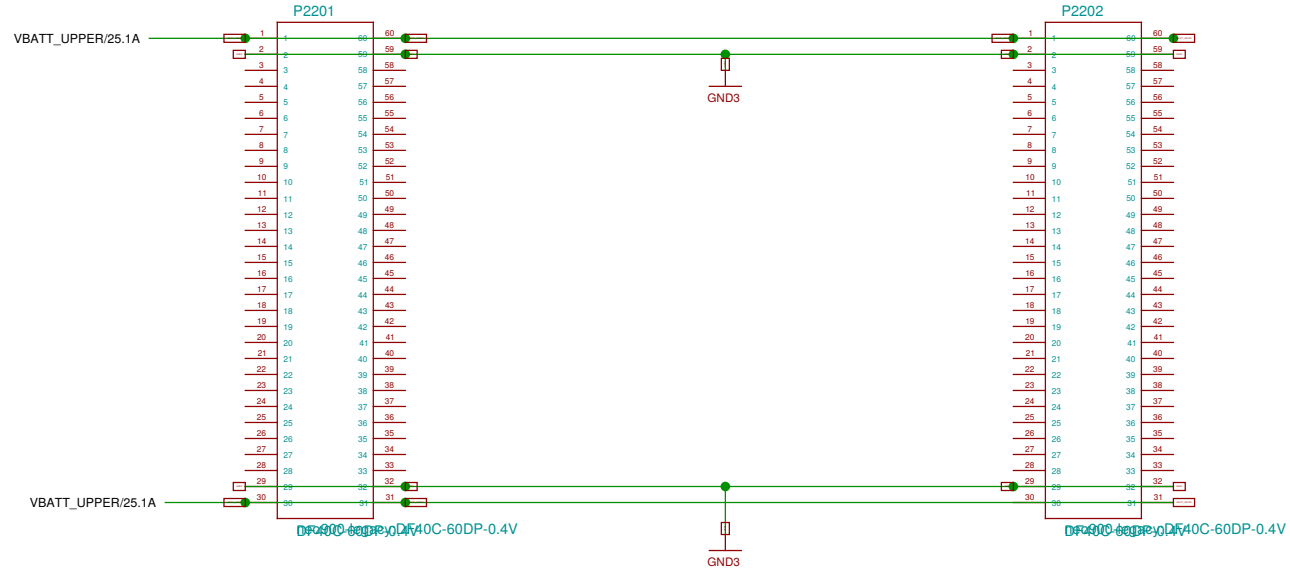

SHIELD

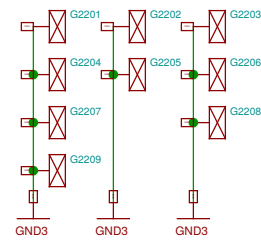

| | | |
|---|----------|-----------|
| Sheet: /B2B to LOWER/ File: neo900_SS_22.sch | | |
| Title: B2B to LOWER | | |
| Size: %Z | Date: %D | Rev: %R |
| %K | | Id: 22/37 |

TODO: *_UPPER names ?

needs final tuning (which button on which position)
VOL+ and VOL- could drive FETs sitting in the matrix

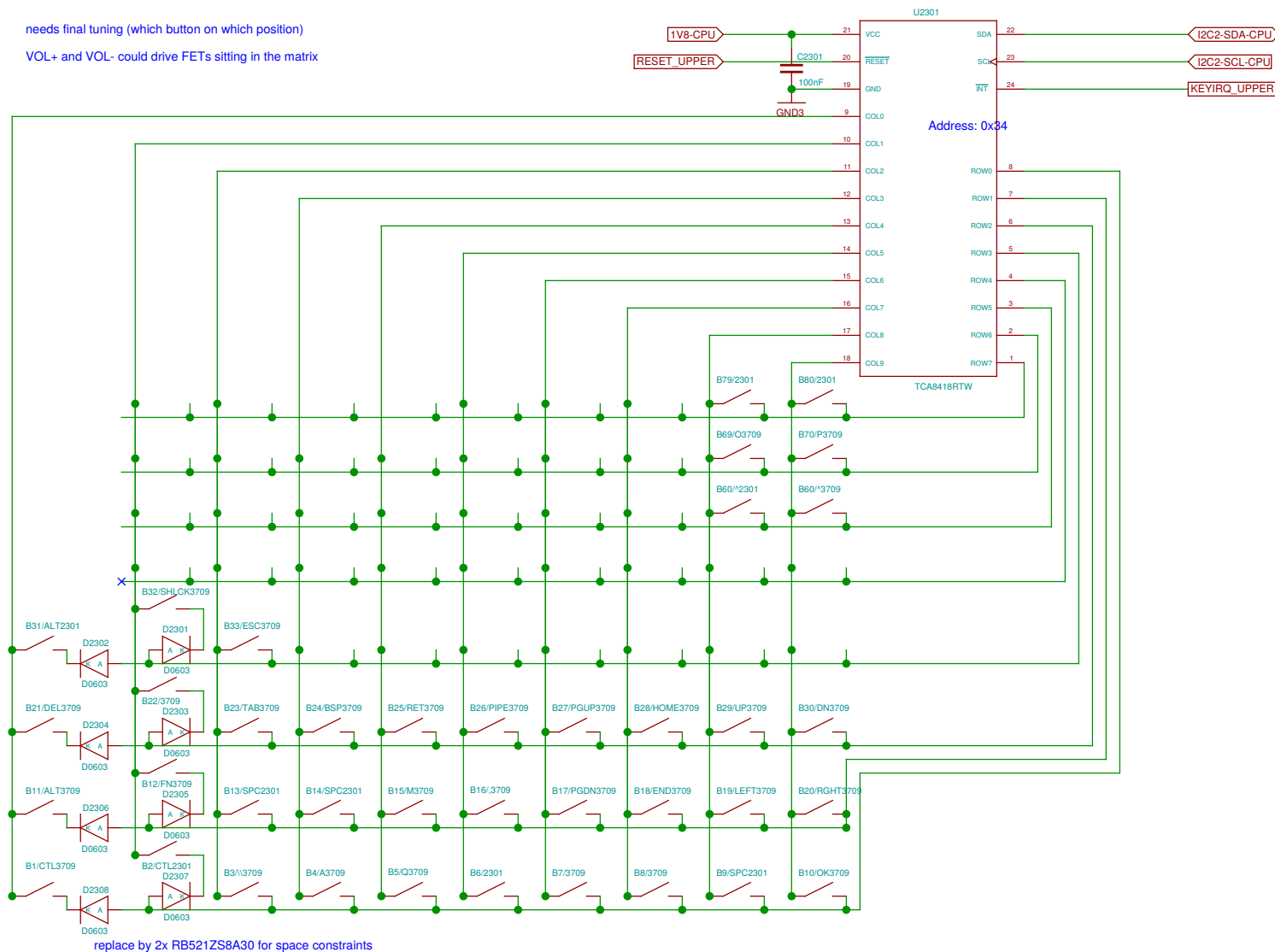

- TODO: remove 3709 in comp ref**
- TODO: remove keycap from comp ref**
- TODO: sort out 6 "ext" buttons**
- TODO: rearrange matrix to avoid diodes ?**

| | |
|---|----------------------|
| Sheet: /Keypad/ File: neo900_SS_23.sch | |
| Title: Keypad | |
| Size: %Z | Date: %D |
| %K | Rev: %R Id: 23/37 |

Resistive Touch (display connector)

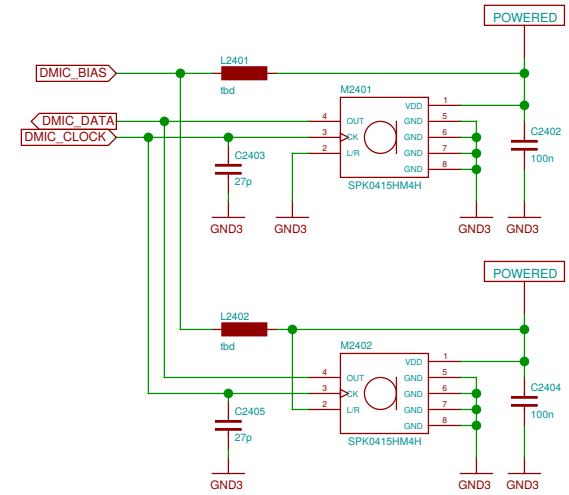
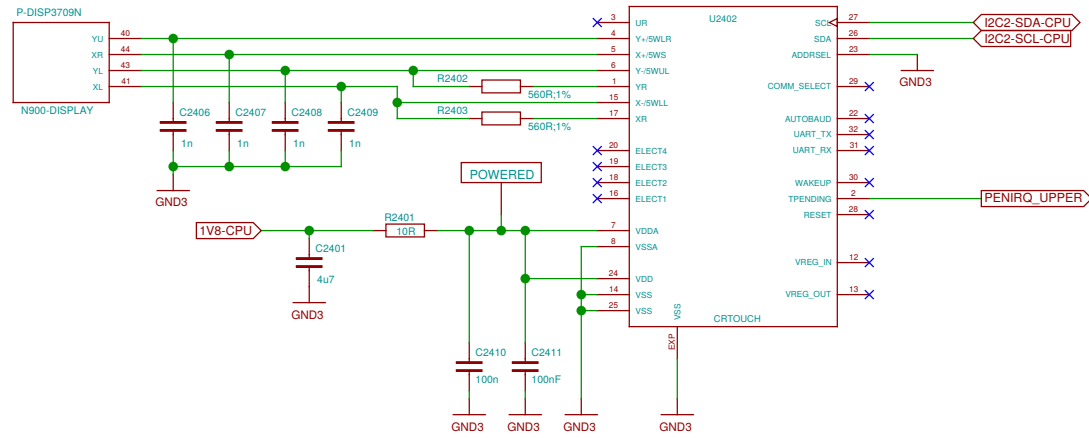

TODO: connector pin assignment needs intensive review

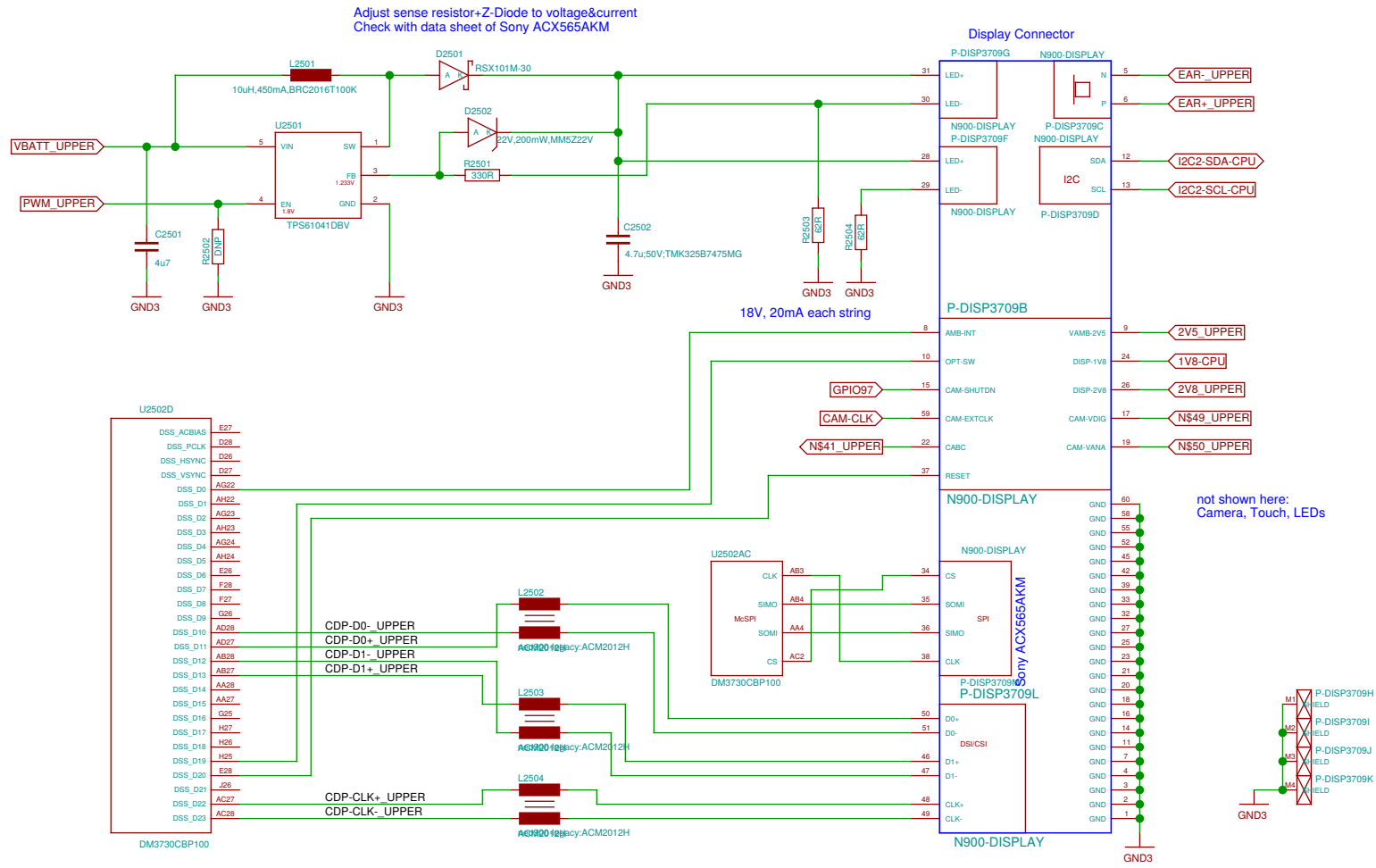

INCOMPLETE in V2

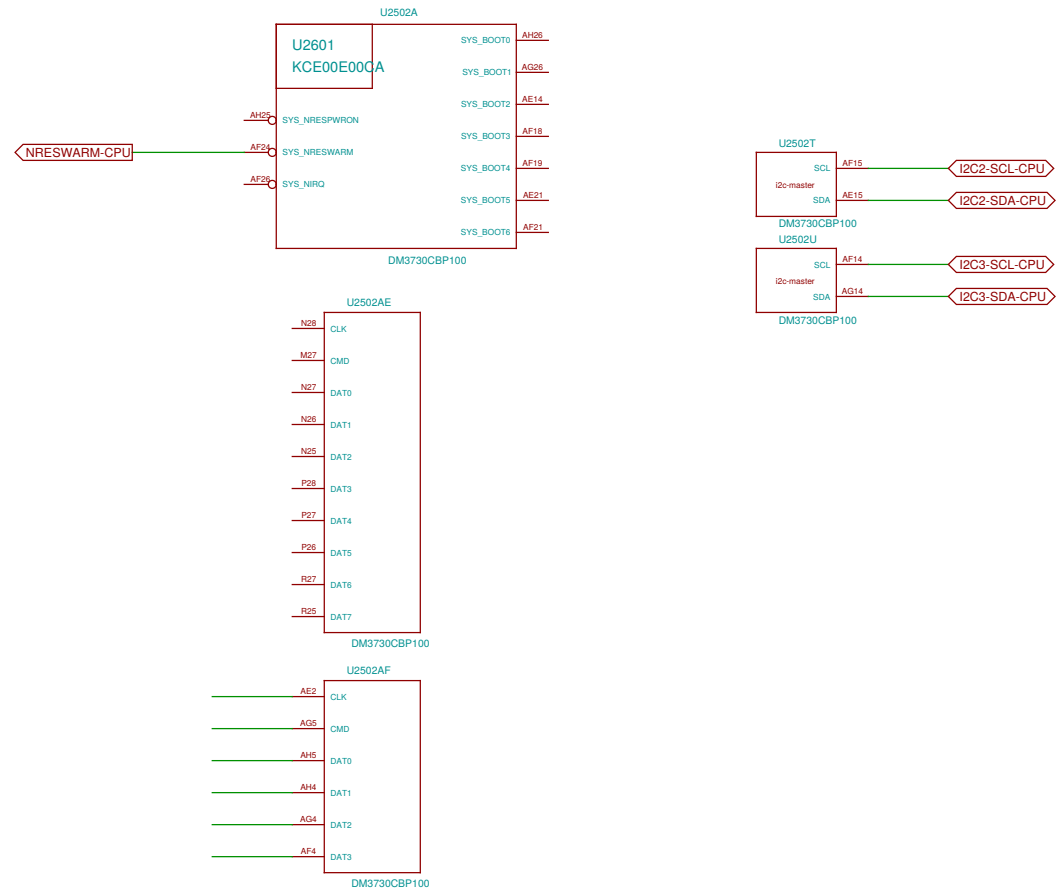

| | | |
|---|----------|-----------|
| Sheet: /CPU + PoP RAM/NAND/ File: neo900_SS_26.sch | | |
| Title: CPU + PoP RAM/NAND | | |
| Size: %Z | Date: %D | Rev: %R |
| %K | | Id: 26/37 |

INCOMPLETE in V2

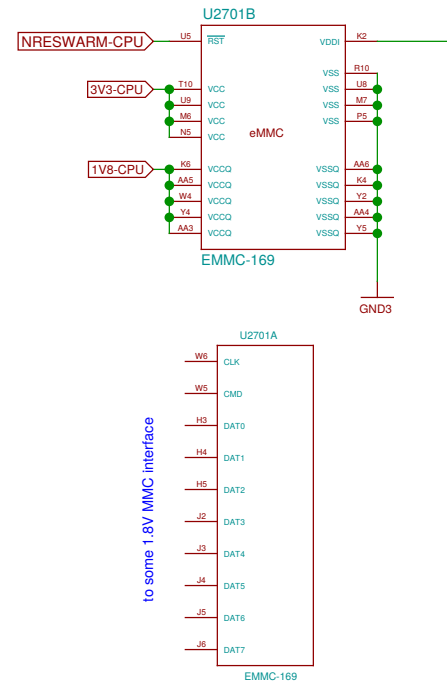

| | | |
|---|----------|-----------|
| Sheet: /eMMC/ File: neo900_SS_27.sch | | |
| Title: eMMC | | |
| Size: %Z | Date: %D | Rev: %R |
| %K | | Id: 27/37 |

TODO: check role

INCOMPLETE in V2

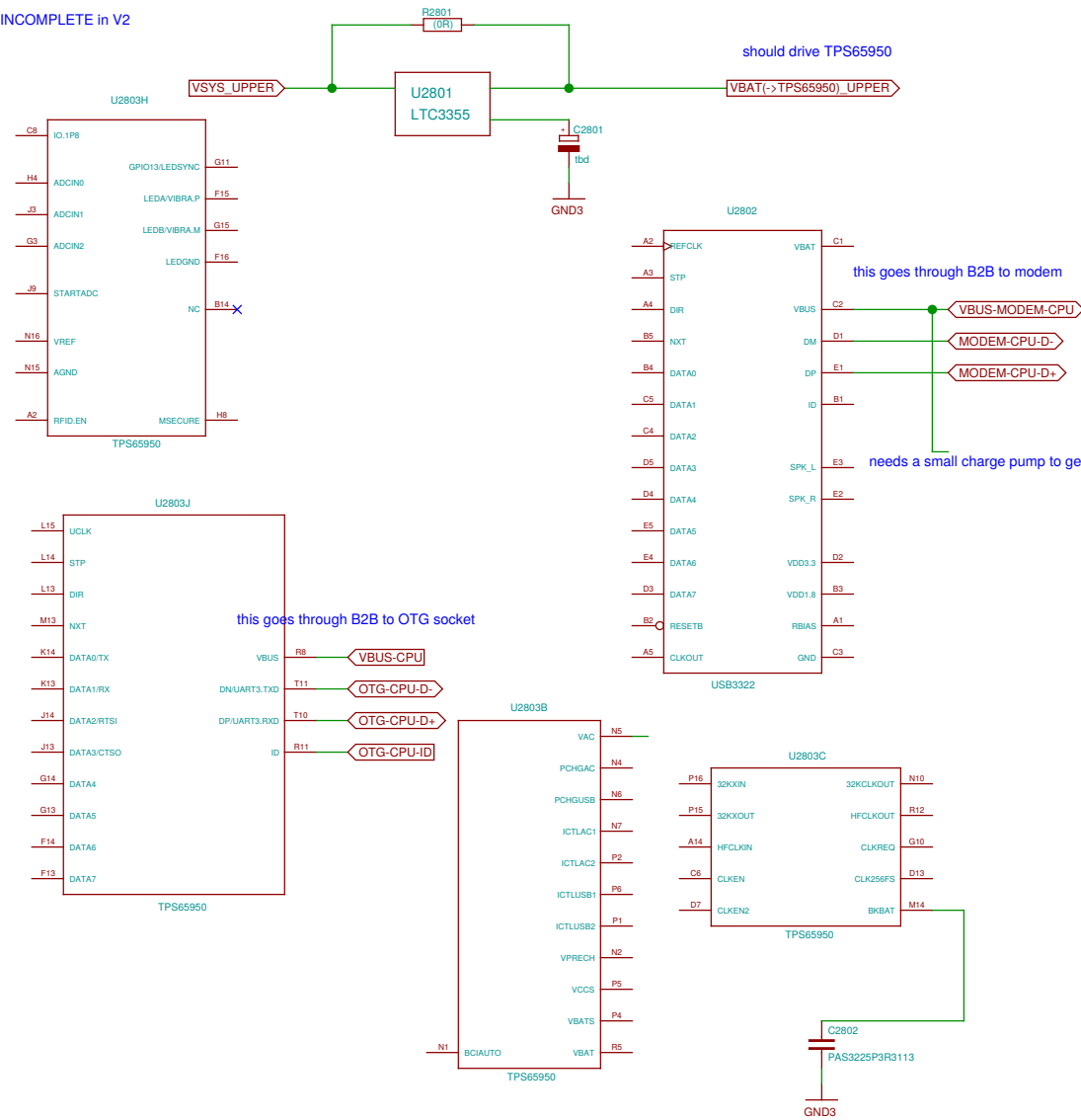

TODO: VBUS-MODEM ?

should drive TPS65950

this goes through B2B to modem

needs a small charge pump to generate 5V 50mA.

this goes through B2B to OTG socket

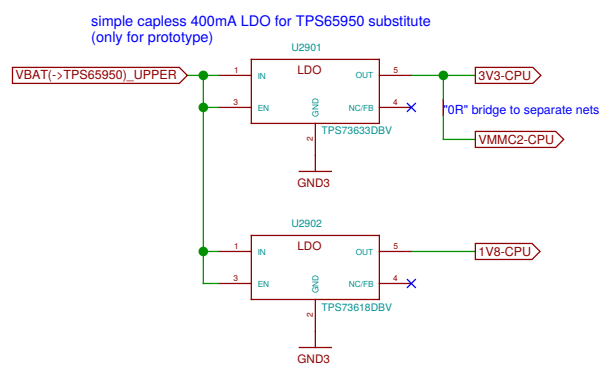

| | | |
|--------------------------------|----------|-----------|
| Sheet: /BB-XM Dummy (TWL4030)/ | | |
| File: neo900_SS_29.sch | | |
| Title: BB-XM Dummy (TWL4030) | | |
| Size: %Z | Date: %D | Rev: %R |
| %K | | Id: 29/37 |

INCOMPLETE in v2

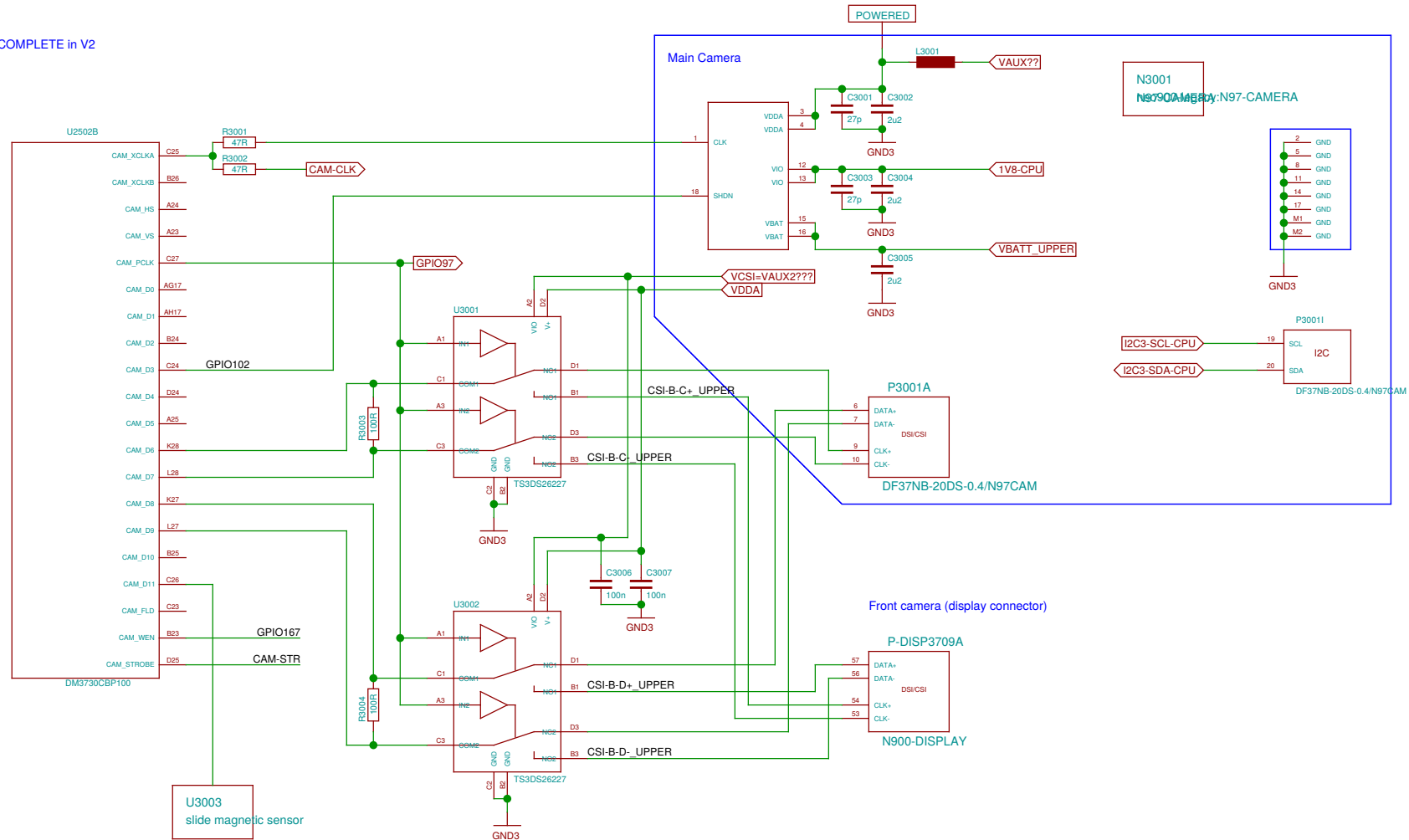

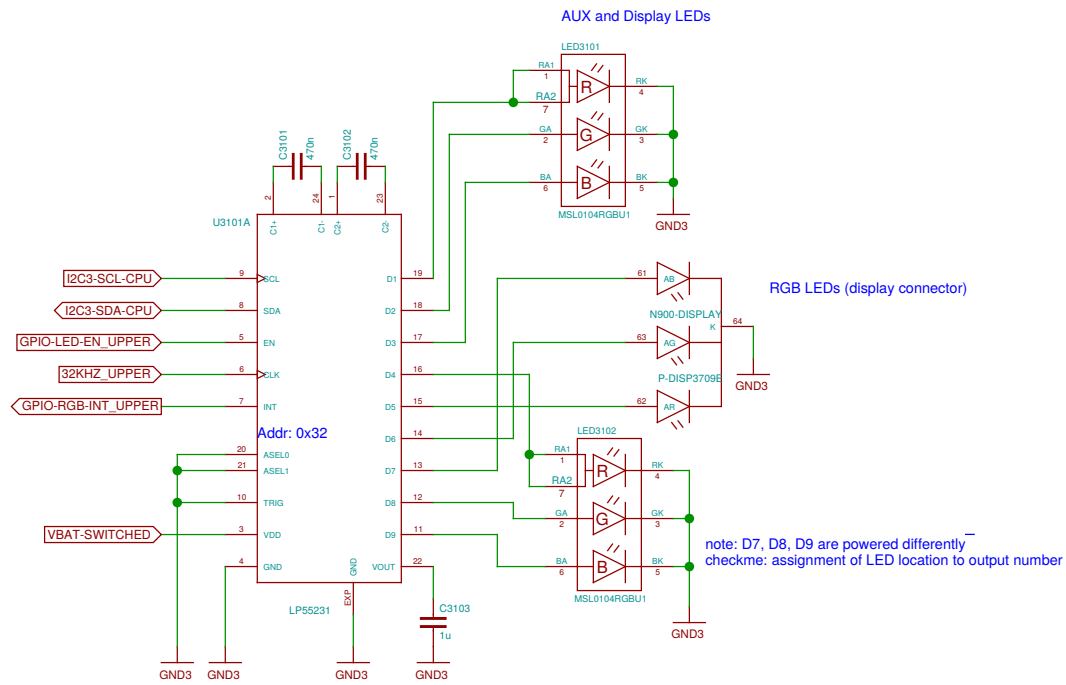

TODO: LEDs/Fancy LEDs sheets have title swapped

| | | |
|---|----------|-----------|
| Sheet: /LEDs/ File: neo900_SS_31.sch | | |
| Title: LEDs | | |
| Size: %Z | Date: %D | Rev: %R |
| %K | | Id: 31/37 |

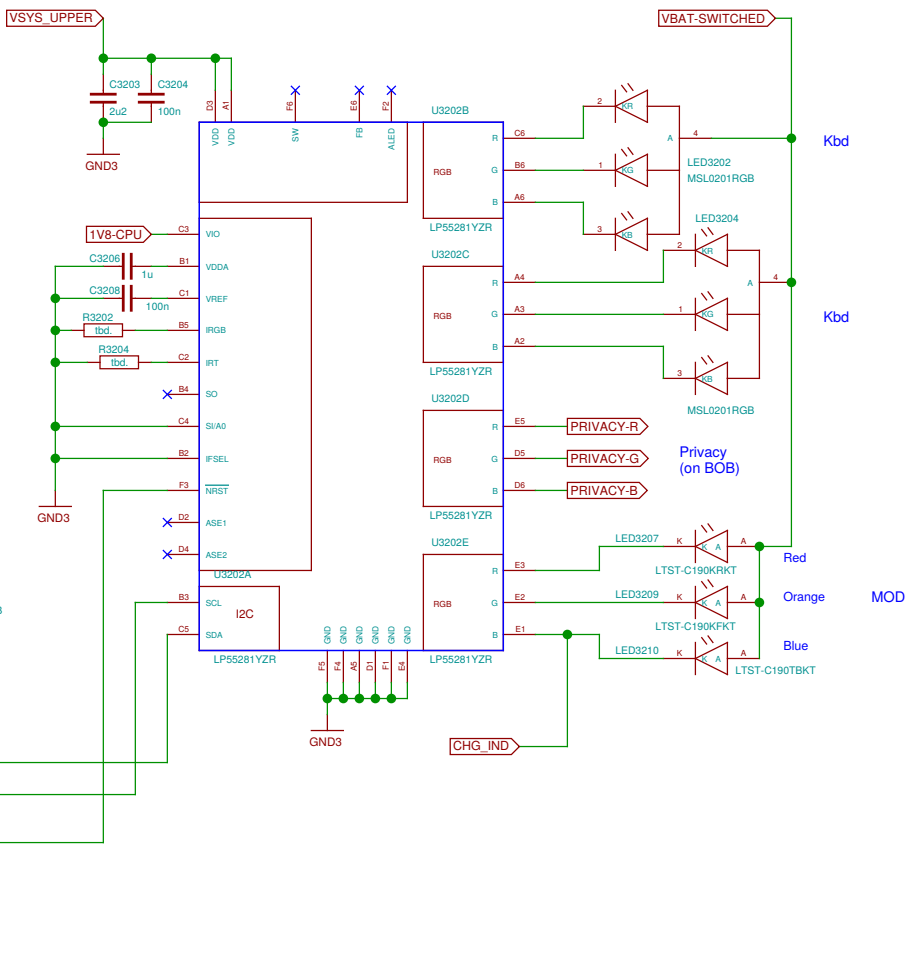
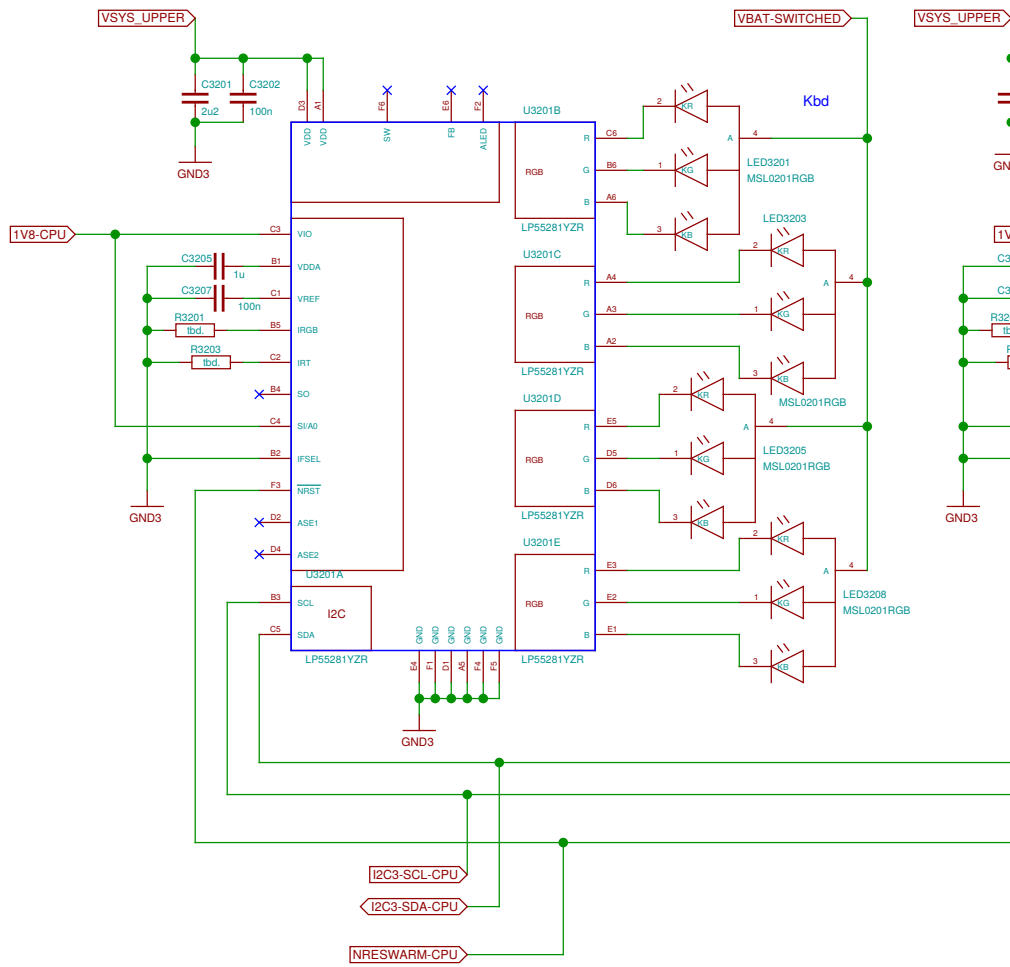

These connectors allow to "emulate" the DM3730 by connecting a BB-XM

INCOMPLETE
prototype only

Connect to OMAP3 McSPI1, I2C2, MMC2 / some GPIOs

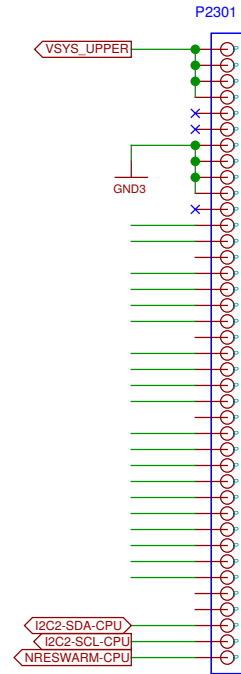

connect to respective CPU-pads

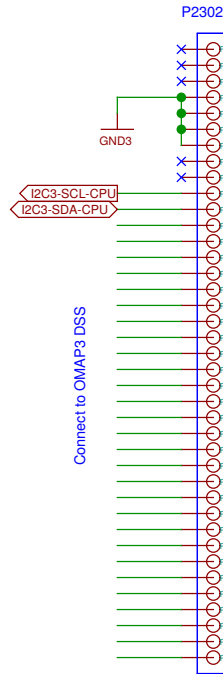

Connect to OMAP3 DSS

DSS / GPIOs, I2C3

Connect to OMAP3 Camera

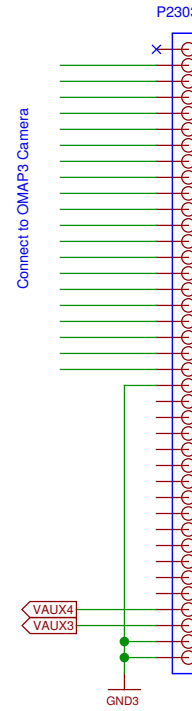

connect to BB
by some Micro-USB cable

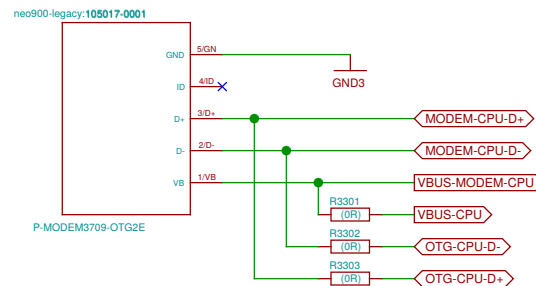

TODO: VBUS-MODEM ?

| | |
|---|----------------------|
| Sheet: /Connector to BB-XM/ File: neo900_SS_33.sch | |
| Title: Connector to BB-XM | |
| Size: %Z | Date: %D |
| %K | Rev: %R Id: 33/37 |

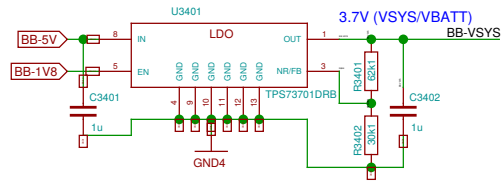

Ersetzen durch 2A buck converter

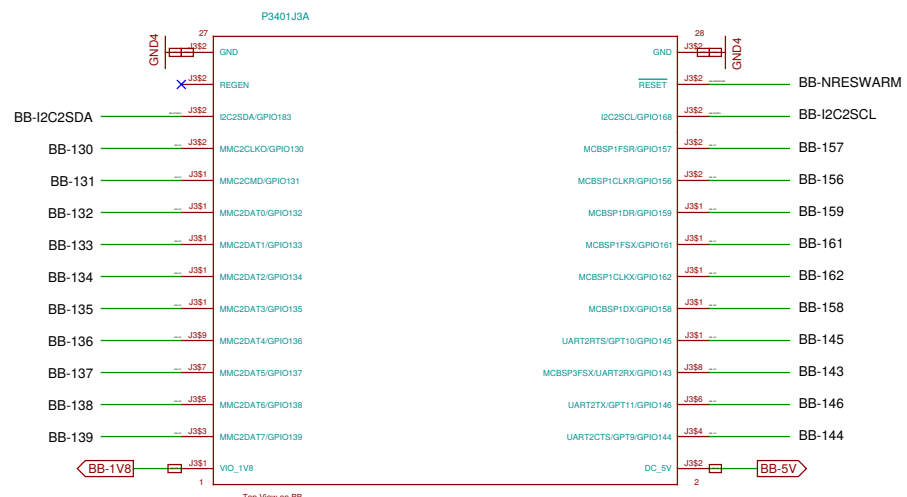
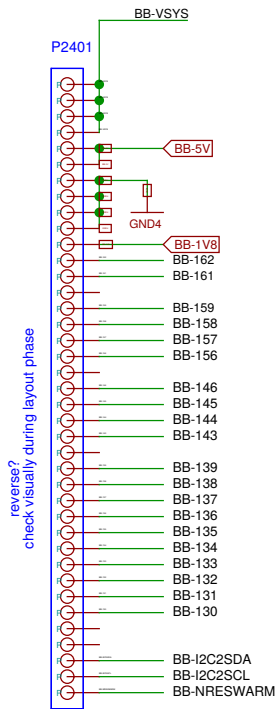

BB-xM Main Expansion Header (7.24)

TODO: needs decision on where to take this

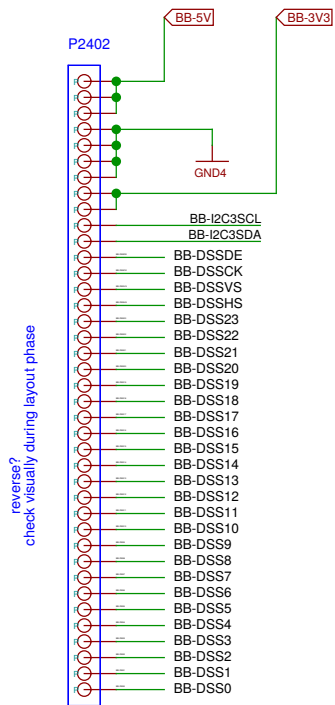

reverse?
check visually during layout phase

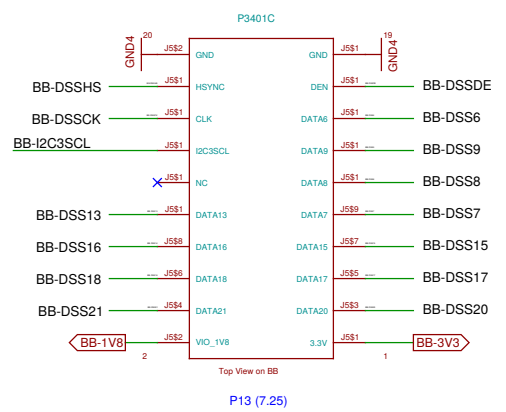
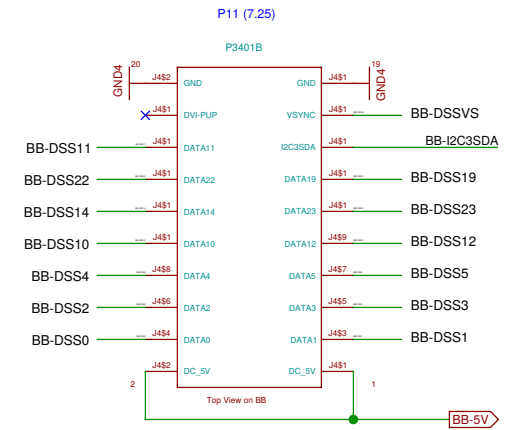

TODO: needs decision on where to take this

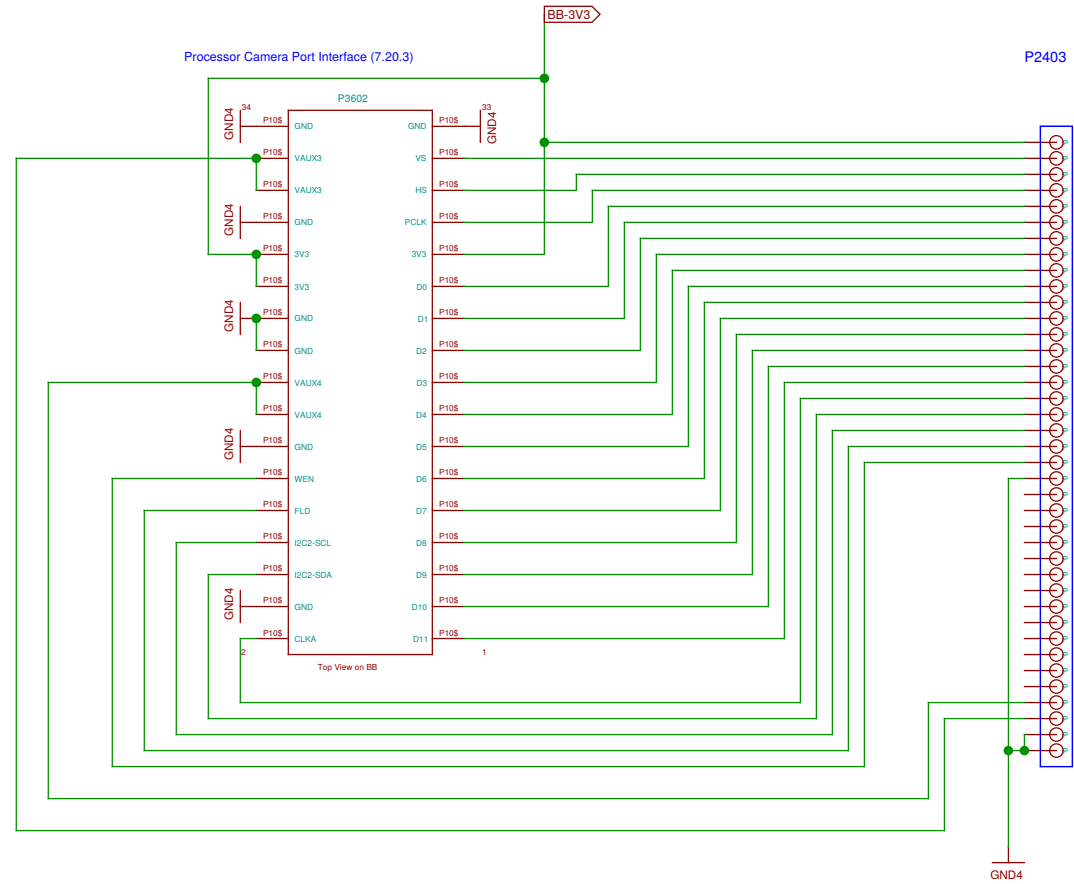

reverse?
check visually during layout phase

| | | |
|------------------------------|----------|-----------|
| Sheet: /BB-XM Adapter (CAM)/ | | |
| File: neo900_SS_36.sch | | |
| Title: BB-XM Adapter (CAM) | | |
| Size: %Z | Date: %D | Rev: %R |
| %K | | Id: 36/37 |

Molex Jumper cables to connect BB-XM-Adapter to Uppwer board

| | | |
|---------------------|---------------------|---------------------|
| N3701 15015-0439 | N3702 15015-0439 | N3703 15015-0439 |
| CPU | DISP | CAM |

| |
|-----------------------------|
| N3704 N900 case assembly |
|-----------------------------|

| |
|--------------------------|
| N3705 N97-CAMERA-HOLE |
|--------------------------|

| |
|-----------------------|
| N3706 headset jack |
|-----------------------|

| |
|----------------------|
| N3707 STENCIL-TOP |
|----------------------|

| |
|-------------------------|
| N3708 STENCIL-BOTTOM |
|-------------------------|

| | | |
|---|----------|-----------|
| Sheet: /No-Solder Components/ File: neo900_SS_37.sch | | |
| Title: No-Solder Components | | |
| Size: %Z | Date: %D | Rev: %R |
| %K | | Id: 37/37 |