

Click | Here

This sheet: [index](#)

[Sheet: OTG](#)
File: neo900_SS_2.sch
OTG & Switches

[Sheet: Charger/OTG-Booster](#)
File: neo900_SS_3.sch
Charger/OTG-Booster

[Sheet: Modem Power](#)
File: neo900_SS_4.sch
Modem Power

[Sheet: Fuel Gauge](#)
File: neo900_SS_5.sch
Fuel Gauge

[Sheet: 3G/4G Modem + SIM](#)
File: neo900_SS_6.sch
3G/4G Modem + SIM

[Sheet: Dual SIM switch](#)
File: neo900_SS_7.sch
Dual SIM switch

[Sheet: Antenna connections](#)
File: neo900_SS_8.sch
Antenna connections

[Sheet: WLAN, Bluetooth, FM](#)
File: neo900_SS_9.sch
WLAN, Bluetooth, FM

[Sheet: Sensors](#)
File: neo900_SS_10.sch
Sensors

[Sheet: Audio Codec](#)
File: neo900_SS_11.sch
Audio Codec

[Sheet: Audio Headset + Mic](#)
File: neo900_SS_12.sch
Audio Headset + Mic

[Sheet: ECI](#)
File: neo900_SS_13.sch
ECI

[Sheet: Audio Handsfree](#)
File: neo900_SS_14.sch
Audio Handsfree

[Sheet: Misc \(lower\)](#)
File: neo900_SS_15.sch
Misc (lower)

[Sheet: RFID/NFC Reader](#)
File: neo900_SS_16.sch
RFID/NFC Reader

[Sheet: RFID/NFC Controller](#)
File: neo900_SS_17.sch
RFID/NFC Controller

[Sheet: Hackerbus](#)
File: neo900_SS_18.sch
Hackerbus

[Sheet: Infrared](#)
File: neo900_SS_19.sch
Infrared

[Sheet: B2B to UPPER](#)
File: neo900_SS_20.sch
B2B to UPPER

[Sheet: uSD Breakout Board](#)
File: neo900_SS_21.sch
uSD Breakout Board

[Sheet: B2B to LOWER](#)
File: neo900_SS_22.sch
B2B to LOWER

[Sheet: Keypad](#)
File: neo900_SS_23.sch
Keypad

[Sheet: Display-Peripherals](#)
File: neo900_SS_24.sch
Display-Peripherals

[Sheet: Display-Panel&Power](#)
File: neo900_SS_25.sch
Display-Panel&Power

Click | Here

[Sheet: CPU + PoP RAM/NAND](#)
File: neo900_SS_26.sch
CPU + PoP RAM/NAND

[Sheet: eMMC](#)
File: neo900_SS_27.sch
eMMC

[Sheet: PMU+Codec](#)
File: neo900_SS_28.sch
PMU+Codec

[Sheet: BB-XM Dummy \(TWL4030\)](#)
File: neo900_SS_29.sch
BB-XM Dummy (TWL4030)

[Sheet: Camera](#)
File: neo900_SS_30.sch
Camera

[Sheet: LEDs](#)
File: neo900_SS_31.sch
LEDs

[Sheet: Fancy LEDs](#)
File: neo900_SS_32.sch
Fancy LEDs

[Sheet: Connector to BB-XM](#)
File: neo900_SS_33.sch
Connector to BB-XM

[Sheet: BB-XM Adapter \(CPU\)](#)
File: neo900_SS_34.sch
BB-XM Adapter (CPU)

[Sheet: BB-XM Adapter \(DISP\)](#)
File: neo900_SS_35.sch
BB-XM Adapter (DISP)

[Sheet: BB-XM Adapter \(CAM\)](#)
File: neo900_SS_36.sch
BB-XM Adapter (CAM)

[Sheet: No-Solder Components](#)
File: neo900_SS_37.sch
No-Solder Components

Note regarding I2C addresses:
Addresses in the schematics are provided for convenience.
The authoritative source is
<https://neo900.org/git?p=misc;a=tree;f=i2c>

Sheet: /		
File: neo900.sch		
Title: Neo900		
Size: A3	Date: 16 JUL 2016	Rev:
Plotted by eeshow b830190 - 20160924-19:35Z		Id: 1/37

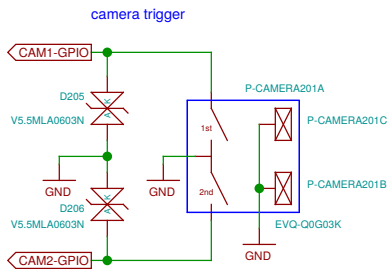
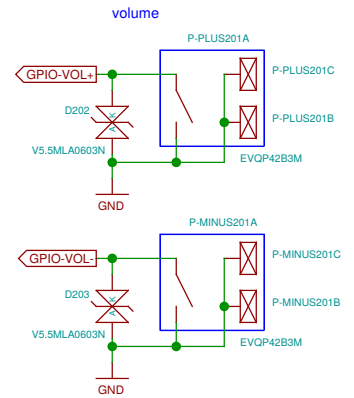
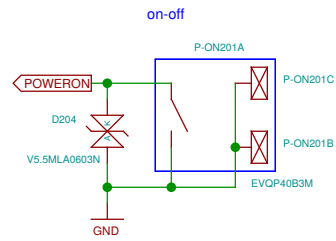
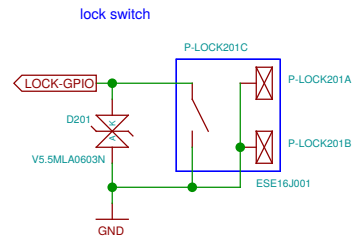

can be used to test/operate the modem through the OTG port (w/o UPPER PCB)

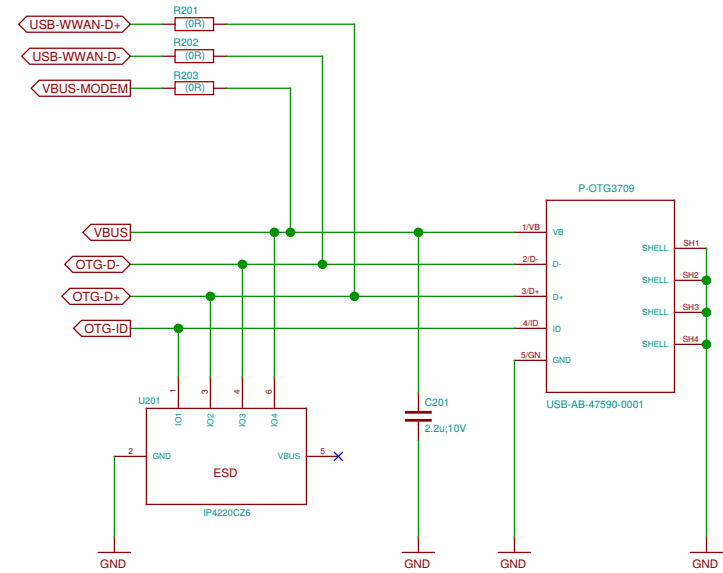

place in scan matrix? would need 3-4 wires to UPPER board instead of 2

in any case it is sufficient to connect GPIO-VOL+ and VOL- to two pins on the B2B connector

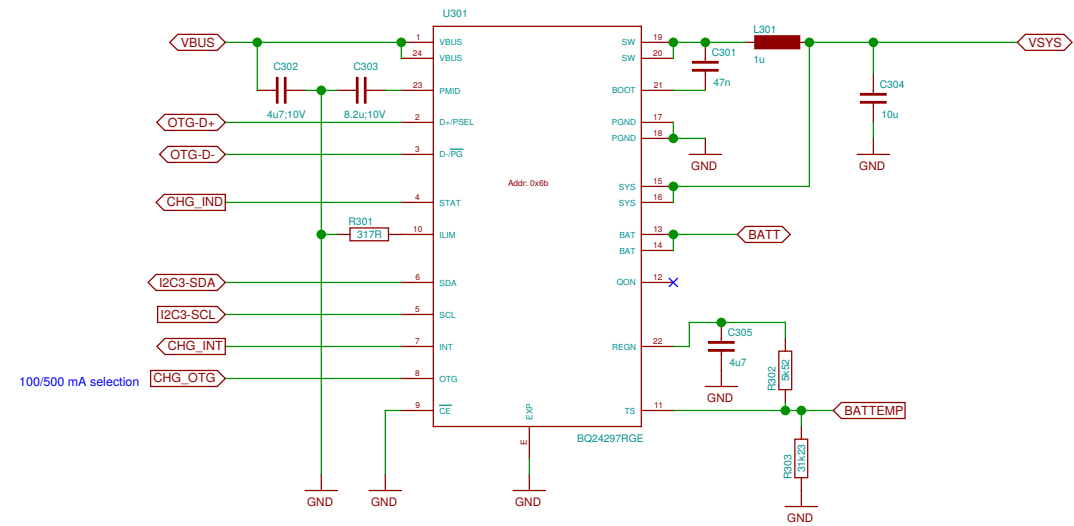

Sheet: /Charger/OTG-Booster/		
File: neo900_SS_3.sch		
Title: Charger/OTG-Booster		
Size: A3	Date: 17 JUL 2016	Rev:
Plotted by eeshow b830190- 20160924-19:35Z		Id: 3/37

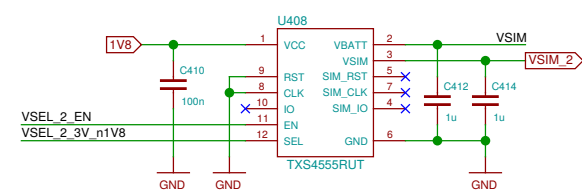
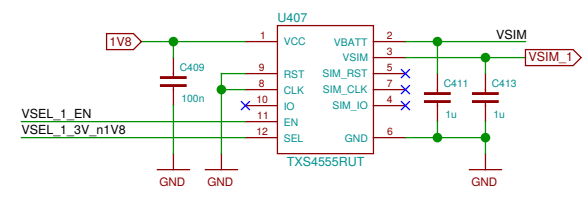
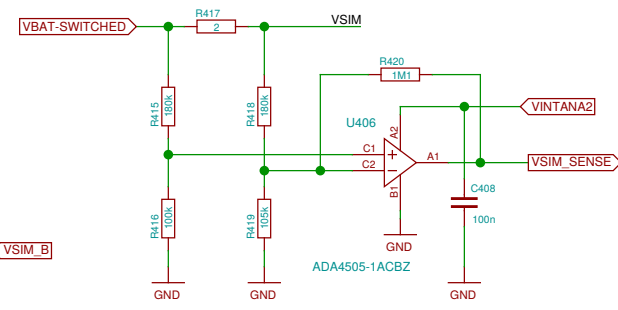
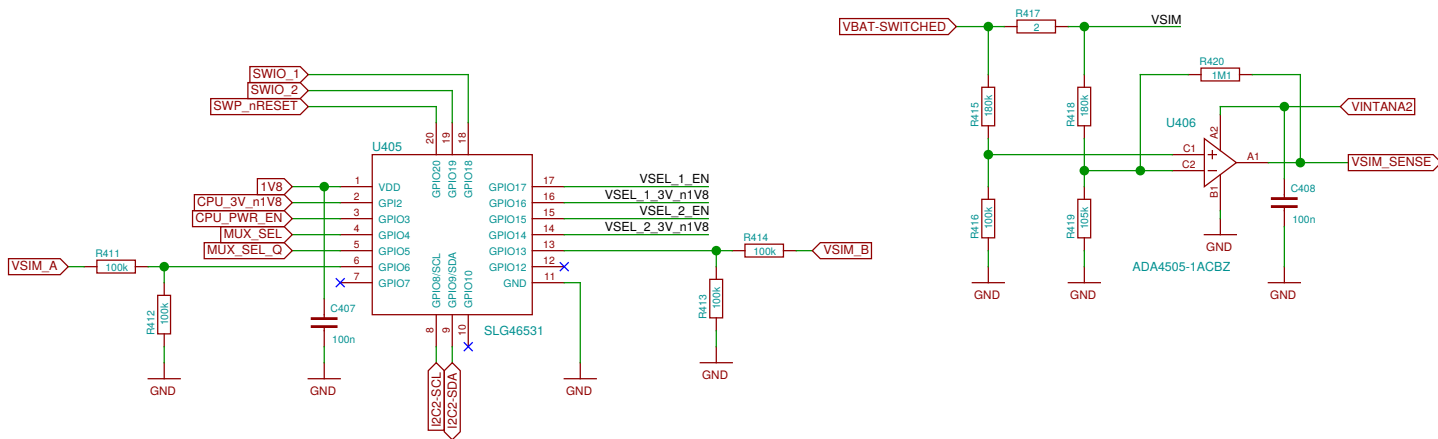
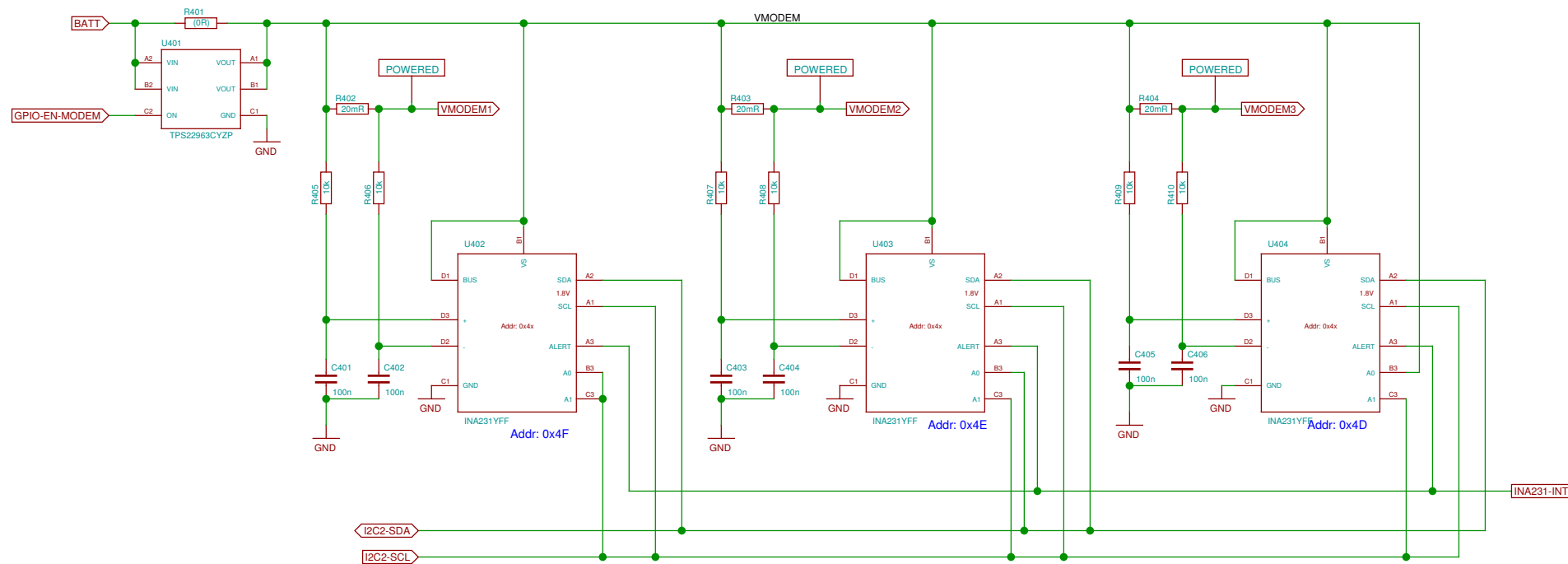

TODO: update SLG design for changed pins

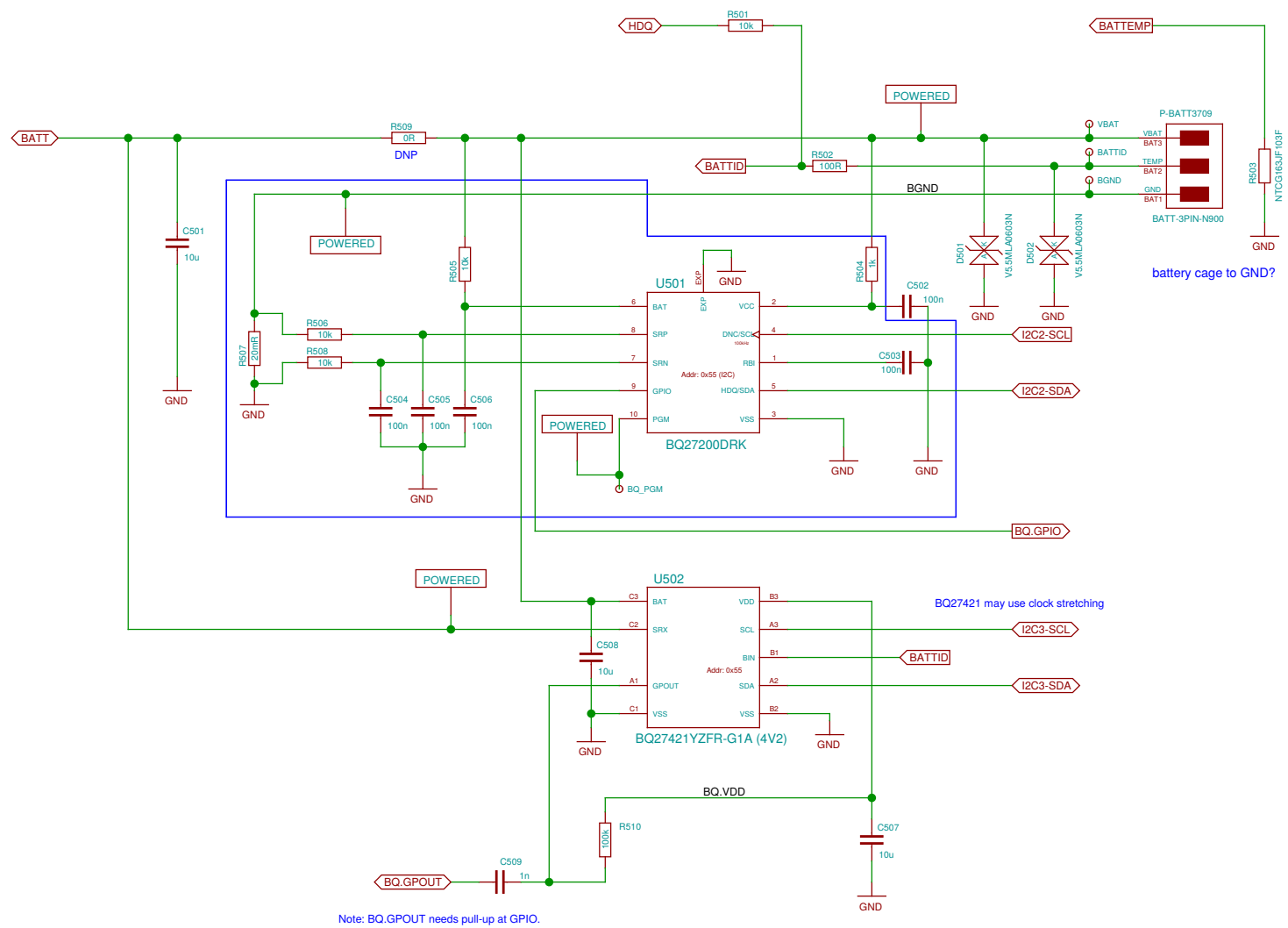

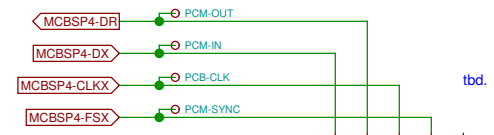
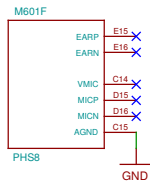

- ◁ VSIM_B ▷ ✕
- ◁ MODEM_RST_B ▷ ✕
- ◁ MODEM_DATA_B ▷ ✕
- ◁ MODEM_CLK_B ▷ ✕
- ◁ MODEM_CD_B ▷ ✕

TODO: B-SIM bus FFS

- ◁ VSIM_A ▷ K15
- ◁ MODEM_RST_A ▷ L14
- ◁ MODEM_DATA_A ▷ K14
- ◁ MODEM_CLK_A ▷ L15
- ◁ MODEM_CD_A ▷ M14

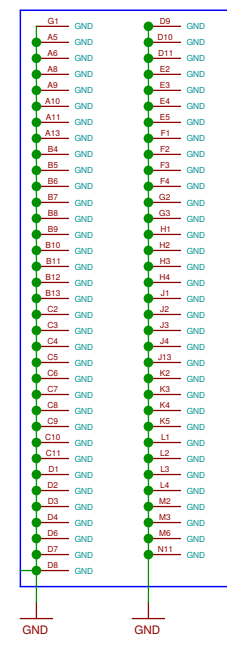
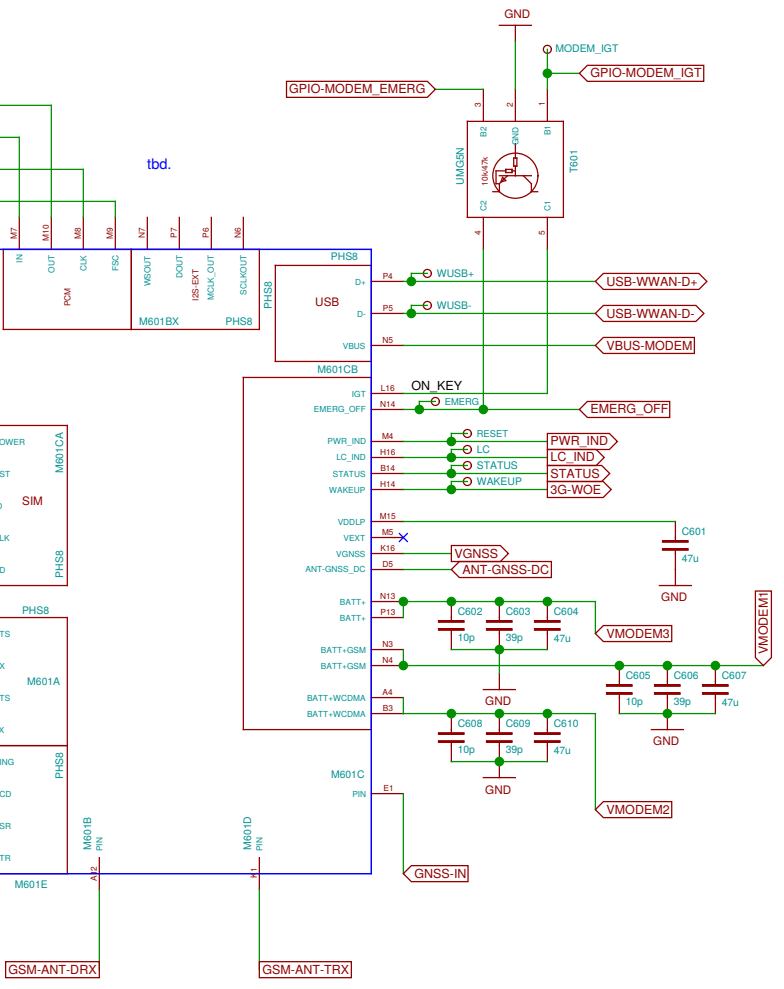
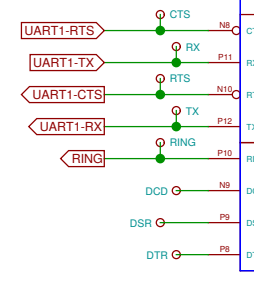

TODO: shield connection near D8

Can we connect UART in parallel to Bluetooth UART (i.e. if BT is disabled we can unbrick the Modem?)

Note: MODEM_CD_* (CCIN) is 1.8 V compatible.

Small logic gates are placed in close vicinity and share the bypass capacitor.

The FSA2866s operate at 3.3 V, for compatibility with Class B (2.7-3.3 V). The control inputs nOE and SEL are still 1.8 V compatible.

The delay timing is approximative. NXP provide the following formula: $t_w = K * R * C = \text{approx. } 500 \text{ ms}$ for K estimated to be 0.5.

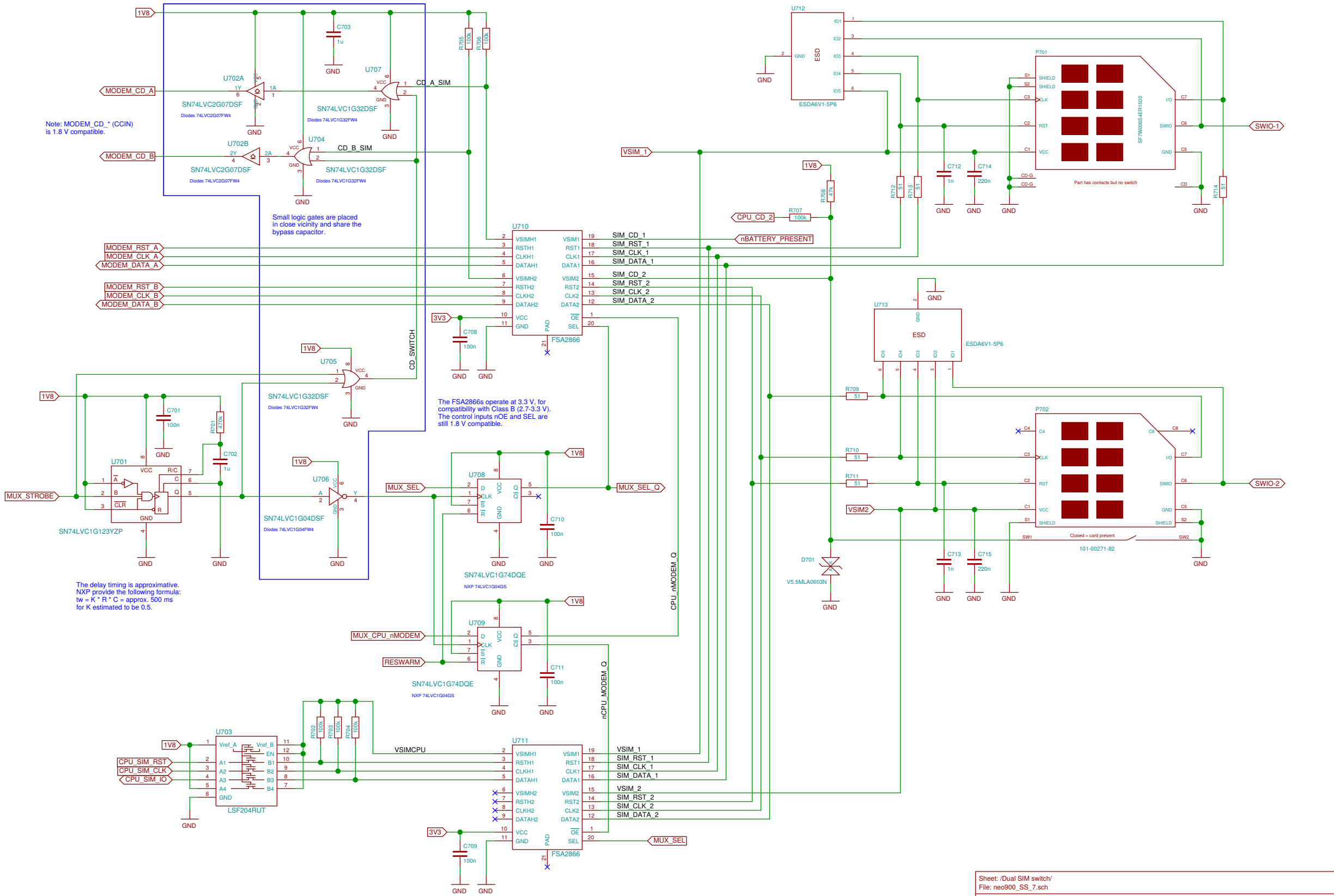

Sheet: /Dual SIM switch/		File: neo900_SS_7.sch	
Title: Dual SIM switch			
Size: A3	Date: 17 JUL 2016	Rev:	
Plotted by eeshow b830190 - 20160924-19.35Z		Id: 7/37	

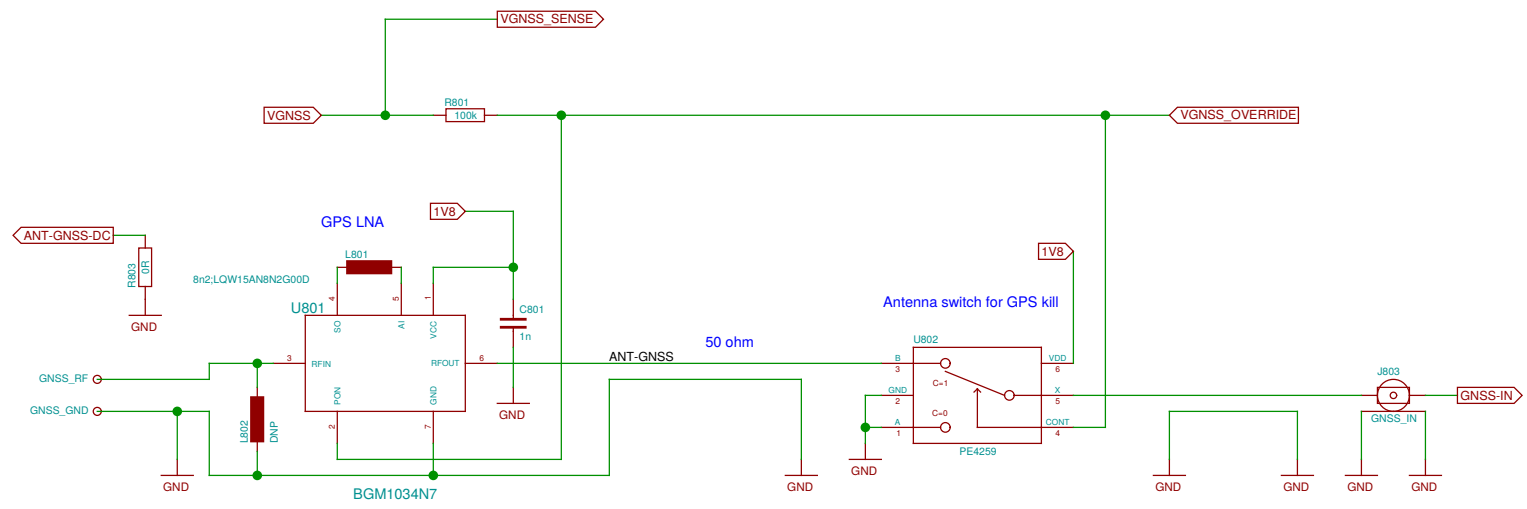

TODO: connect DRX to FM ?

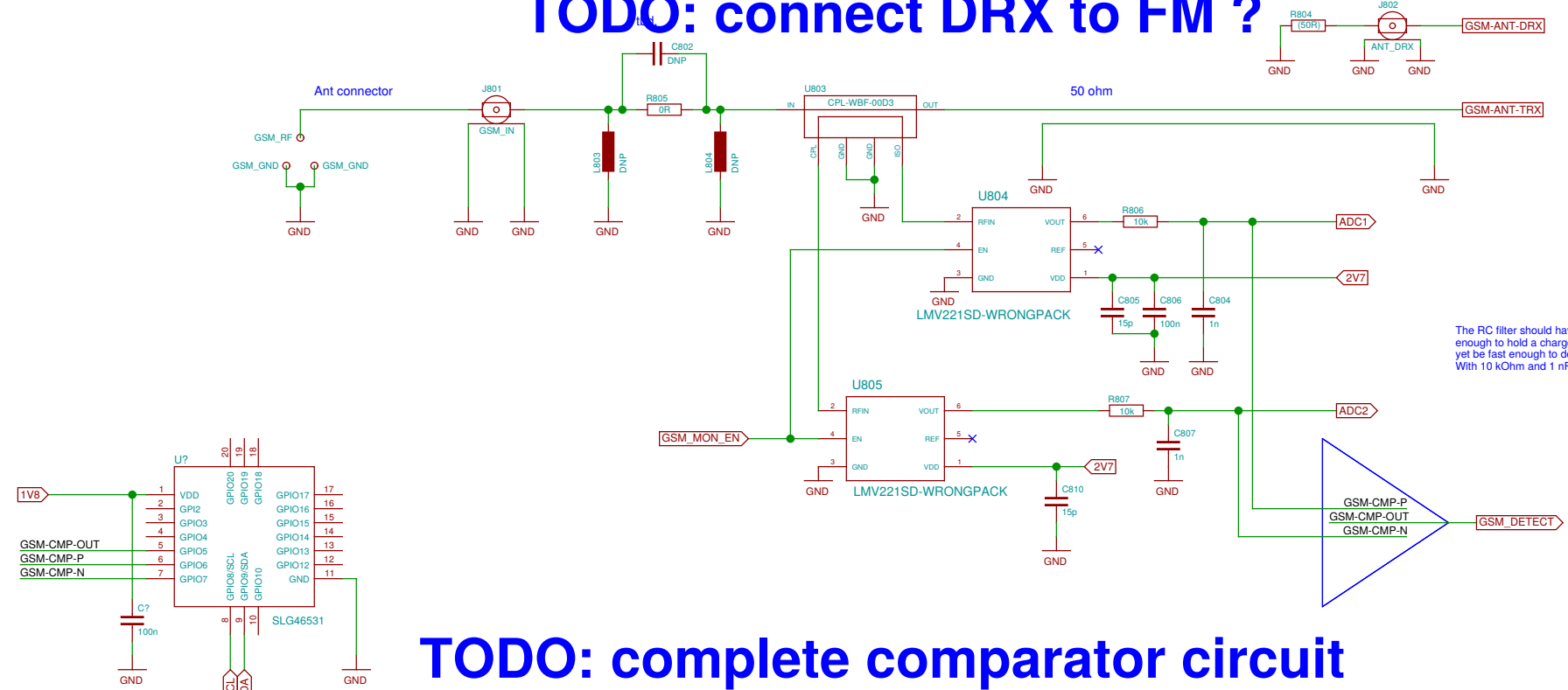

The RC filter should have C large enough enough to hold a charge in pulsed operation, yet be fast enough to detect short activity. With 10 kOhm and 1 nF, we get about 16 kHz.

TODO: complete comparator circuit
TODO: add silego i2c assignment
TODO: iox

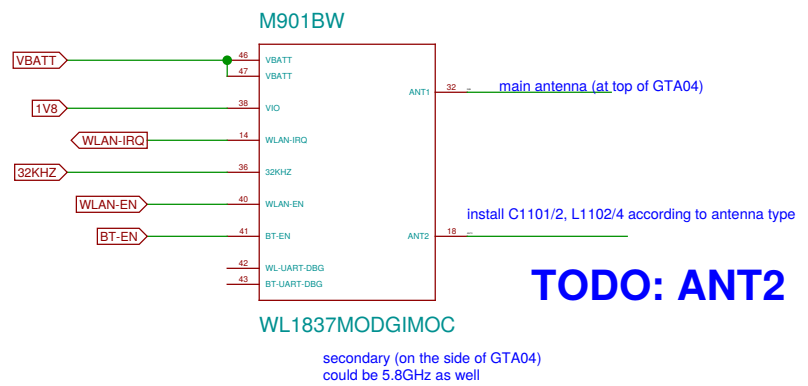

TODO: ANT2

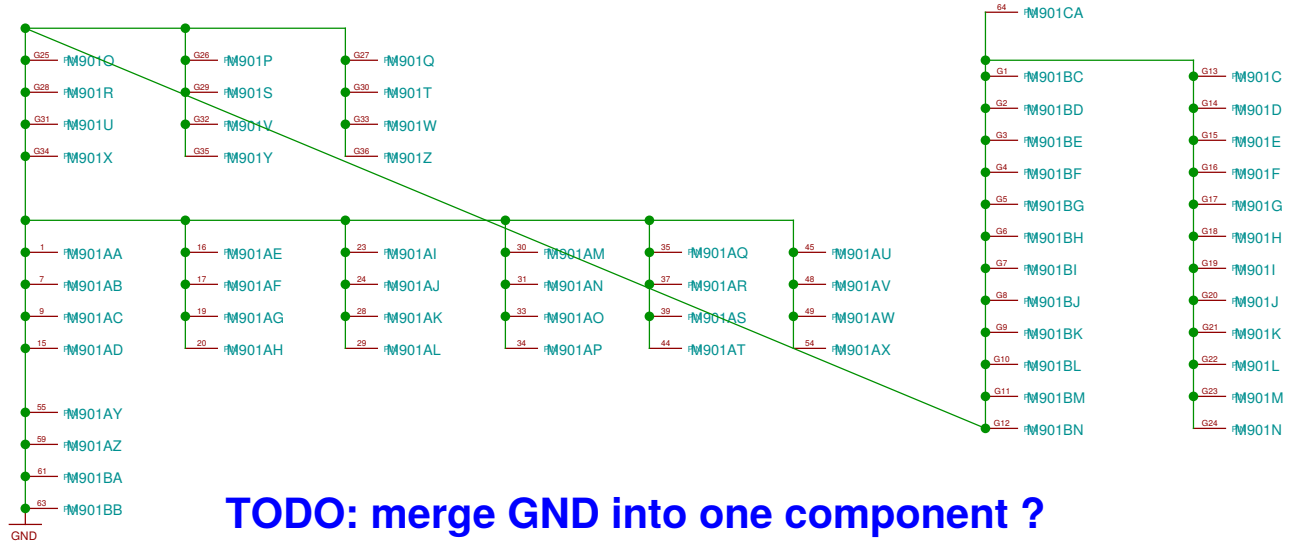

TODO: merge GND into one component ?

TODO: unfinished

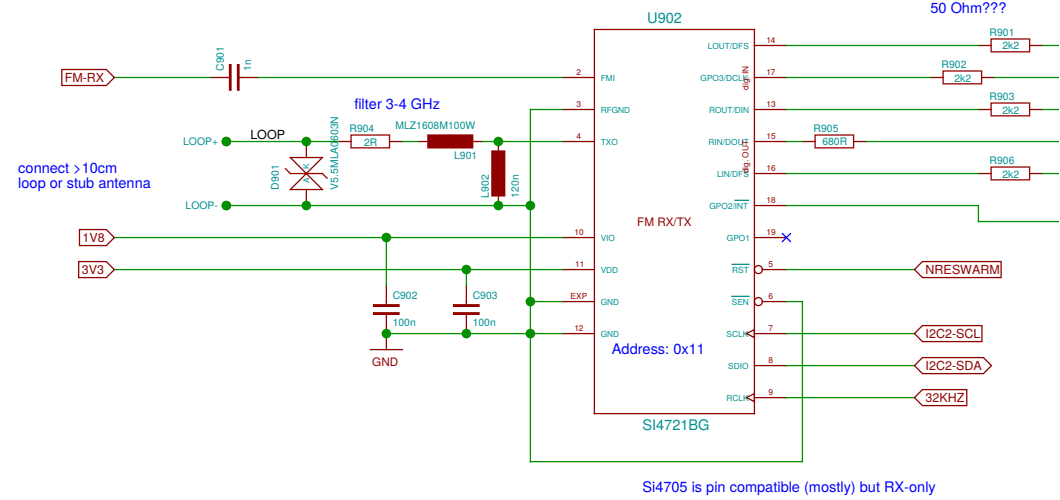
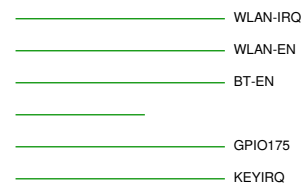
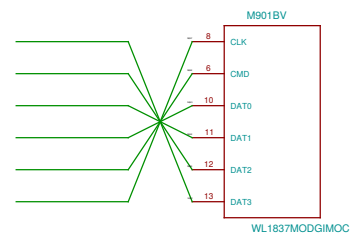
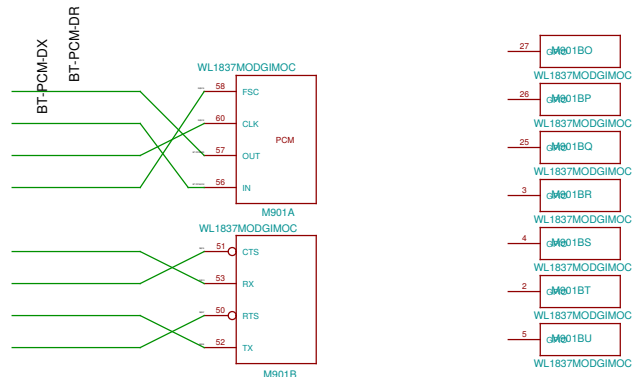

Si4705 is pin compatible (mostly) but RX-only

TODO: unfinished

- FSX
- CLKX
- DX
- DR
- FSR
- CLKR

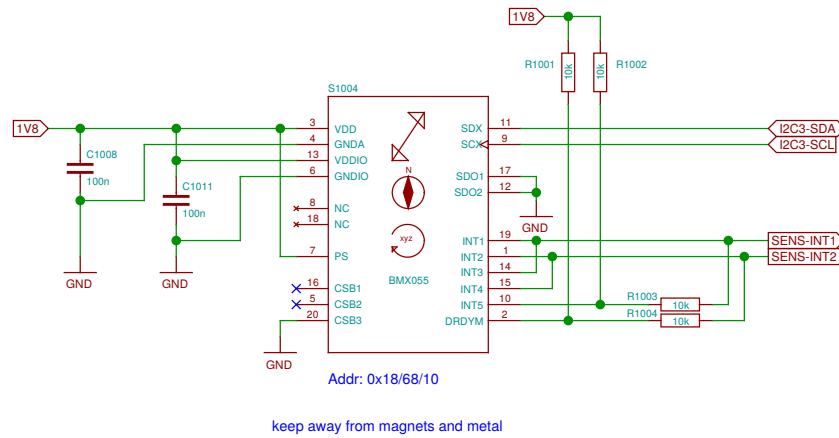
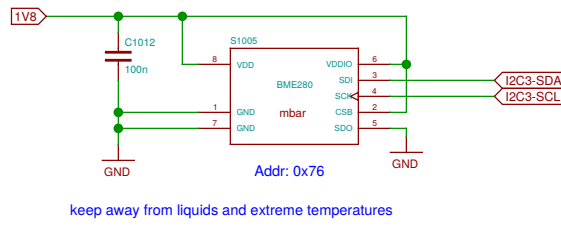
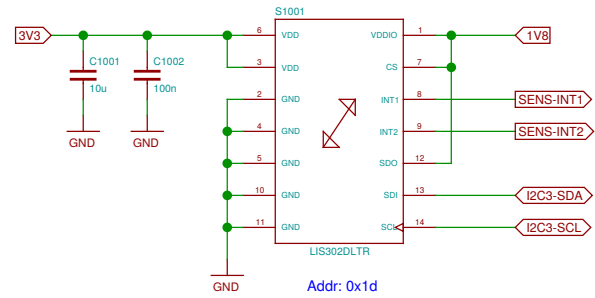

Sheet: /Sensors/ File: neo900_SS_10.sch		
Title: Sensors		
Size: A3	Date: 17 JUL 2016	Rev:
Plotted by eeshow b830190 - 20160924-19:35Z		Id: 10/37

problem: this is a 0.5mm BGA making lower board expensive
 but it appears to be not extremely critical (only 3 rows and inner ring is GND)
 problem: analog mic is on upper board
 alternative: place on upper board (to be evaluated)

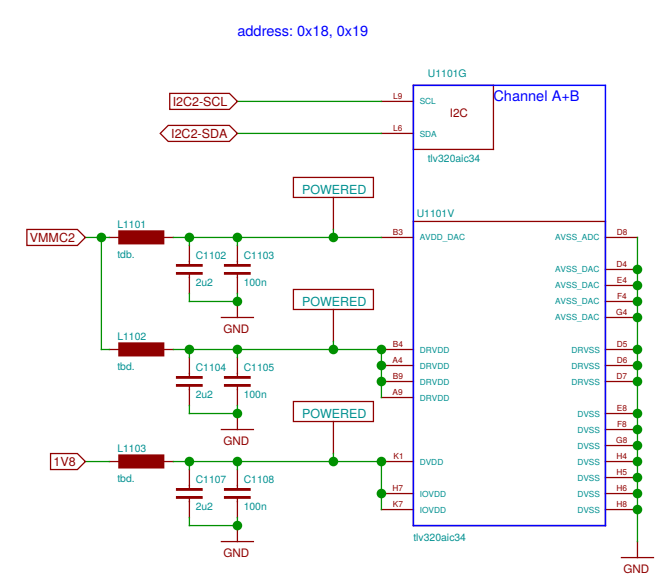
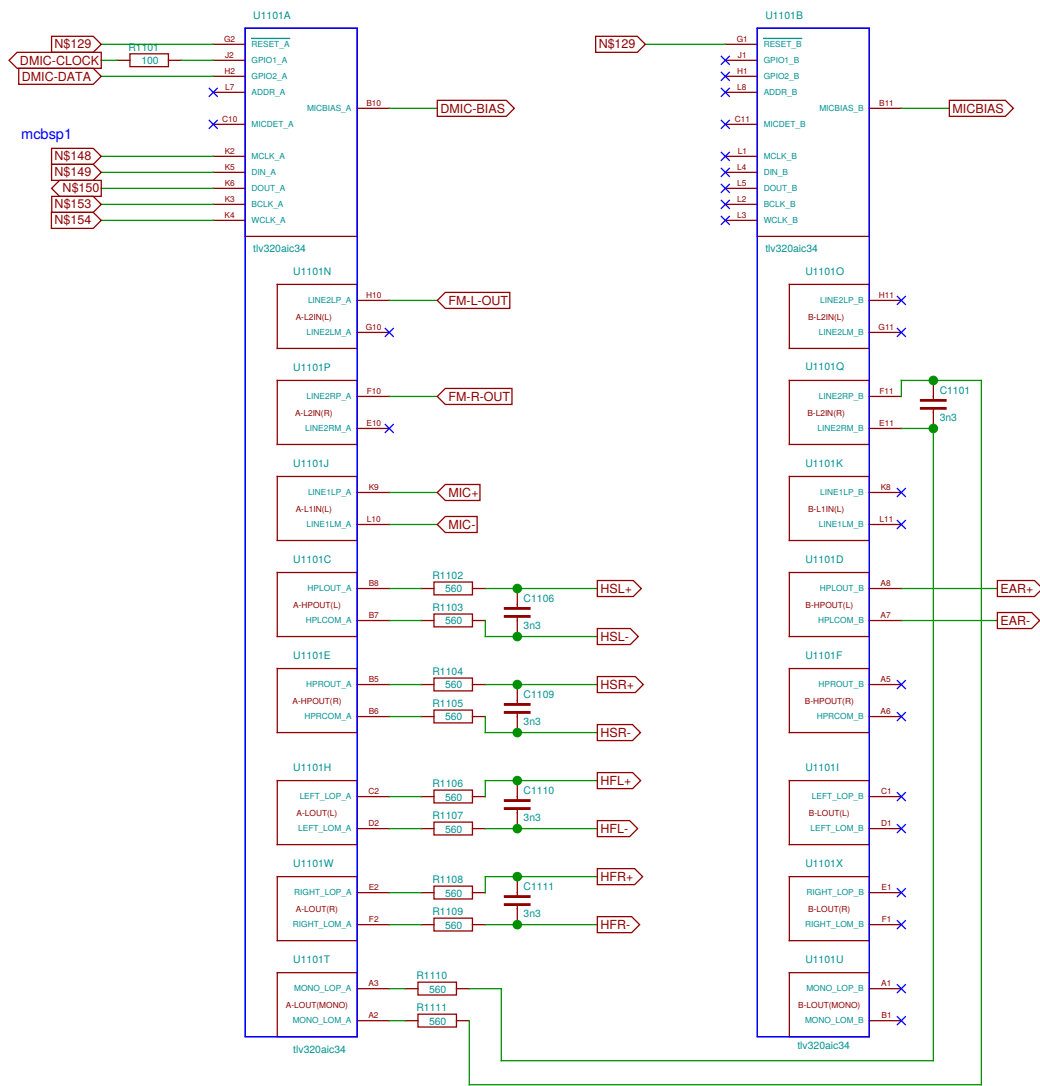

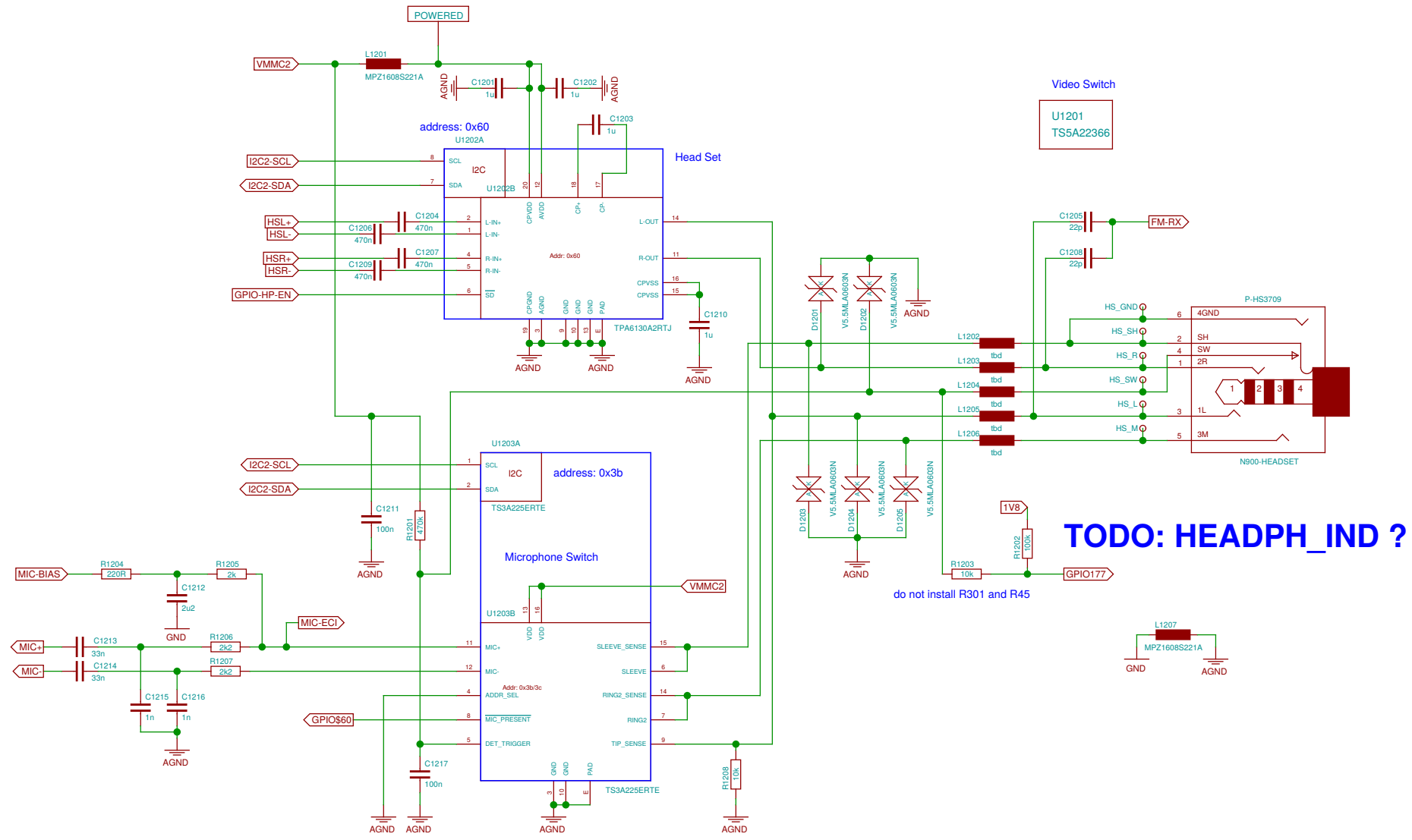

Video Switch
U1201
TS5A22366

TODO: HEADPH_IND ?

do not install R301 and R45

Sheet: /Audio Headset + Mic/		Date: 17 JUL 2016	
File: neo900_SS_12.sch		Rev:	
Title: Audio Headset + Mic		Id: 12/37	
Size: A3	Date: 17 JUL 2016	Rev:	
Plotted by eeshow b630190 - 20160924-19:35Z			

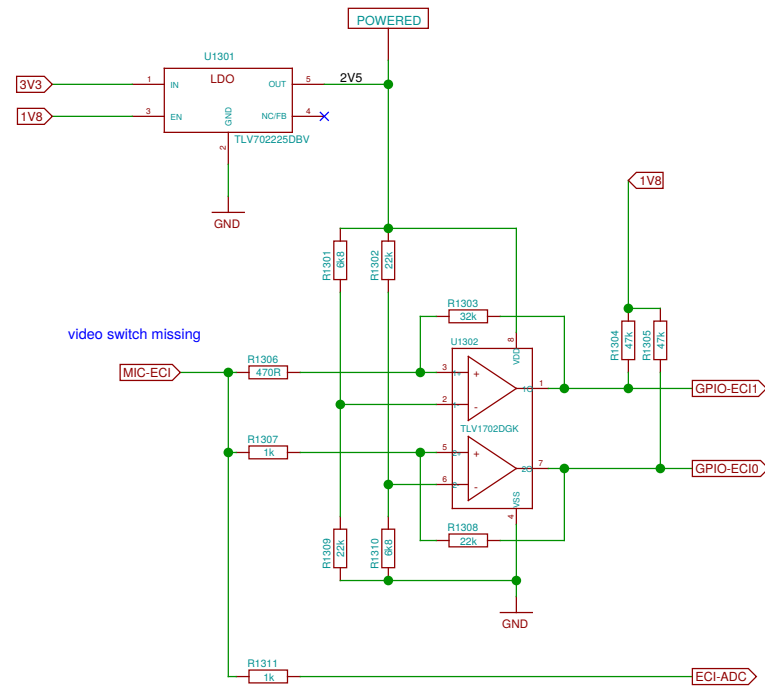

video switch missing

TODO: draw comparator right

Sheet: /ECI/		
File: neo900_SS_13.sch		
Title: ECI		
Size: A3	Date: 17 JUL 2016	Rev:
Plotted by eeshow b830190- 20160924-19:35Z		Id: 13/37

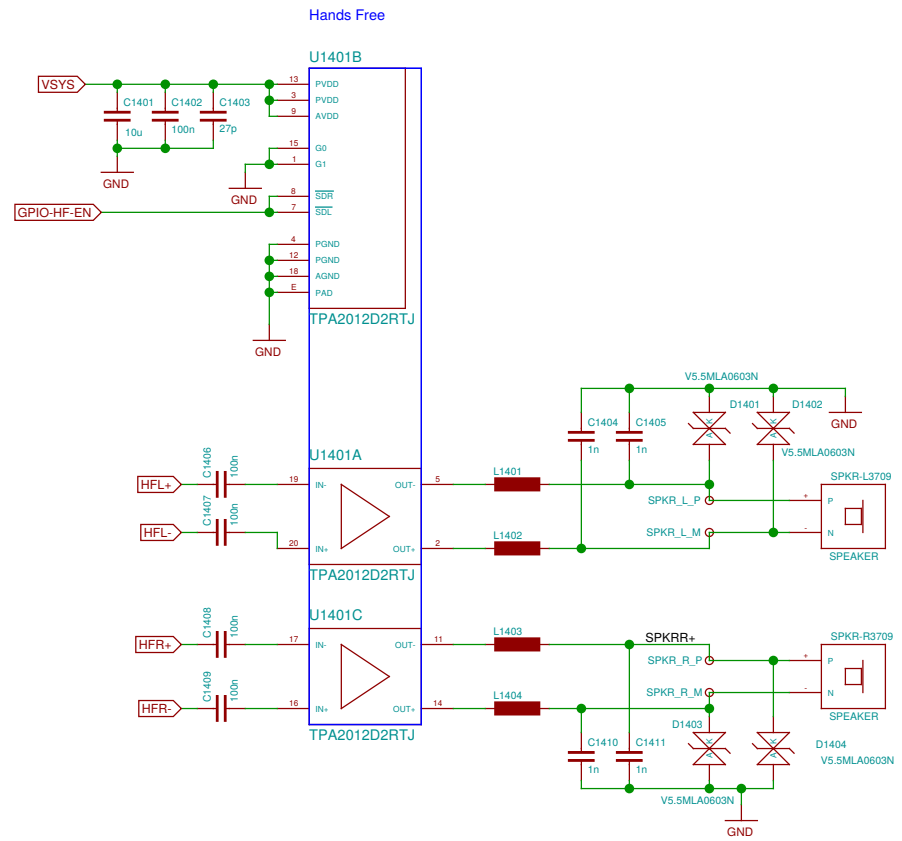

Sheet: /Audio Handsfree/ File: neo900_SS_14.sch		
Title: Audio Handsfree		
Size: A3	Date: 17 JUL 2016	Rev:
Plotted by eeshow b830190- 20160924-19.35Z		Id: 14/37

The LOWER-BOB interconnect is defined in the Hackerbus specification
<http://neo900.org/stuff/papers/hb.pdf>

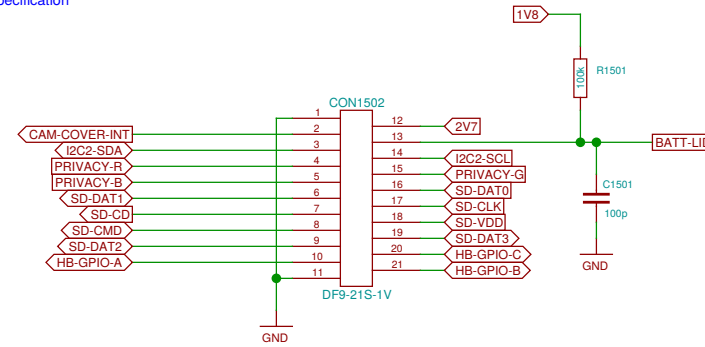
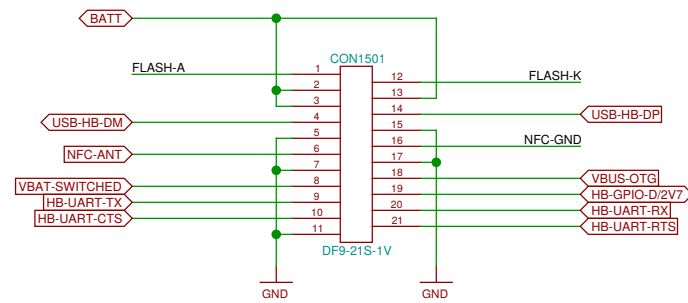

TODO: define NFC-GND

Vibramotor

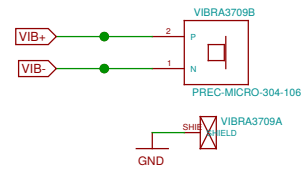

Shield

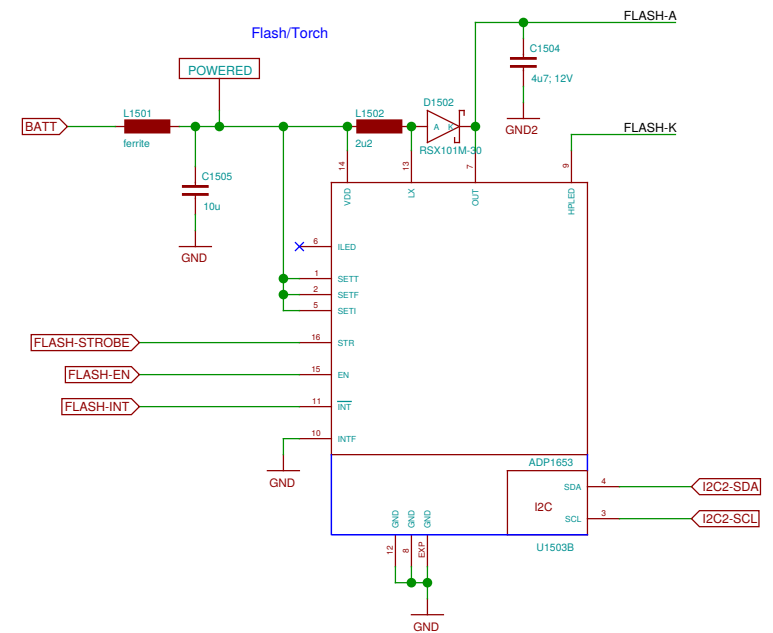
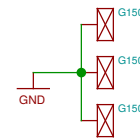

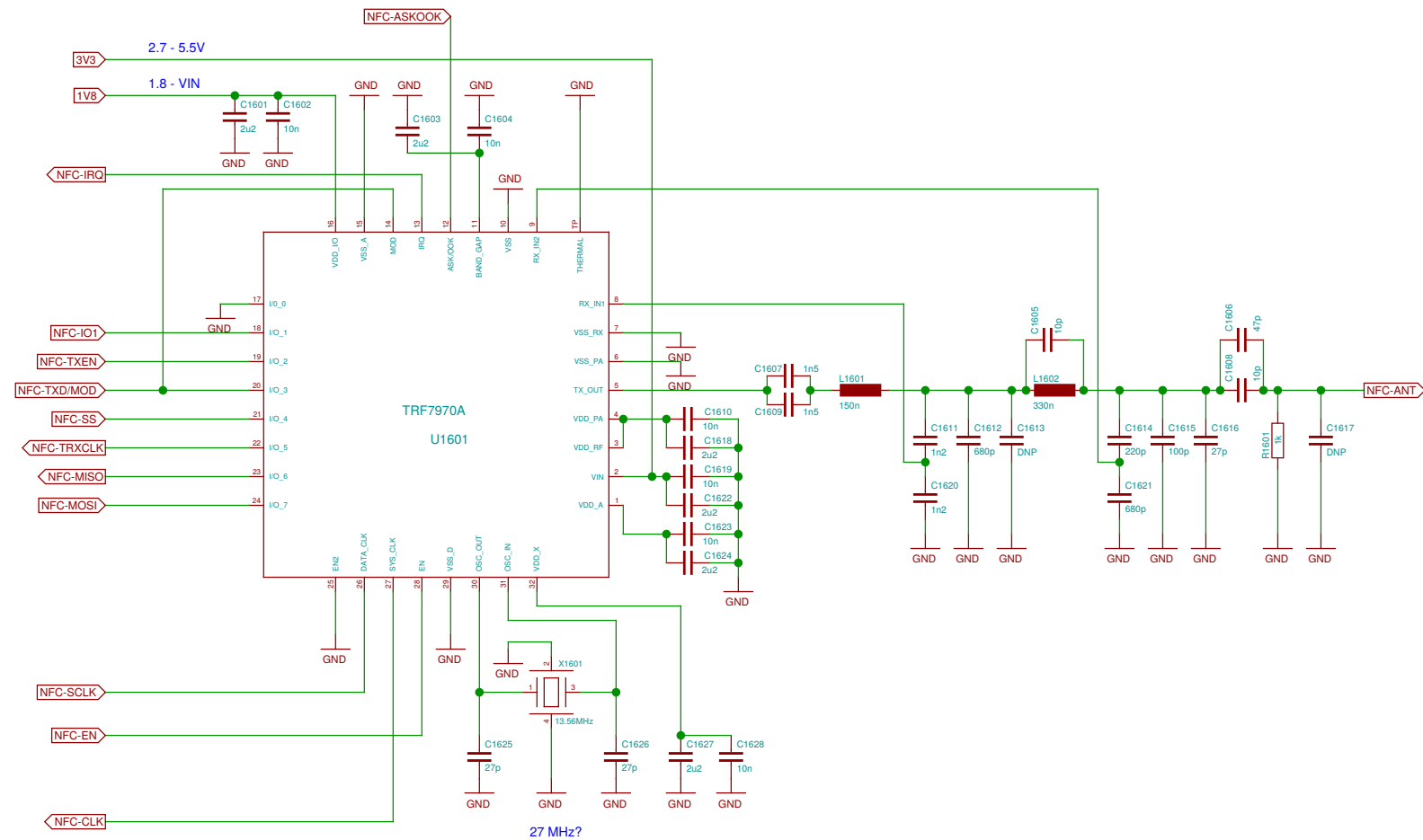

NOTE: this is mangling up Breakout and Lower board connectors
Signals may have to be fed through the breakout board connector increasing resistance

TODO: align with HB WP

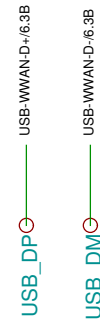

TODO: HB "base circuit" (level shifters, etc.) goes here

Missing 10 level shifter chip (or do we really have the space for 10x discrete T+R+D ca. 3x3mm each?)

Missing 6x 2R for alternate function select (do we have the space for ca. 2.5 x 5mm?)

Sheet: /Hackerbus/ File: neo900_SS_18.sch		
Title: Hackerbus		
Size: A3	Date: 17 JUL 2016	Rev:
Plotted by eeshow b830190+ 20160924-19:35Z		Id: 18/37

TODO: update D1901 footprint

NOTE: 1V8 may be quite noisy

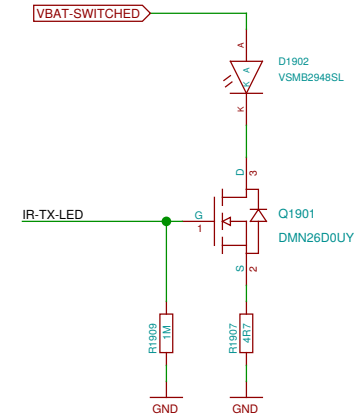
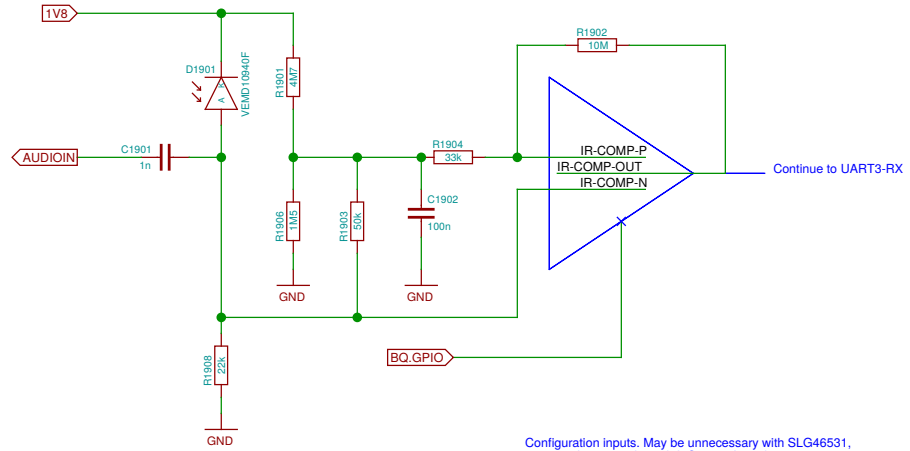

Configuration inputs. May be unnecessary with SLG46531, once configuration through I2C is confirmed.

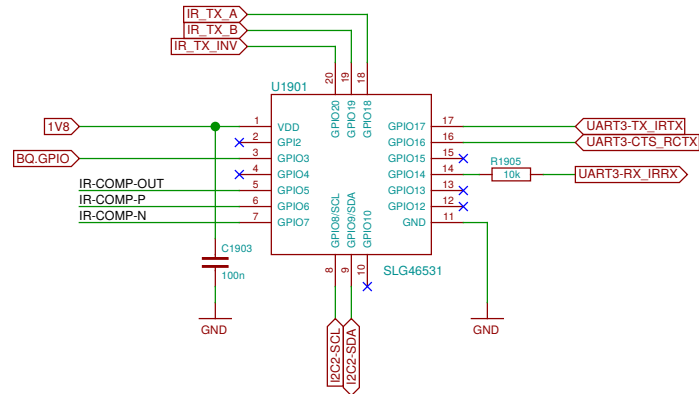

TODO: update when details settle

ca. 130 signals (to be counted exactly after definition of upper/lower split)

- MMCS-DATA1/9.1A
- MMCS-DATA2/9.1A
- MMCS-DATA3/9.1A
- GPIO-WLAN-IRQ/9.1A
- GPIO-BT-EN/9.1C
- UART1-RX/9.1C
- UART1-RTS/9.1C
- UART1-CTS/9.1D
- UART1-TX/9.1D
- MCBSP3-FCK/9.1D
- MCBSP3-CLK/9.1D
- MCBSP3-DR/9.1D
- MCBSP3-DX/9.1D
- SYSCLK/9.3C
- 32KHZ/9.4A
- GPIO-FM-EN/9.3A
- GPIO-FMIRQ/9.3A
- MCBSP2-FCK/9.3A
- MCBSP2-CLK/9.3A
- MCBSP2-DR/9.3A
- MCBSP2-DX/9.3A
- GPIN115/10.3B
- GPIO56/10.3A
- GPIO51/10.3B
- GPIO55/10.4A
- GPIO56/10.4A
- ACCEL-INT/10.4C
- NS129/11.2A
- NS148/11.1A
- NS149/11.1A
- NS150/11.1A
- NS153/11.1A
- NS154/11.1A
- GPIO-ECI1/13.3B
- GPIO-ECI0/13.3C
- ECI-ADC/13.3C
- VMMC2/12.1A
- GPIO-HP-EN/12.1B
- GPIO560/12.2D
- GPIO177/12.4C
- GPIO-HF-EN/14.1B
- GPIO-FLASH-STR/15.1A
- GPIO-FLASH-EN/15.1A
- GPIO-FLASH-INT/15.1A
- GPIO-BATT-LID/15.1B
- SD-CMD/15.2A
- SD-CLK/15.2A
- SD-CD/15.2B
- SD-VDD/15.2A
- SD-DAT0/15.2B
- SD-DAT1/15.2B
- SD-DAT2/15.2A
- SD-DAT3/15.2A
- VIB+/15.1D
- VIB-/15.1D
- 3V3/19.1D
- 2V5/13.3B
- 1V8/19.1D
- VBUS/18.1C
- OTG-D-/3.1B
- OTG-D+/3.1B
- OTG-ID/2.2B
- VBUS-MODEM/6.3B
- USB-WWAN-D+/18.3A
- USB-WWAN-D-/18.3A
- 2V7/8.4C
- GPIO-CAM-COVER/15.1B
- NS38
- LOCK-GPIO/1.2A
- POWERON/1.3A
- GPIO-VOL+/1.2B
- GPIO-VOL-/1.2B
- CAM1-GPIO/1.3B
- CAM2-GPIO/1.3C
- I2C3-SDA/10.4C
- I2C3-SCL/10.4C
- CHG_IND/3.1B
- NS131/3.1C
- NS141/3.1C
- NS143/3.1C
- BATTEMP/5.4A
- GPIO-EN-MODEM/4.1A
- I2C2-SDA/15.1A
- I2C2-SCL/15.1A
- INA231-INT/4.4C
- HDO/5.2A
- GPIO570/8.3B
- GPIO5110/8.1D
- NS19/8.2D
- NS229/8.3C
- ADC5114/8.1C
- ADC1/8.4C
- ADC2/8.4C
- GPIO-COMPARATOR/8.4D
- MCBSP4-DR/6.2A
- MCBSP4-DX/6.2A
- MCBSP4-CLKX/6.2A
- MCBSP4-FSX/6.2A
- UART7-RTS/6.2C
- UART7-CTS/6.2C
- UART7-RX/6.2C
- UART7-TX/6.2C
- RING/6.2C
- GPIO-MODEM_IGT/6.3A
- GPIO-MODEM_EMERG/6.3A
- EMERG_OFF/6.3B
- PWR_IND/6.3B
- LC_IND/6.3B
- STATUS/6.3B
- 3G-WOE/6.3B
- GPIO52/8.4A
- GPIO-WLAN-EN/9.1A
- MMC3-CLK/9.1A
- MMC3-CMD/9.1A
- MMC3-DATA0/9.1A

Pin assignment must be optimized for final component placement
we might have to switch to 80 or 100 pin connectors

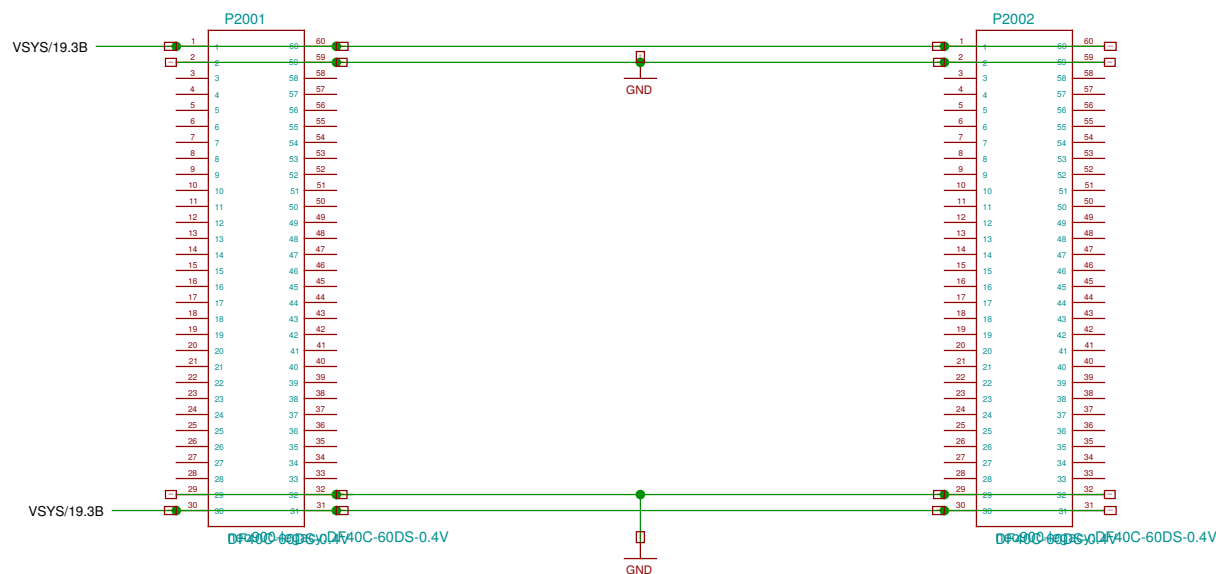

TODO: add ESD protection (here)

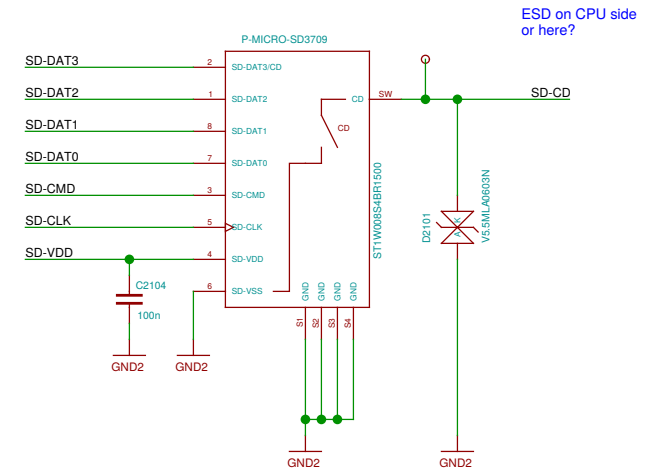
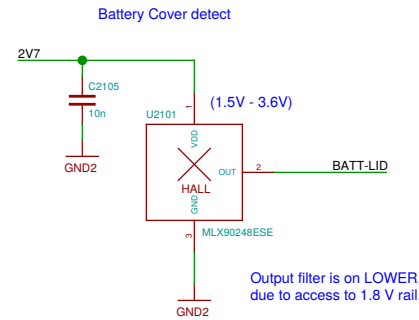
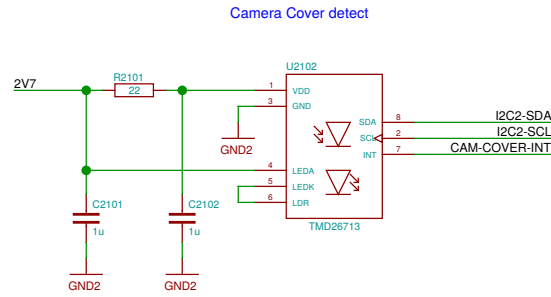

The LOWER_BOB interconnect is defined in the Hackabus specification
<http://neo900.org/stuff/papers/hb.pdf>

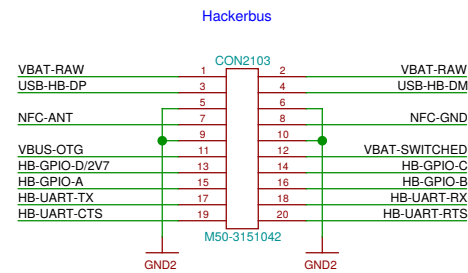
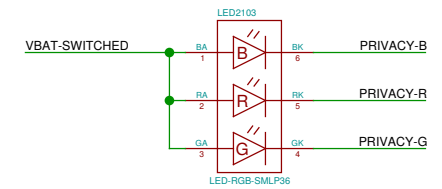
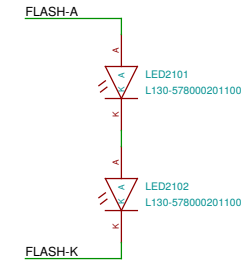
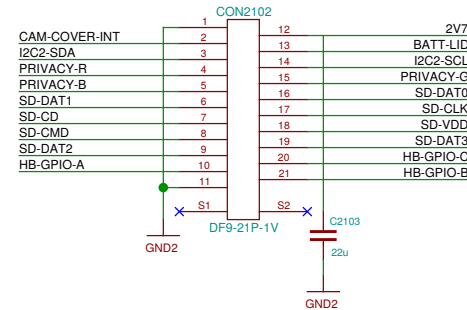
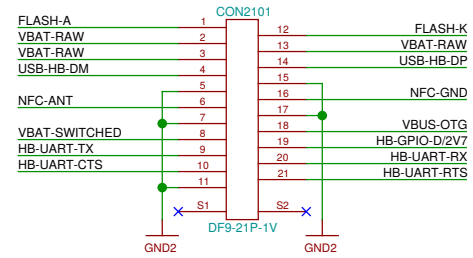

TODO: track B2B to UPPER



to be adjusted to lower board connector

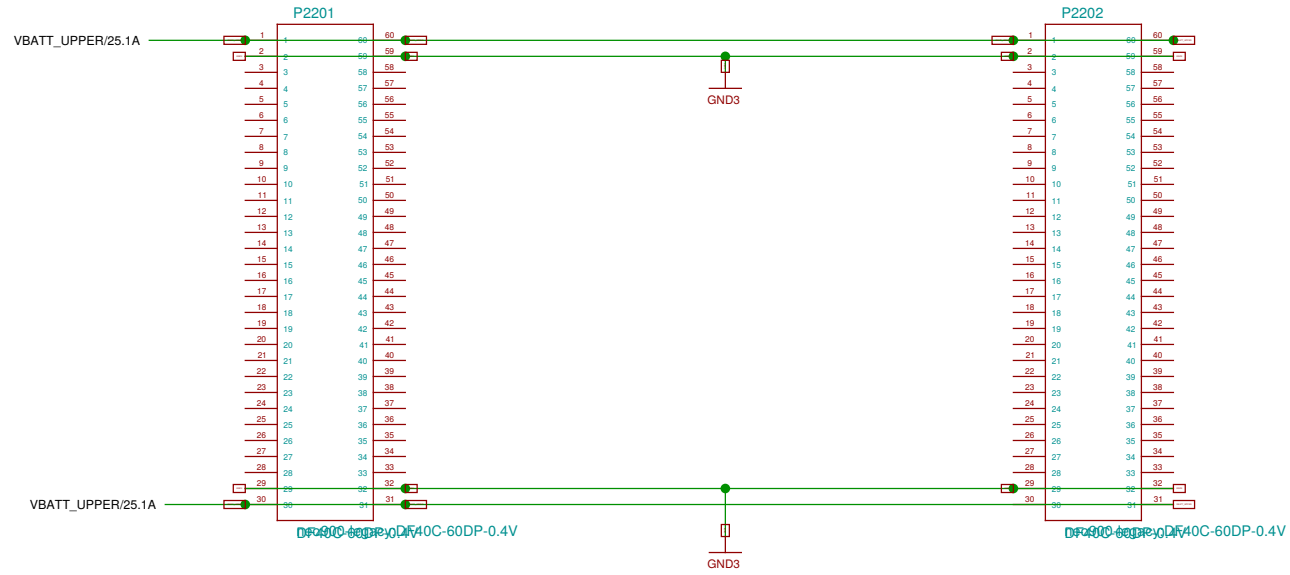

SHIELD

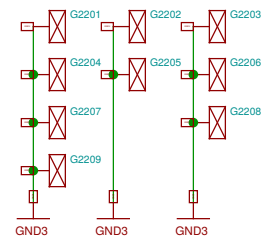

TODO: *_UPPER names ?

needs final tuning (which button on which position)
VOL+ and VOL- could drive FETs sitting in the matrix

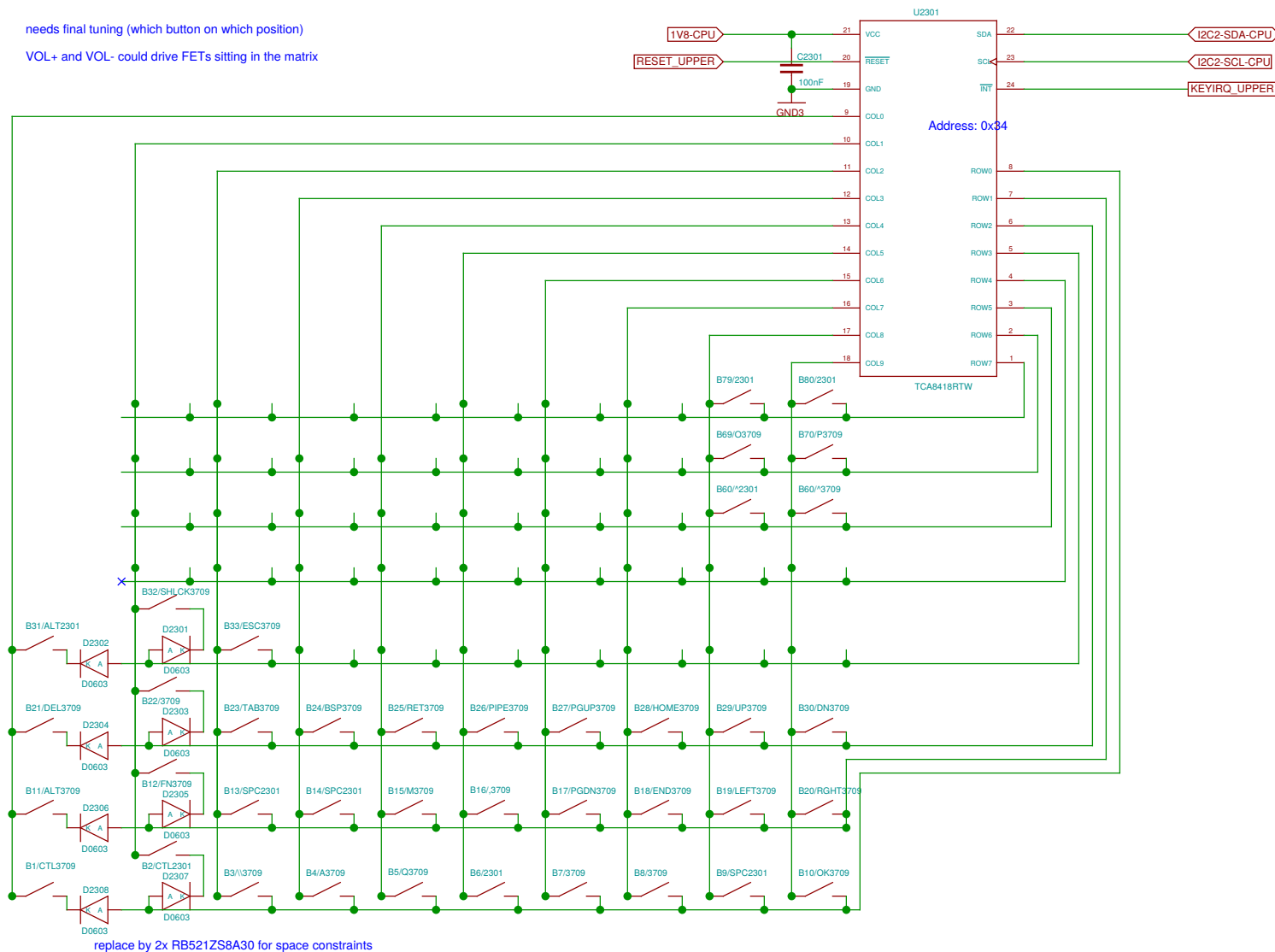

- TODO: remove 3709 in comp ref
- TODO: remove keycap from comp ref
- TODO: sort out 6 "ext" buttons
- TODO: rearrange matrix to avoid diodes ?

Resistive Touch (display connector)

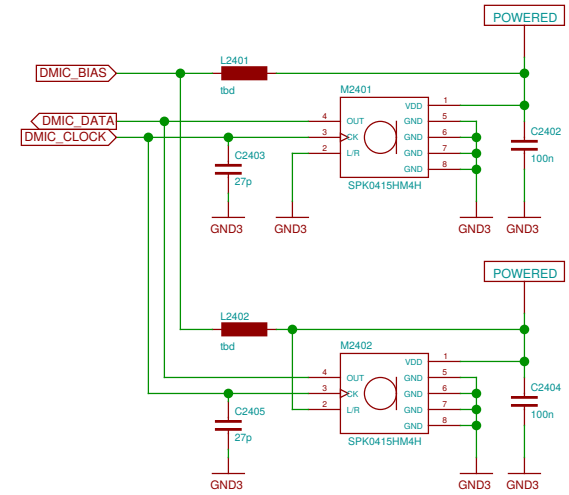
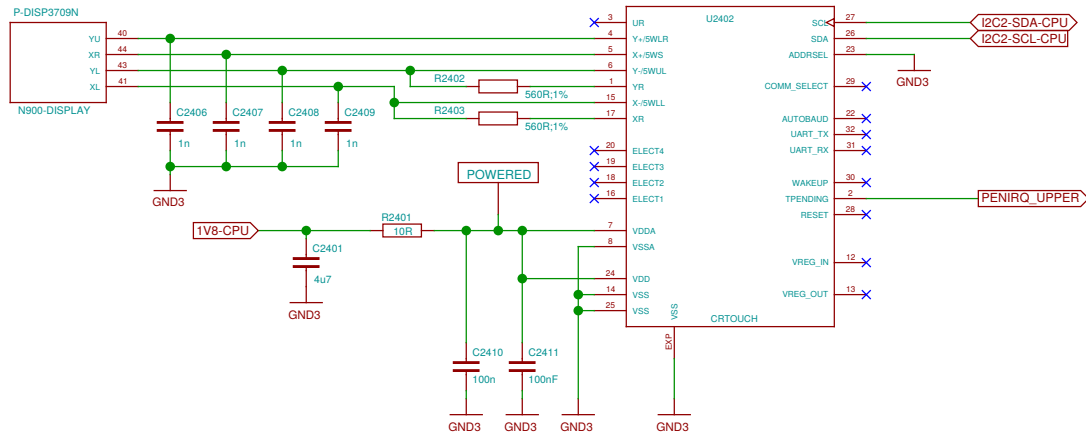

TODO: connector pin assignment needs intensive review

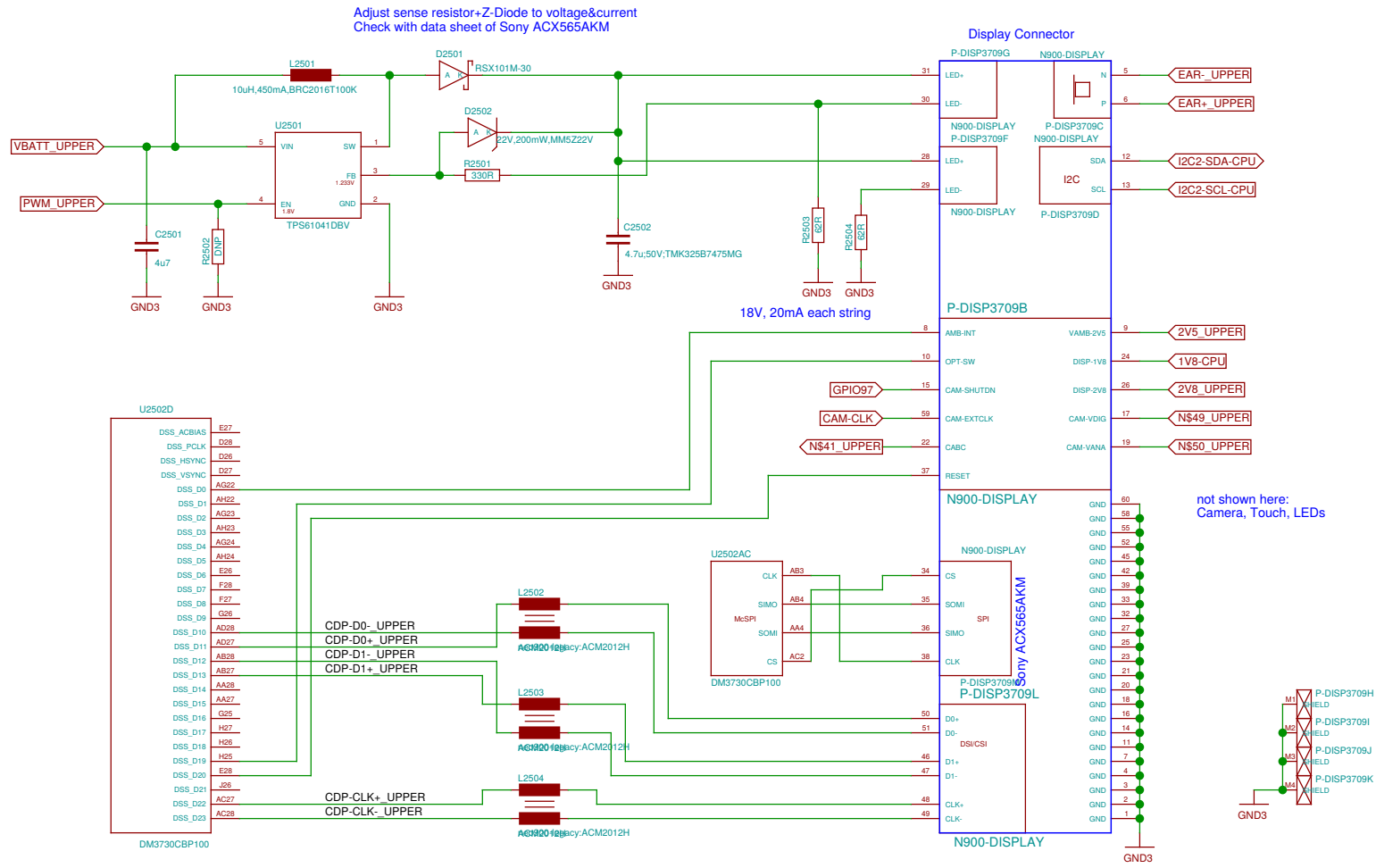

not shown here:
Camera, Touch, LEDs

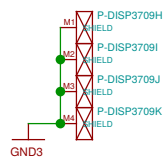

INCOMPLETE in V2

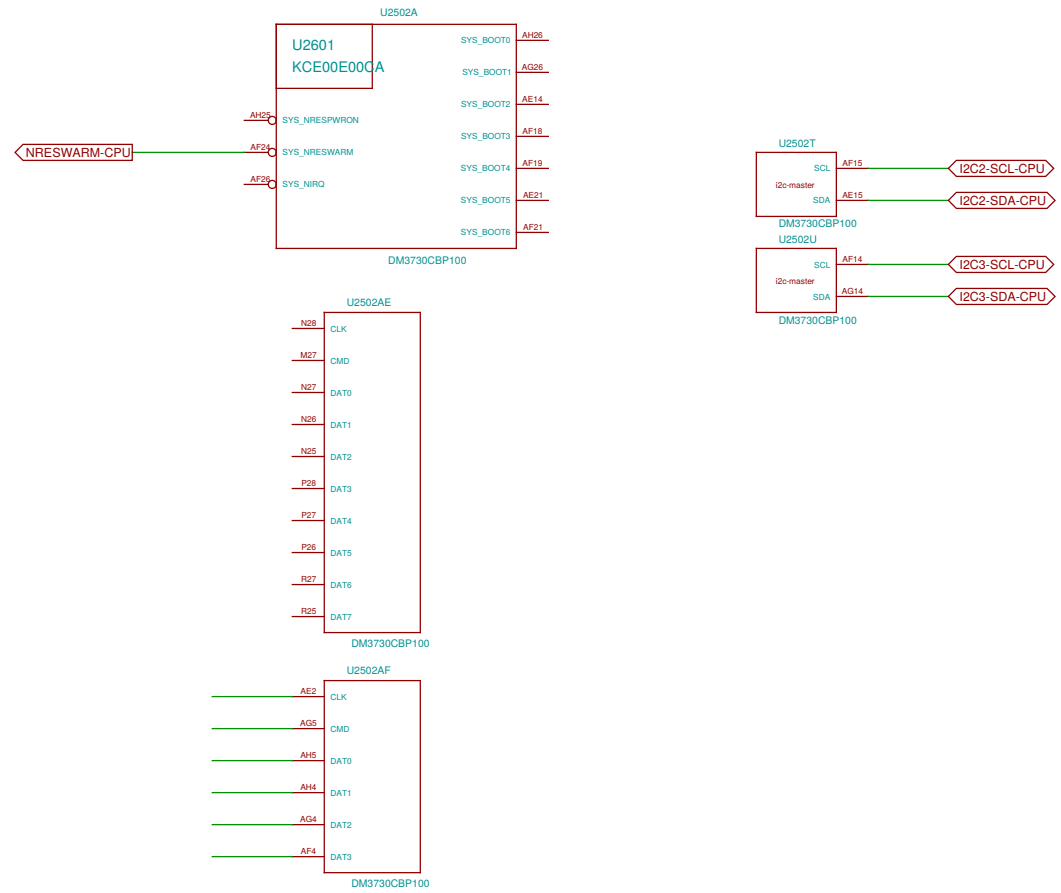

Sheet: /CPU + PoP RAM/NAND/ File: neo900_SS_26.sch		
Title: CPU + PoP RAM/NAND		
Size: A3	Date: 17 JUL 2016	Rev:
Plotted by eeshow b830f90+ 20160924-19:35Z		Id: 26/37

INCOMPLETE in V2

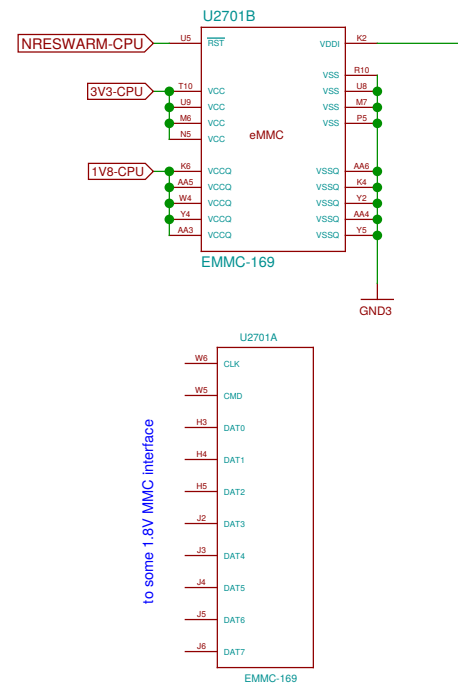

Sheet: /eMMC/ File: neo900_SS_27.sch	
Title: eMMC	
Size: A3	Date: 17 JUL 2016
Plotted by eeshow b830190- 20160924-19:35Z	Rev: Id: 27/37

TODO: check role

INCOMPLETE in V2

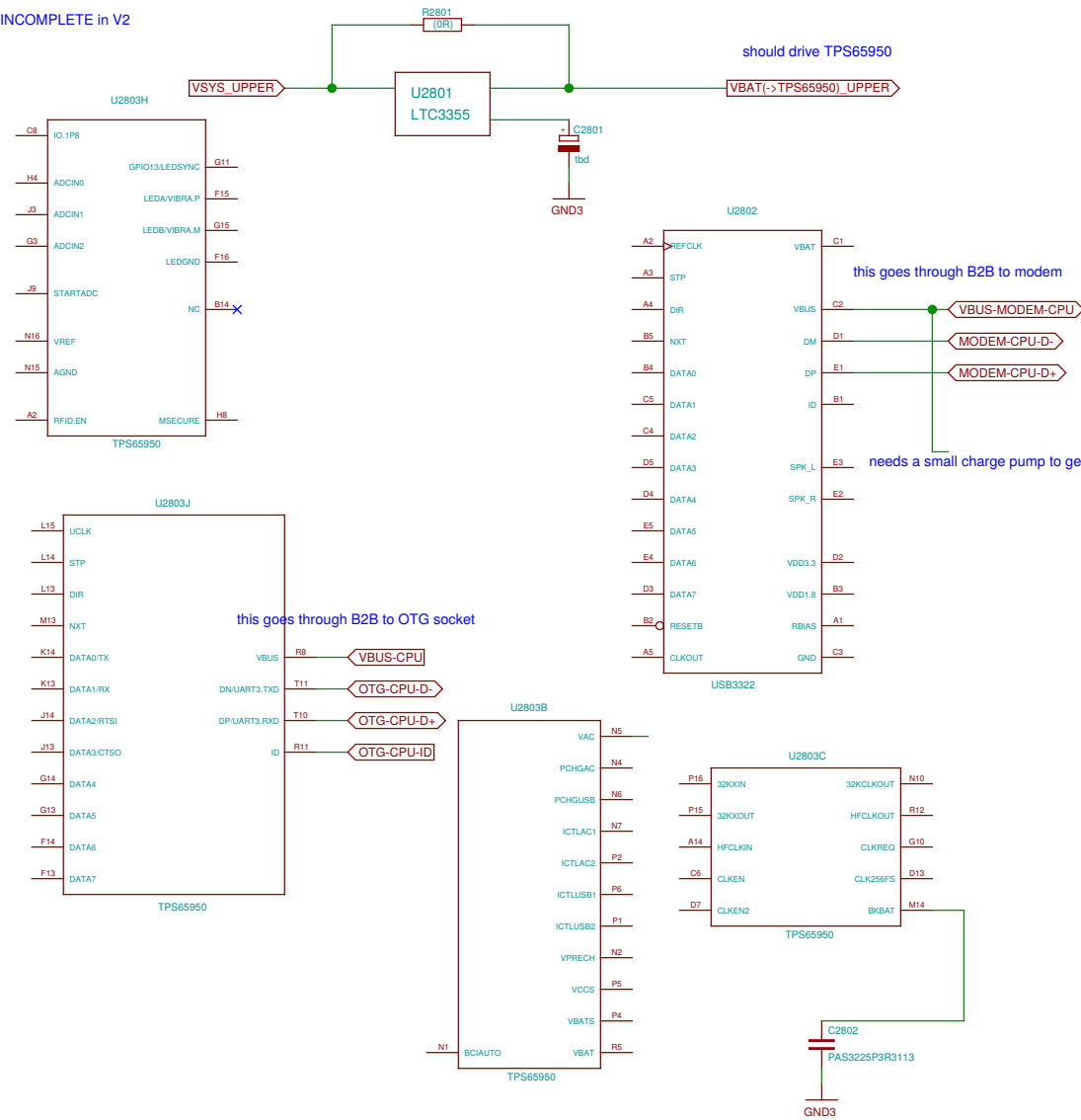

TODO: VBUS-MODEM ?

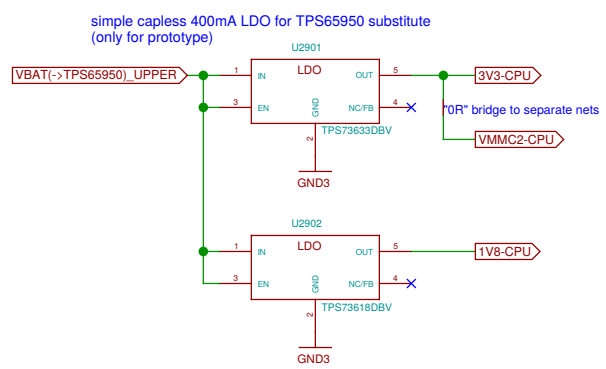

Sheet: /BB-XM Dummy (TWL4030)/			
File: neo900_SS_29.sch			
Title: BB-XM Dummy (TWL4030)			
Size: A3	Date: 17 JUL 2016	Rev:	
Plotted by eeshow b830190- 20160924-19:35Z			Id: 29/37

INCOMPLETE in v2

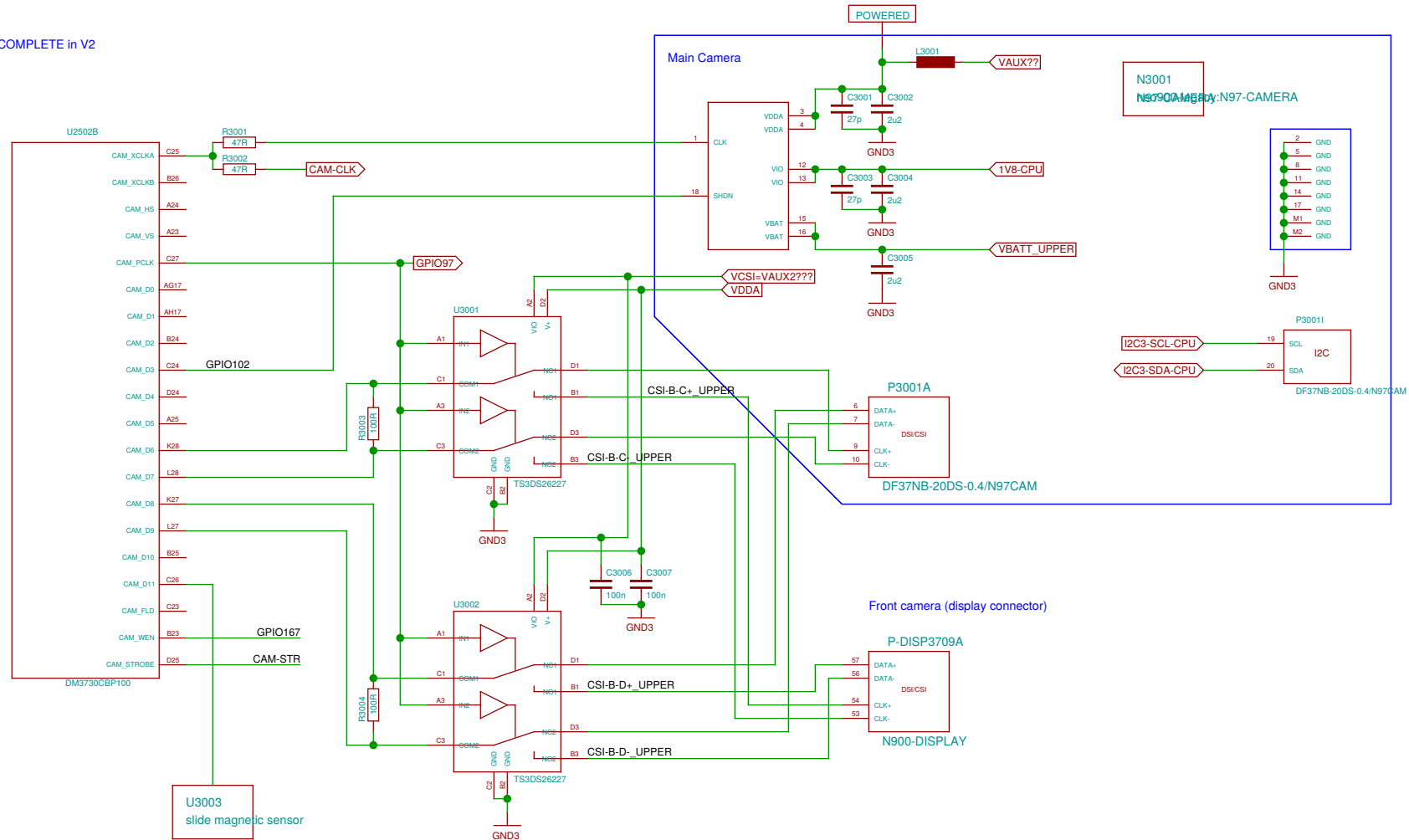

Sheet: /Camera/ File: neo900_SS_30.sch			
Title: Camera			
Size: A3	Date: 17 JUL 2016	Rev:	
Plotted by eeshow b830190 - 20160924-19:35Z		Id: 30/37	

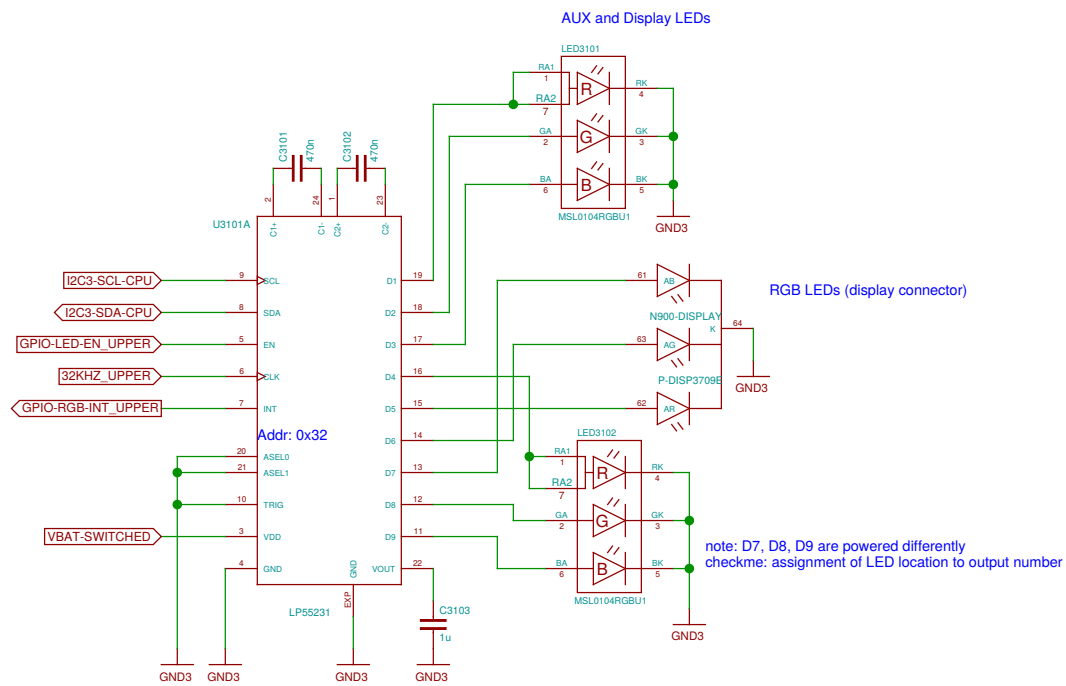

TODO: LEDs/Fancy LEDs sheets have title swapped

Sheet: /LEDs/ File: neo900_SS_31.sch		
Title: LEDs		
Size: A3	Date: 17 JUL 2016	Rev:
Plotted by eeshow b830190- 20160924-19:35Z		Id: 31/37

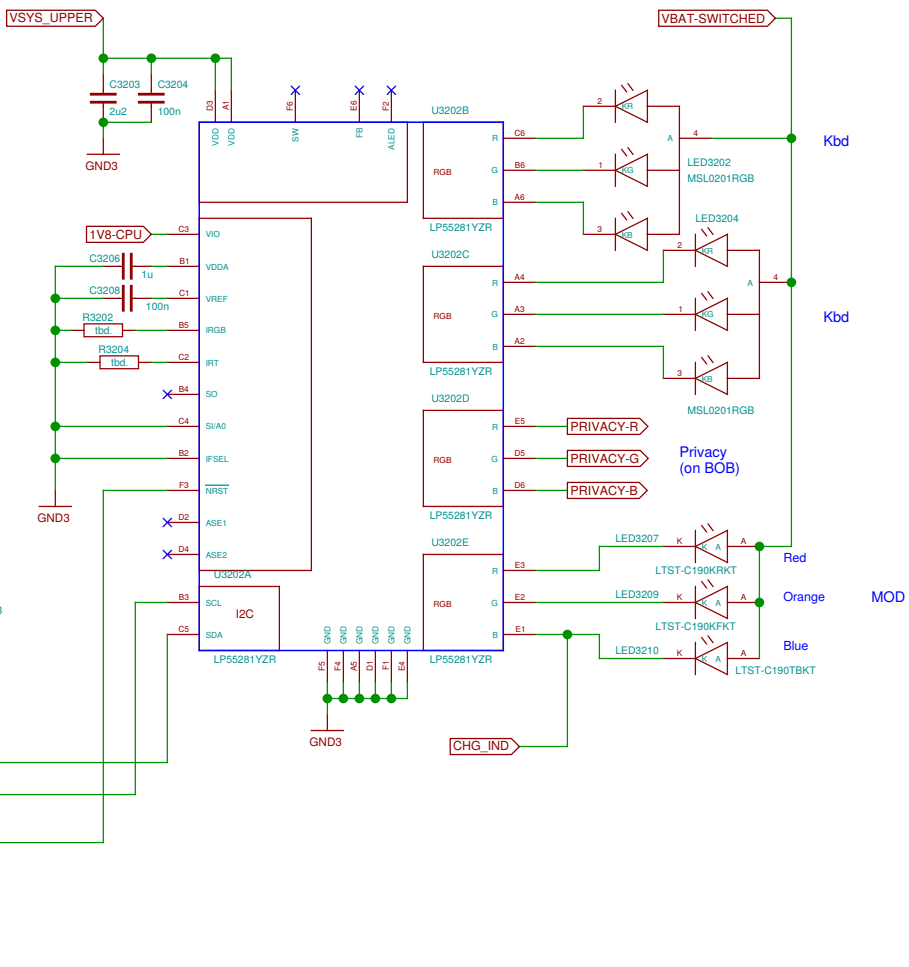
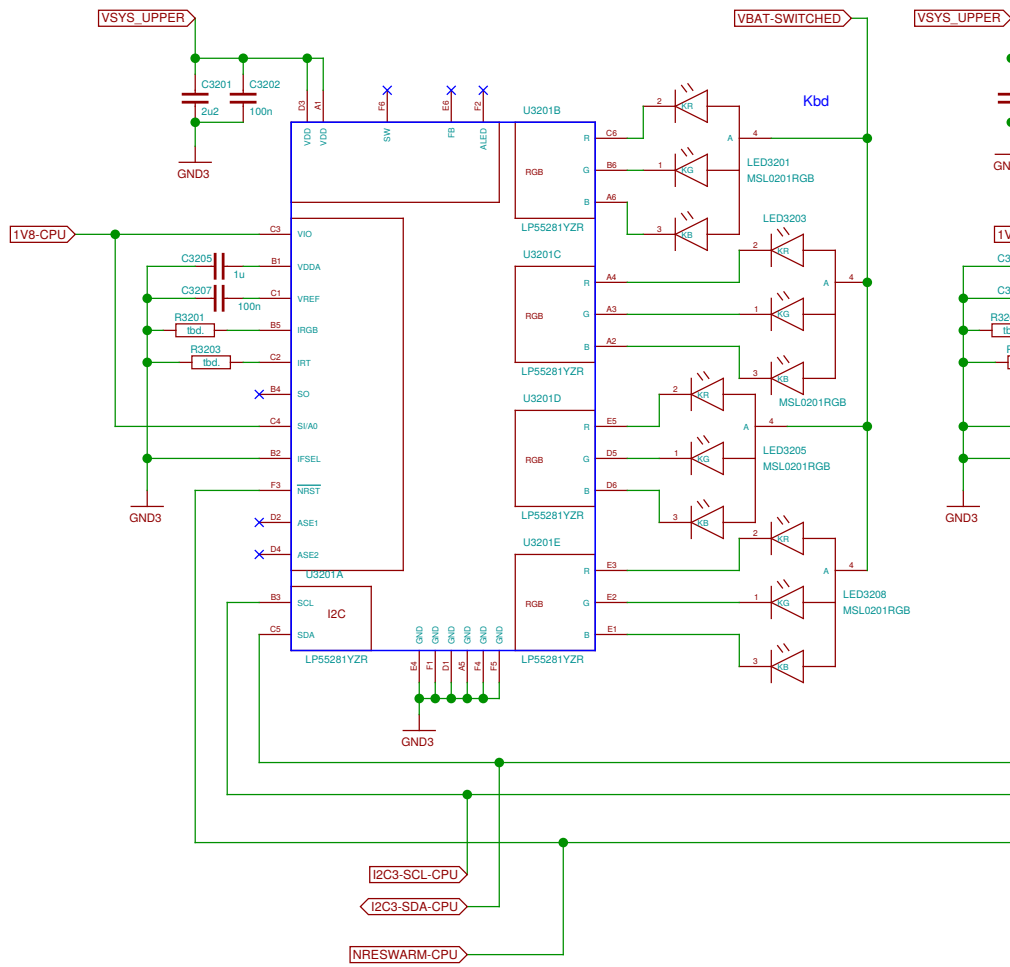

These connectors allow to "emulate" the DM3730 by connecting a BB-XM

INCOMPLETE
prototype only

Connect to OMAP3 McSPI1, I2C2, MMC2 / some GPIOs

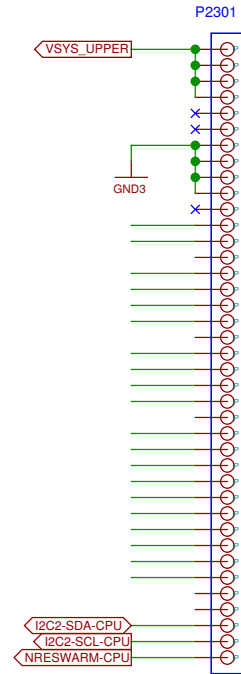

connect to respective CPU-pads

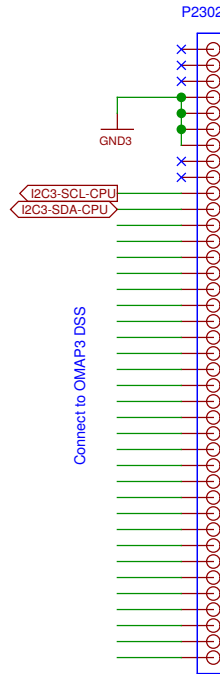

Connect to OMAP3 DSS

DSS / GPIOs, I2C3

Connect to OMAP3 Camera

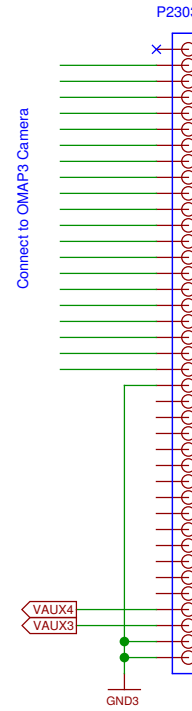

connect to BB
by some Micro-USB cable

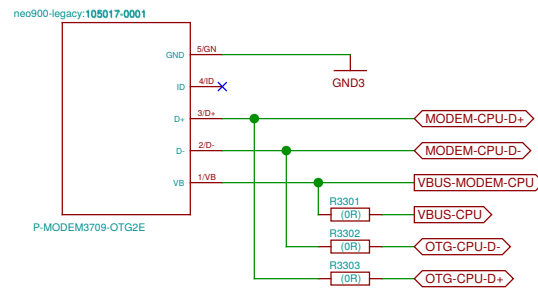

TODO: VBUS-MODEM ?

Sheet: /Connector to BB-XM/ File: neo900_SS_33.sch	
Title: Connector to BB-XM	
Size: A3	Date: 17 JUL 2016
Plotted by eeshow b830190+ 20160924-19:35Z	Rev: Id: 33/37

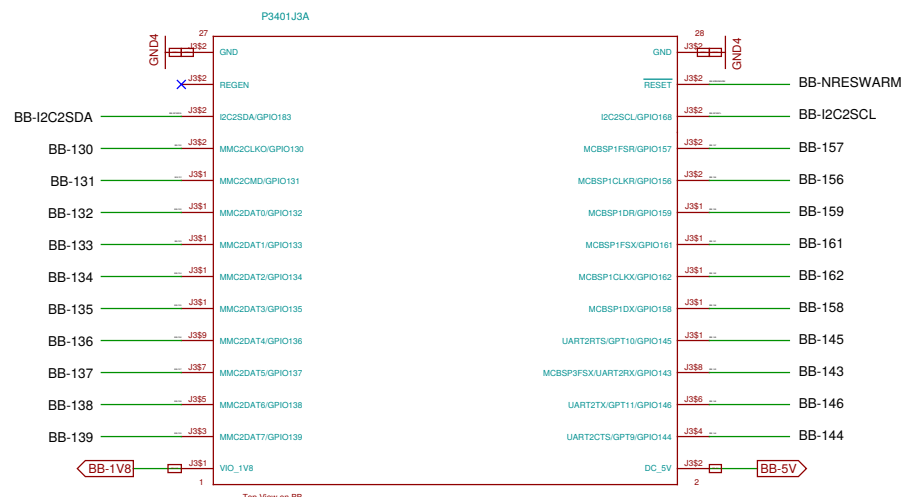
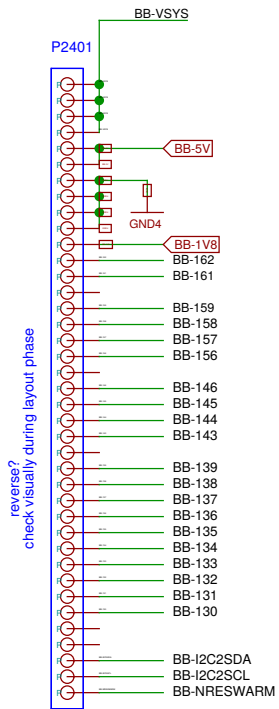
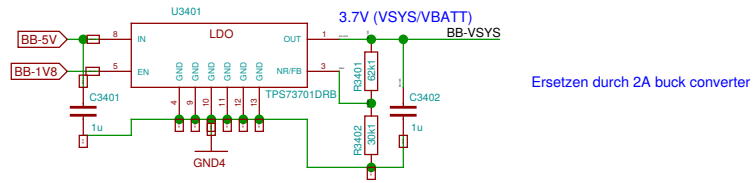

BB-xM Main Expansion Header (7.24)

TODO: needs decision on where to take this

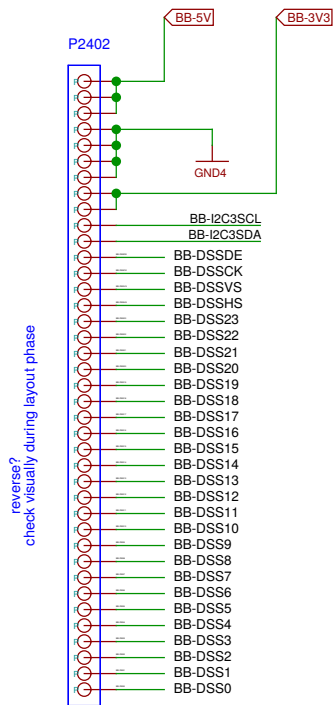

reverse?
check visually during layout phase

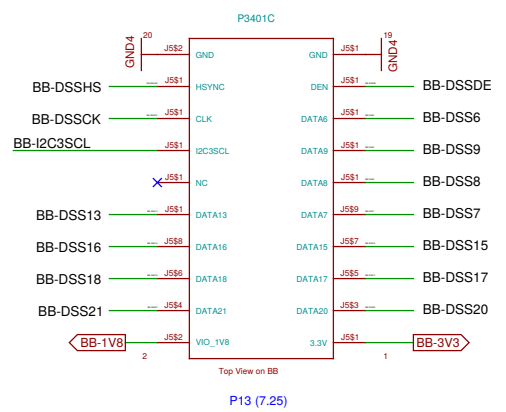
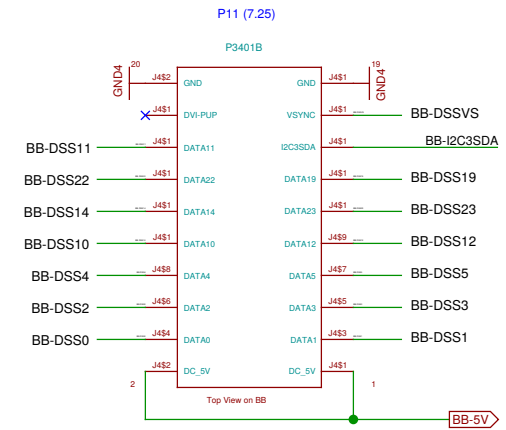

TODO: needs decision on where to take this

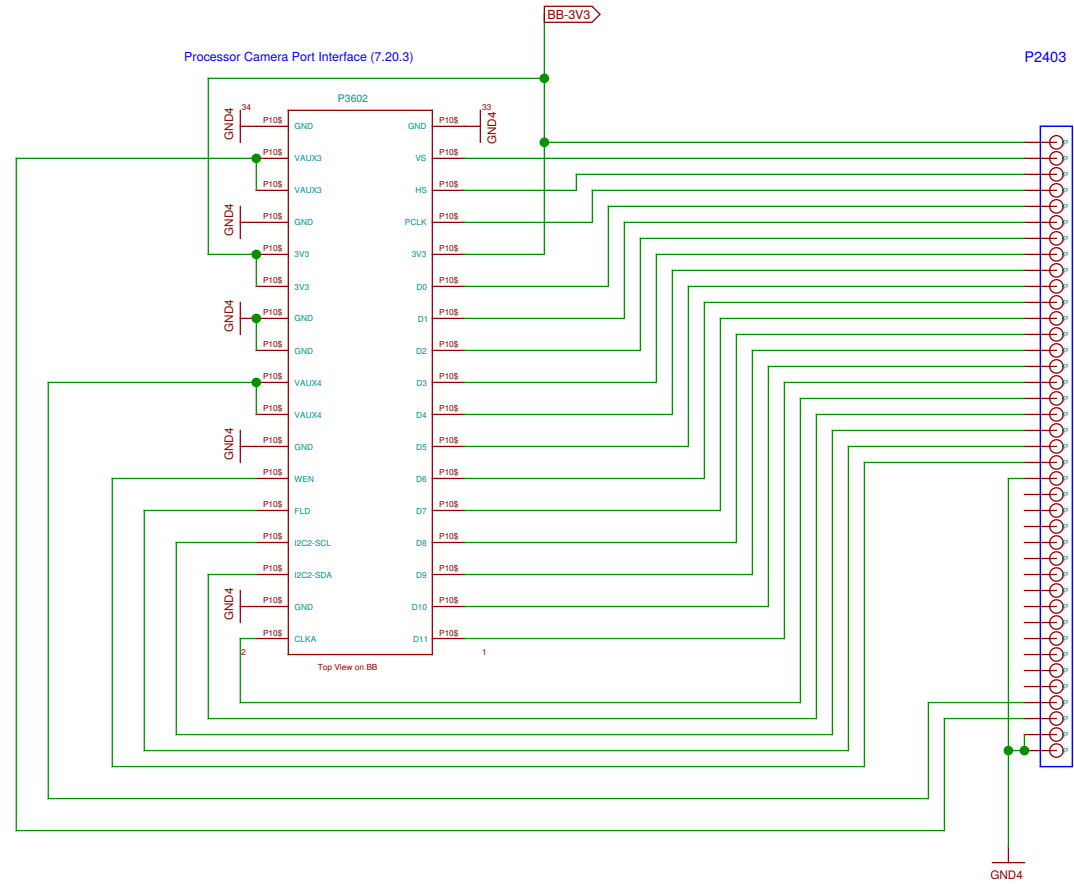

reverse?
check visually during layout phase

Sheet: /BB-XM Adapter (CAM)/		Date: 17 JUL 2016	
File: neo900_SS_36.sch		Rev:	
Title: BB-XM Adapter (CAM)			
Size: A3	Date: 17 JUL 2016		Rev:
Plotted by eeshow b830190 - 20160924-19:35Z			Id: 36/37

Molex Jumper cables to connect BB-XM-Adapter to Uppwer board

N3701 15015-0439	N3702 15015-0439	N3703 15015-0439
CPU	DISP	CAM

N3704 N900 case assembly

N3705 N97-CAMERA-HOLE

N3706 headset jack

N3707 STENCIL-TOP

N3708 STENCIL-BOTTOM

Sheet: /No-Solder Components/ File: neo900_SS_37.sch		
Title: No-Solder Components		
Size: A3	Date: 17 JUL 2016	Rev:
Plotted by eeshow b830190+ 20160924-19:35Z		Id: 37/37