

Click | Here

This sheet: [index](#)

[Sheet: OTG](#)  
File: neo900\_SS\_2.sch  
**OTG & Switches**

[Sheet: Charger/OTG-Booster](#)  
File: neo900\_SS\_3.sch  
**Charger/OTG-Booster**

[Sheet: Modem Power](#)  
File: neo900\_SS\_4.sch  
**Modem Power**

[Sheet: Fuel Gauge](#)  
File: neo900\_SS\_5.sch  
**Fuel Gauge**

[Sheet: 3G/4G Modem + SIM](#)  
File: neo900\_SS\_6.sch  
**3G/4G Modem + SIM**

[Sheet: Dual SIM switch](#)  
File: neo900\_SS\_7.sch  
**Dual SIM switch**

[Sheet: Antenna connections](#)  
File: neo900\_SS\_8.sch  
**Antenna connections**

[Sheet: WLAN, Bluetooth, FM](#)  
File: neo900\_SS\_9.sch  
**WLAN, Bluetooth, FM**

[Sheet: Sensors](#)  
File: neo900\_SS\_10.sch  
**Sensors**

[Sheet: Audio Codec](#)  
File: neo900\_SS\_11.sch  
**Audio Codec**

[Sheet: Audio Headset + Mic](#)  
File: neo900\_SS\_12.sch  
**Audio Headset + Mic**

[Sheet: ECI](#)  
File: neo900\_SS\_13.sch  
**ECI**

[Sheet: Audio Handsfree](#)  
File: neo900\_SS\_14.sch  
**Audio Handsfree**

[Sheet: Misc \(lower\)](#)  
File: neo900\_SS\_15.sch  
**Misc (lower)**

[Sheet: RFID/NFC Reader](#)  
File: neo900\_SS\_16.sch  
**RFID/NFC Reader**

[Sheet: RFID/NFC Controller](#)  
File: neo900\_SS\_17.sch  
**RFID/NFC Controller**

[Sheet: Hackerbus](#)  
File: neo900\_SS\_18.sch  
**Hackerbus**

[Sheet: Infrared](#)  
File: neo900\_SS\_19.sch  
**Infrared**

[Sheet: B2B to UPPER](#)  
File: neo900\_SS\_20.sch  
**B2B to UPPER**

[Sheet: uSD Breakout Board](#)  
File: neo900\_SS\_21.sch  
**uSD Breakout Board**

[Sheet: B2B to LOWER](#)  
File: neo900\_SS\_22.sch  
**B2B to LOWER**

[Sheet: Keypad](#)  
File: neo900\_SS\_23.sch  
**Keypad**

[Sheet: Display-Peripherals](#)  
File: neo900\_SS\_24.sch  
**Display-Peripherals**

[Sheet: Display-Panel&Power](#)  
File: neo900\_SS\_25.sch  
**Display-Panel&Power**

Click | Here

[Sheet: CPU + PoP RAM/NAND](#)  
File: neo900\_SS\_26.sch  
**CPU + PoP RAM/NAND**

[Sheet: eMMC](#)  
File: neo900\_SS\_27.sch  
**eMMC**

[Sheet: PMU+Codec](#)  
File: neo900\_SS\_28.sch  
**PMU+Codec**

[Sheet: BB-XM Dummy \(TWL4030\)](#)  
File: neo900\_SS\_29.sch  
**BB-XM Dummy (TWL4030)**

[Sheet: Camera](#)  
File: neo900\_SS\_30.sch  
**Camera**

[Sheet: LEDs](#)  
File: neo900\_SS\_31.sch  
**LEDs**

[Sheet: Fancy LEDs](#)  
File: neo900\_SS\_32.sch  
**Fancy LEDs**

[Sheet: Connector to BB-XM](#)  
File: neo900\_SS\_33.sch  
**Connector to BB-XM**

[Sheet: BB-XM Adapter \(CPU\)](#)  
File: neo900\_SS\_34.sch  
**BB-XM Adapter (CPU)**

[Sheet: BB-XM Adapter \(DISP\)](#)  
File: neo900\_SS\_35.sch  
**BB-XM Adapter (DISP)**

[Sheet: BB-XM Adapter \(CAM\)](#)  
File: neo900\_SS\_36.sch  
**BB-XM Adapter (CAM)**

[Sheet: No-Solder Components](#)  
File: neo900\_SS\_37.sch  
**No-Solder Components**

Note regarding I2C addresses:  
Addresses in the schematics are provided for convenience.  
The authoritative source is  
<https://neo900.org/git?p=misc;a=tree;f=i2c>

Sheet: /		
File: neo900.sch		
Title: Neo900		
Size: A3	Date: 16 JUL 2016	Rev:
Plotted by eeshow 14908eb+ 20160930-18:22Z		Id: 1/37

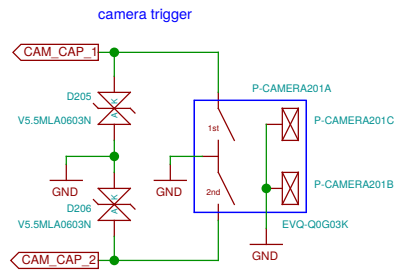
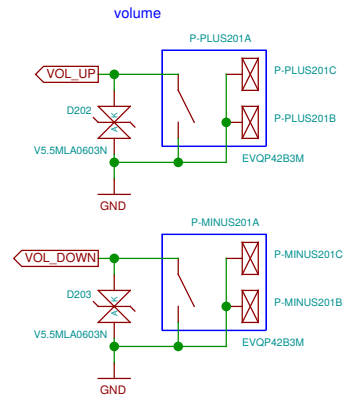
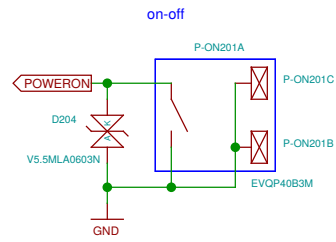
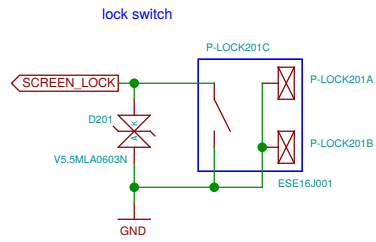

can be used to test/operate the modem through the OTG port (w/o UPPER PCB)

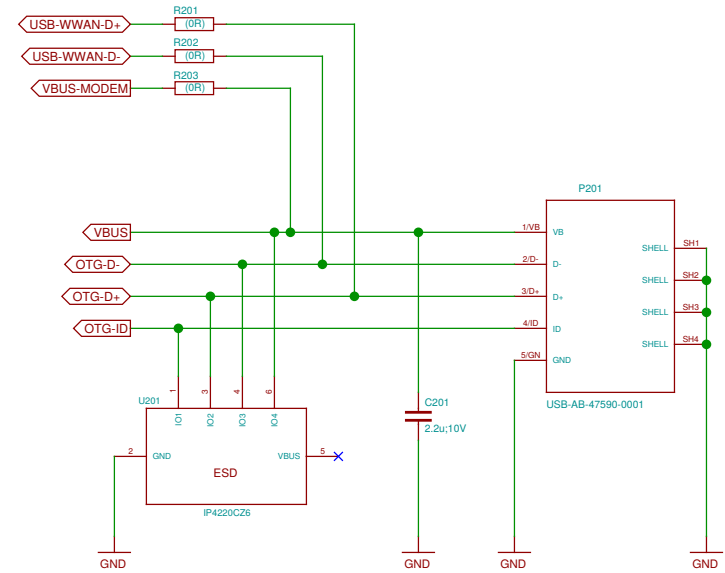

place in scan matrix? would need 3-4 wires to UPPER board instead of 2

in any case it is sufficient to connect GPIO-VOL+ and VOL- to two pins on the B2B connector

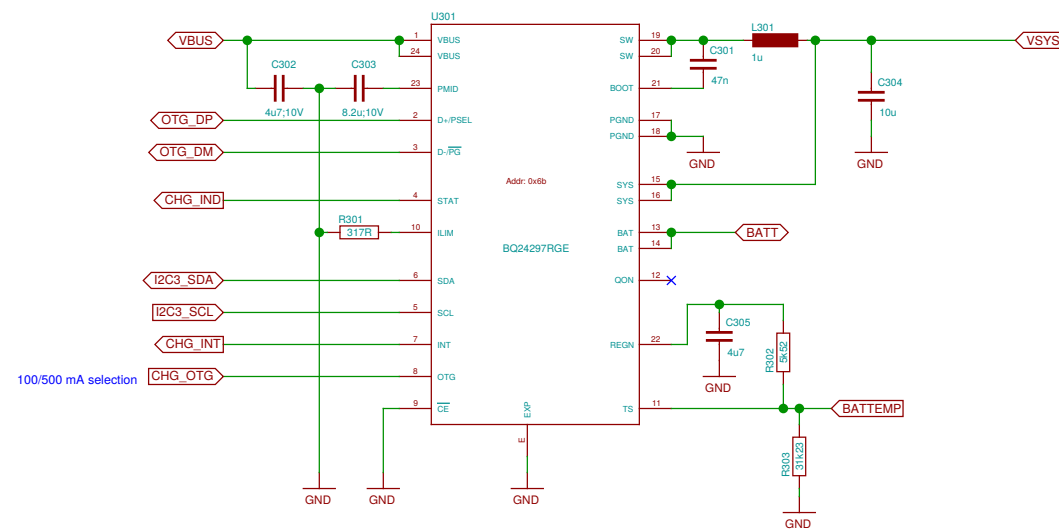

Sheet: /Charger/OTG-Booster/		
File: neo900_SS_3.sch		
Title: Charger/OTG-Booster		
Size: A3	Date: 17 JUL 2016	Rev:
Plotted by eeshow 14908eb+ 20160930-18:22Z		Id: 3/37

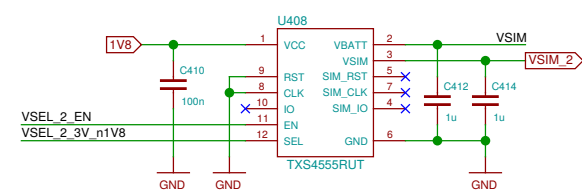
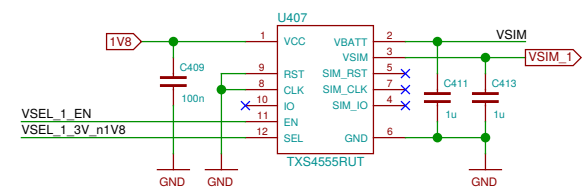
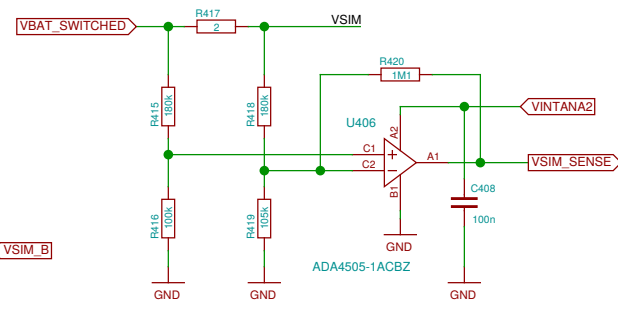
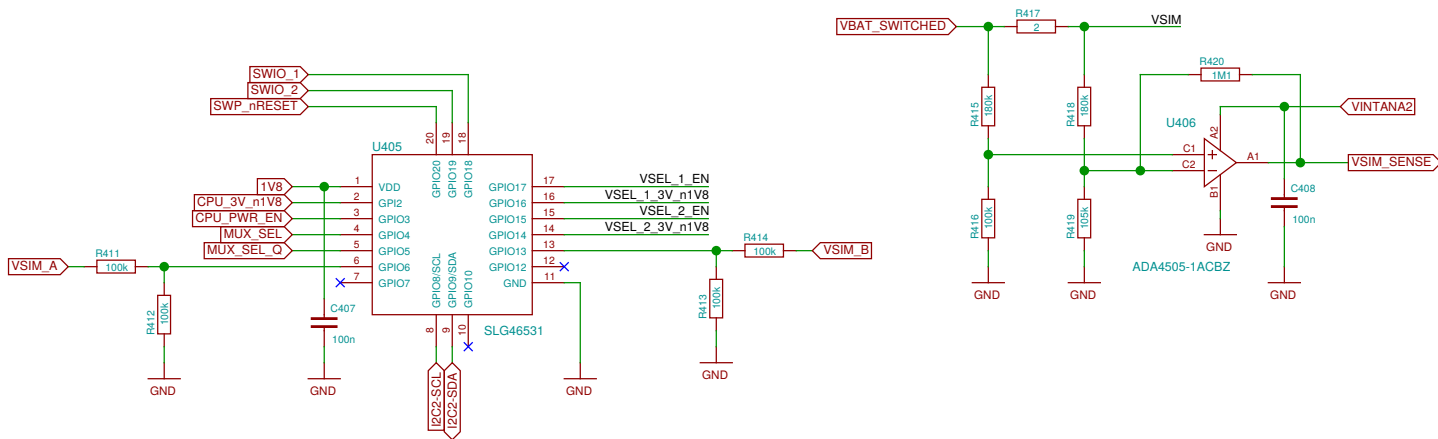
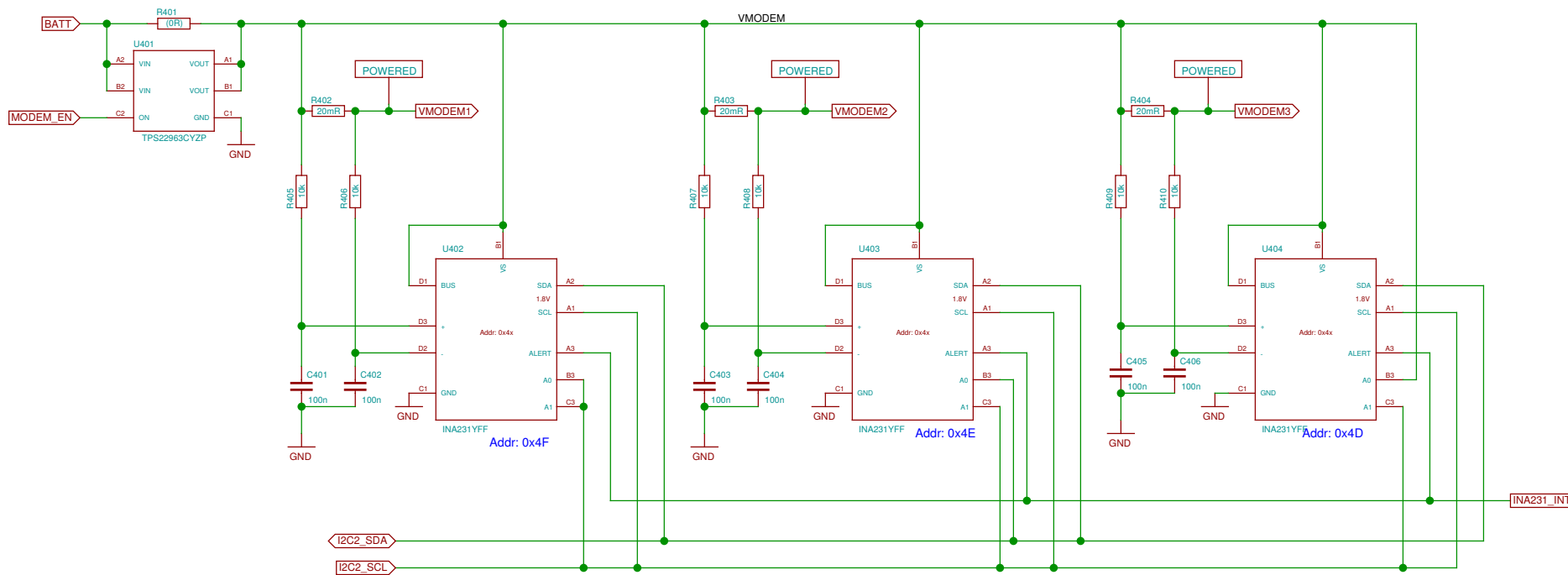

**TODO: update SLG design for changed pins**

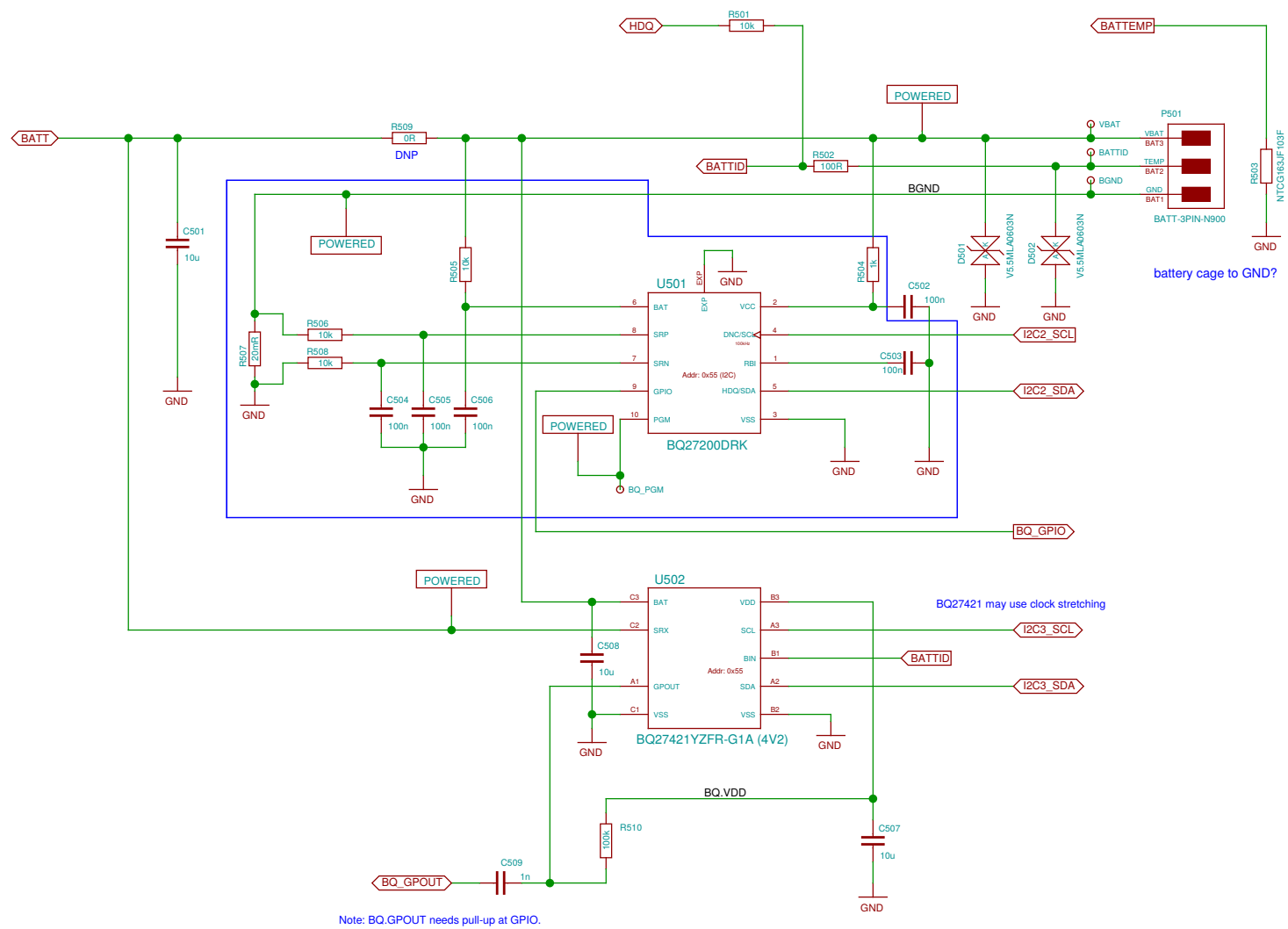

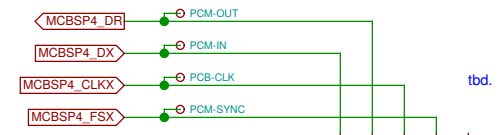
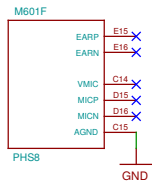

tbd.

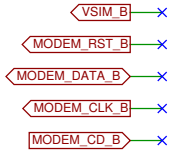

# TODO: B-SIM bus FFS

Can we connect UART in parallel to Bluetooth UART (i.e. if BT is disabled we can unbrick the Modem?)

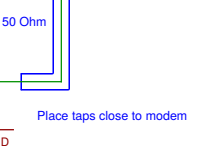
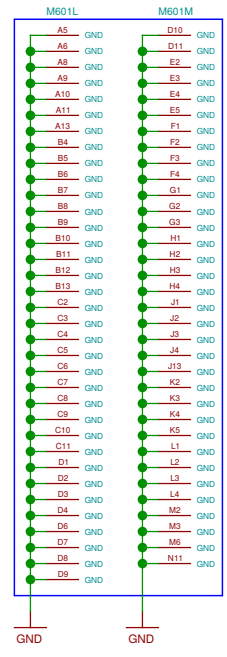
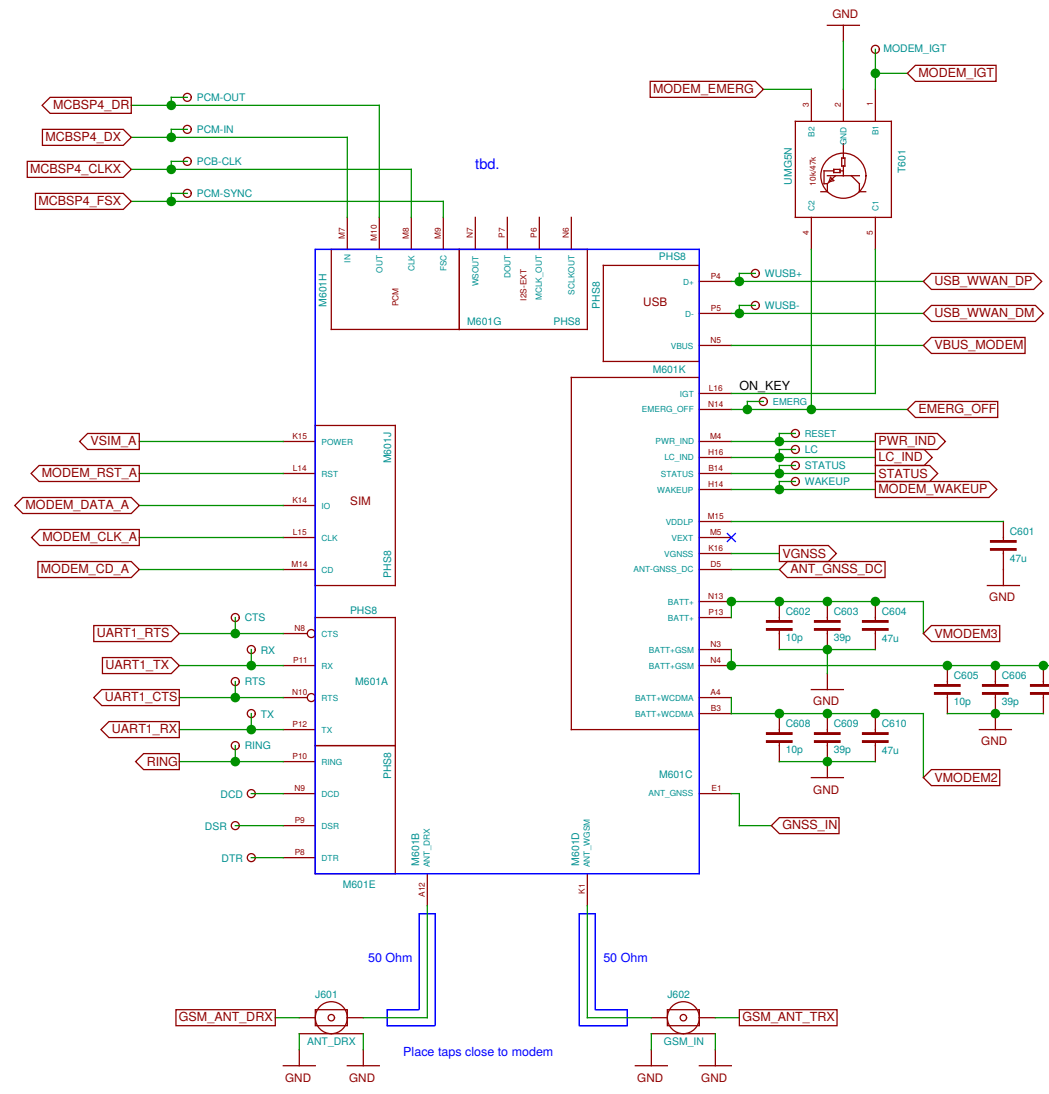

Note: MODEM\_CD\_\* (CCIN) is 1.8 V compatible.

Small logic gates are placed in close vicinity and share the bypass capacitor.

The FSA2866s operate at 3.3 V, for compatibility with Class B (2.7-3.3 V). The control inputs nOE and SEL are still 1.8 V compatible.

The delay timing is approximative. NXP provide the following formula:  $t_w = K * R * C = \text{approx. } 500 \text{ ms}$  for K estimated to be 0.5.

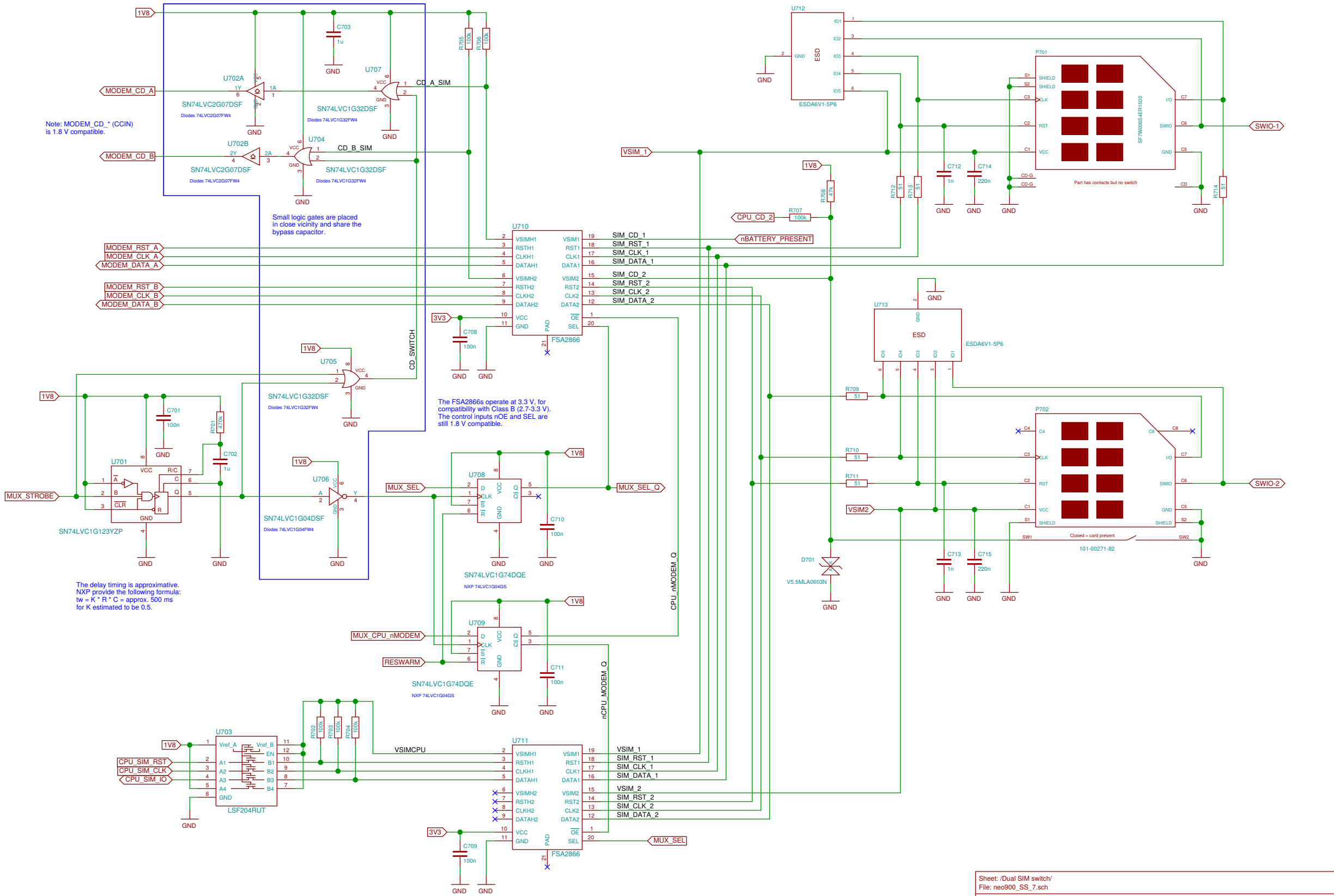

Sheet: /Dual SIM switch/		
File: neo900_SS_7.sch		
Title: Dual SIM switch		
Size: A3	Date: 17 JUL 2016	Rev:
Plotted by eshow 14908eb+ 20160930-18:22Z		Id: 7/37

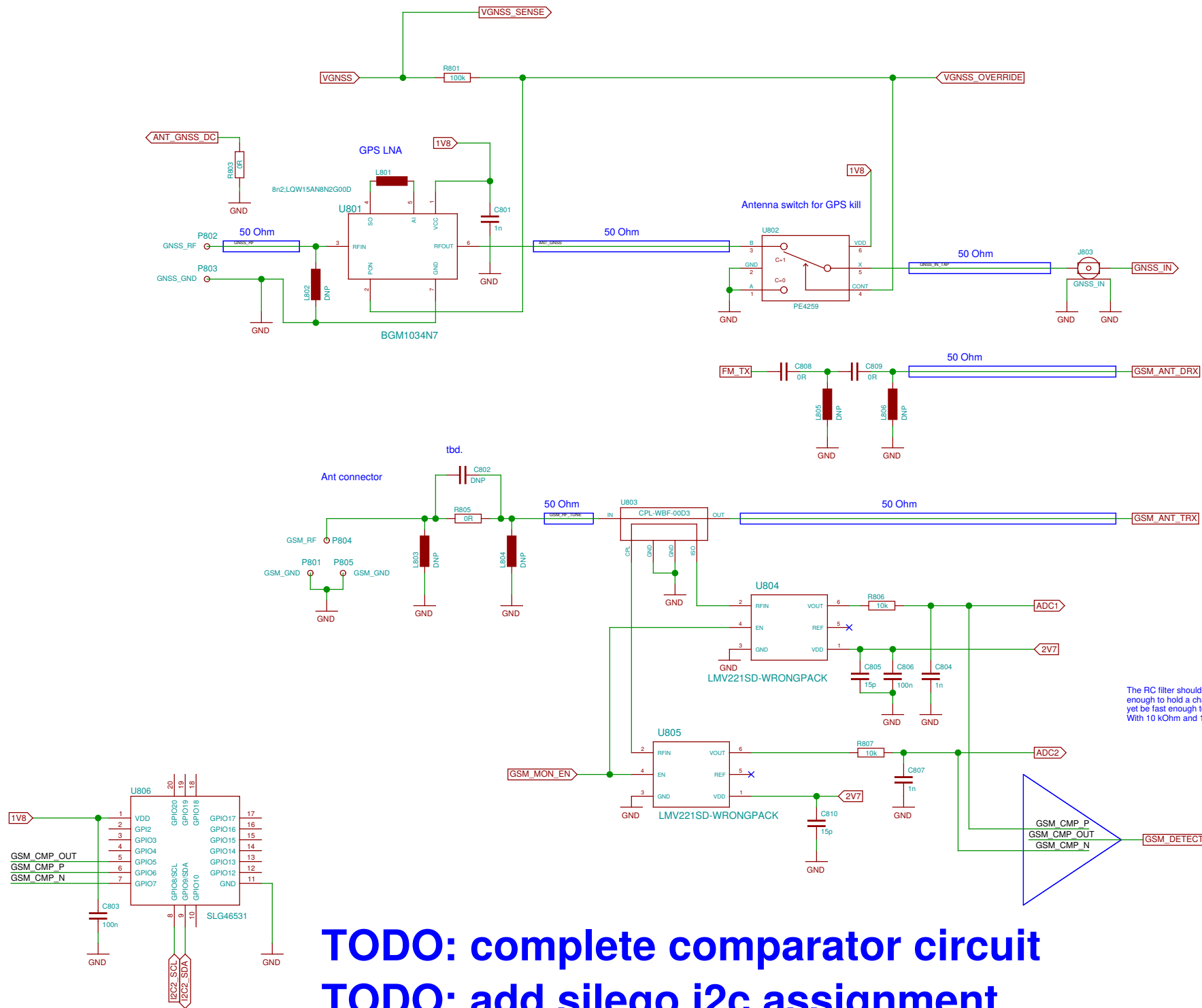

**TODO: complete comparator circuit**  
**TODO: add silego i2c assignment**  
**TODO: iox**



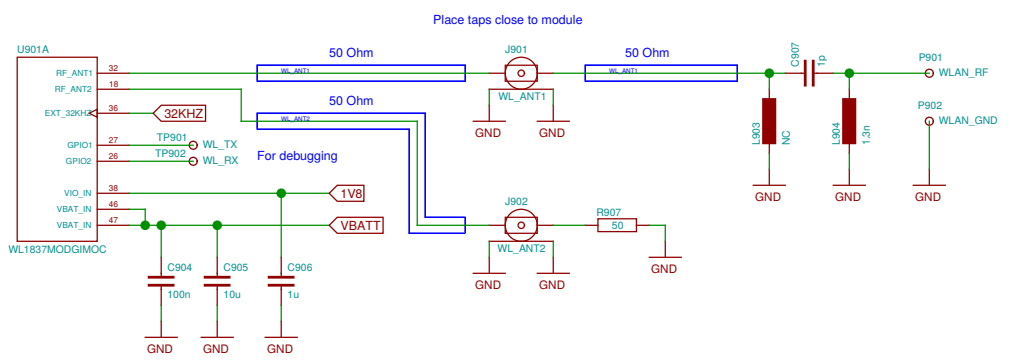

TODO: assign footprints

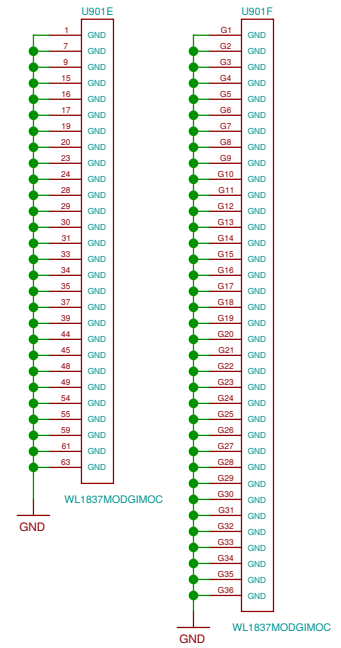
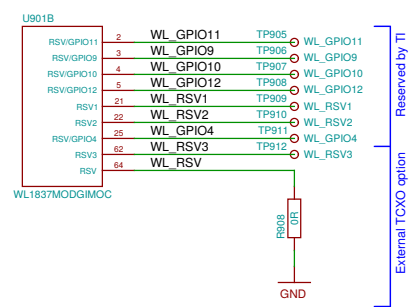
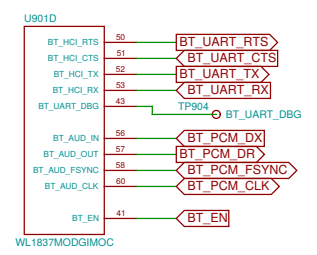
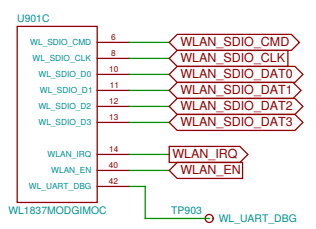

connect > 10cm loop or stub antenna

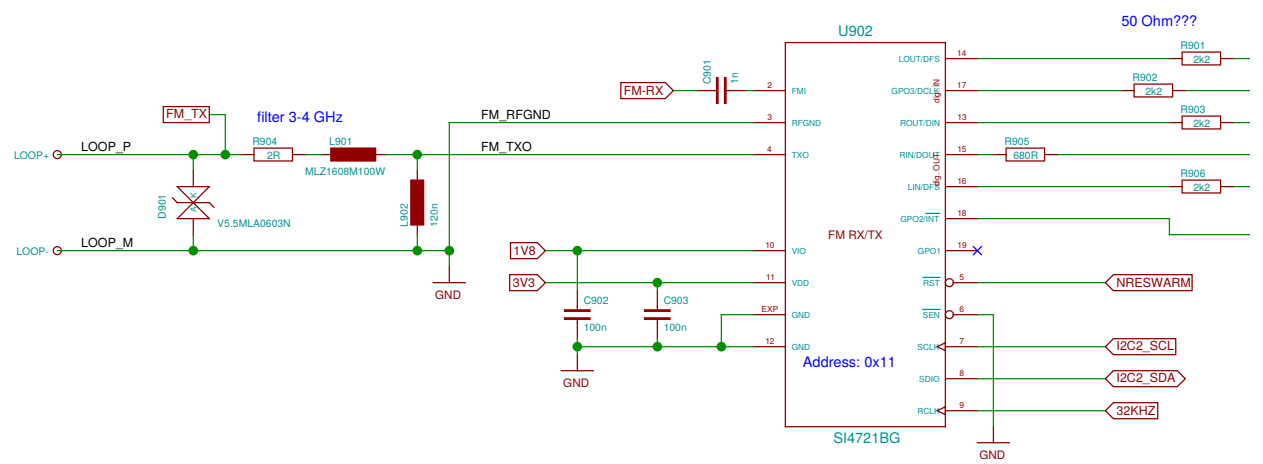

TODO: unfinished

- FSX
- CLKX
- DX
- DR
- FSR
- CLKR

Si4705 is pin compatible (mostly) but RX-only

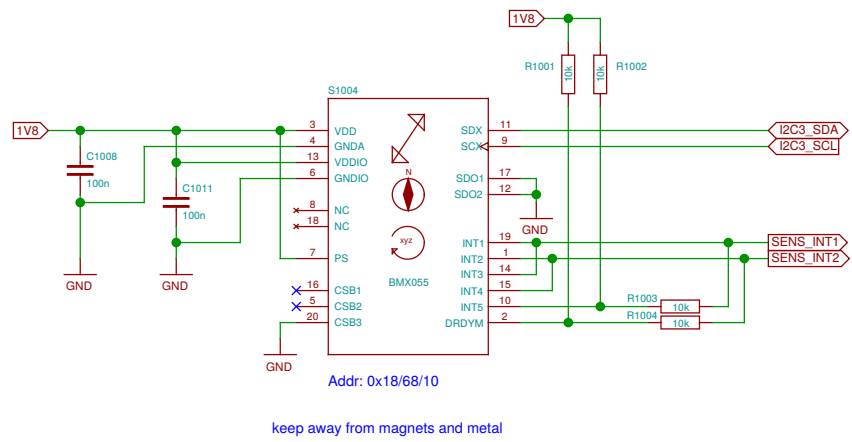
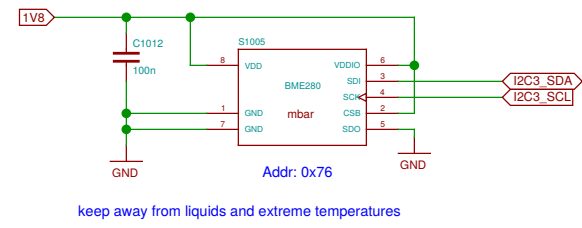
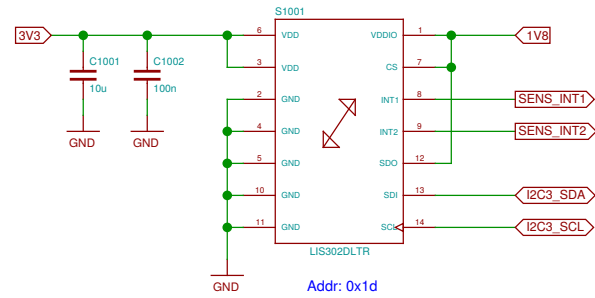

Sheet: /Sensors/ File: neo900_SS_10.sch	
Title: Sensors	
Size: A3	Date: 17 JUL 2016
Plotted by: eeshow 14908eb+ 20160930-18:22Z	Rev: Id: 10/37

problem: this is a 0.5mm BGA making lower board expensive  
 but it appears to be not extremely critical (only 3 rows and inner ring is GND)  
 problem: analog mic is on upper board  
 alternative: place on upper board (to be evaluated)

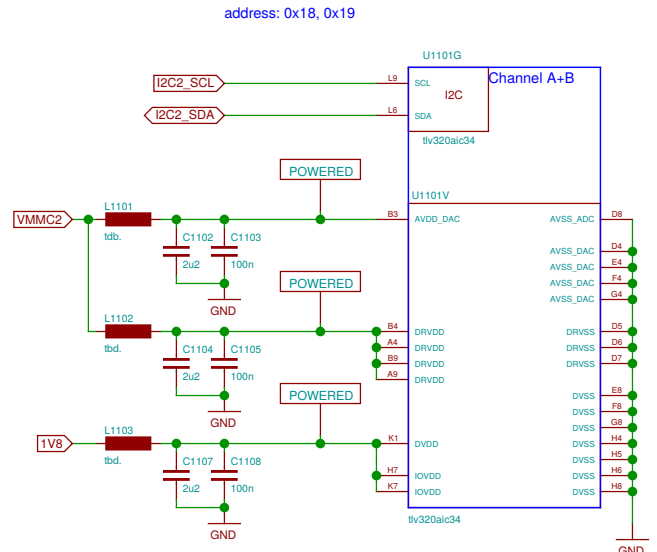
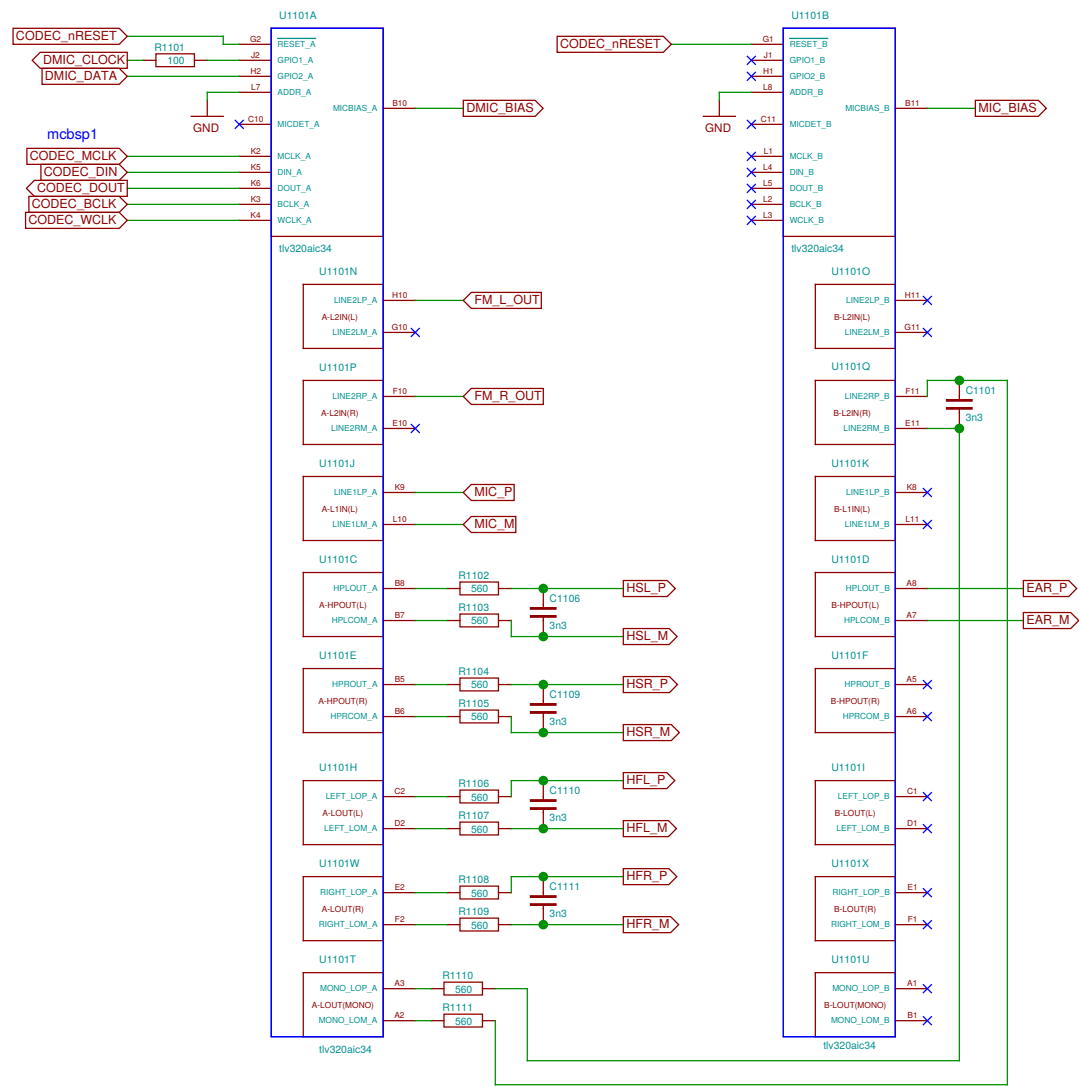

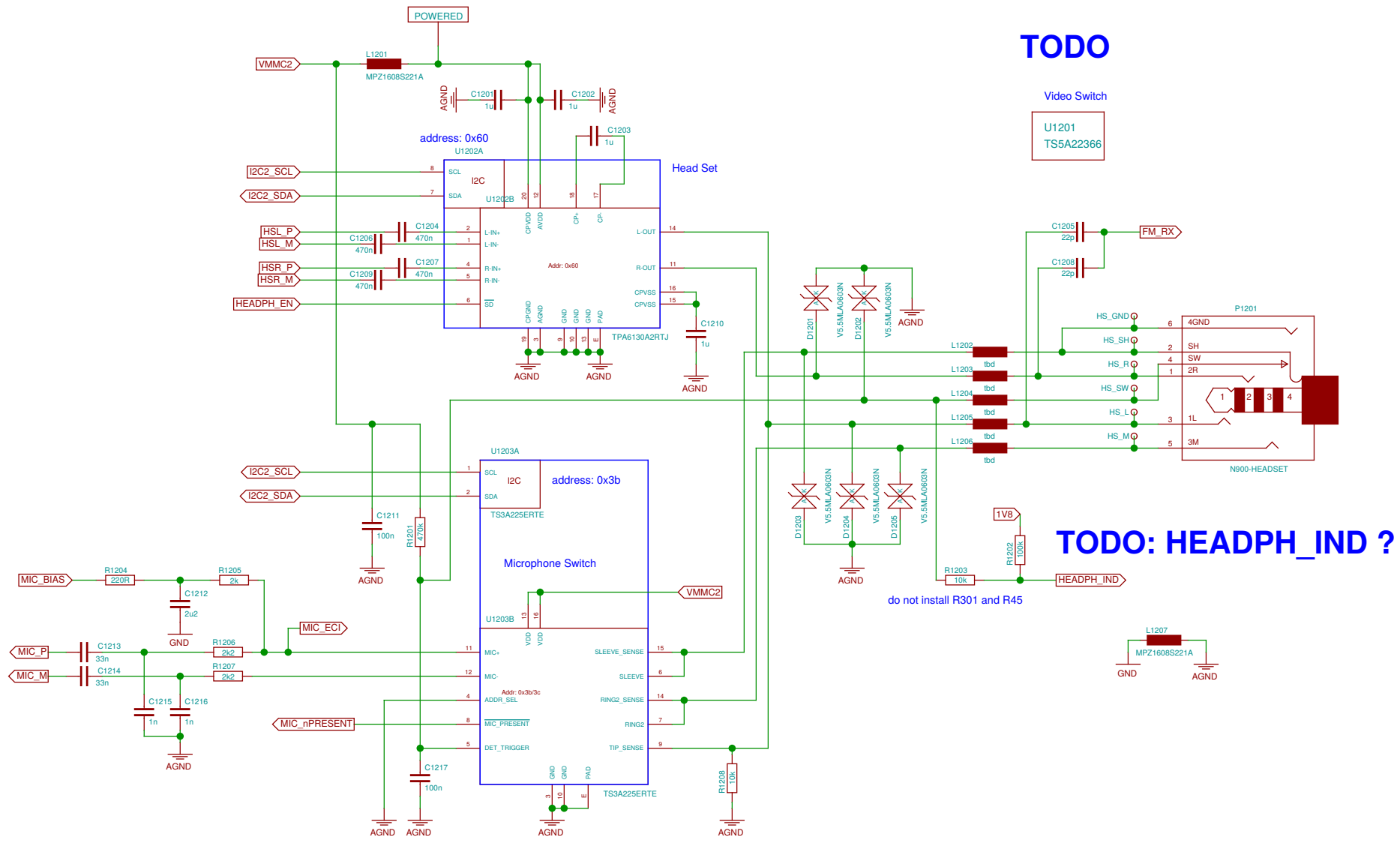

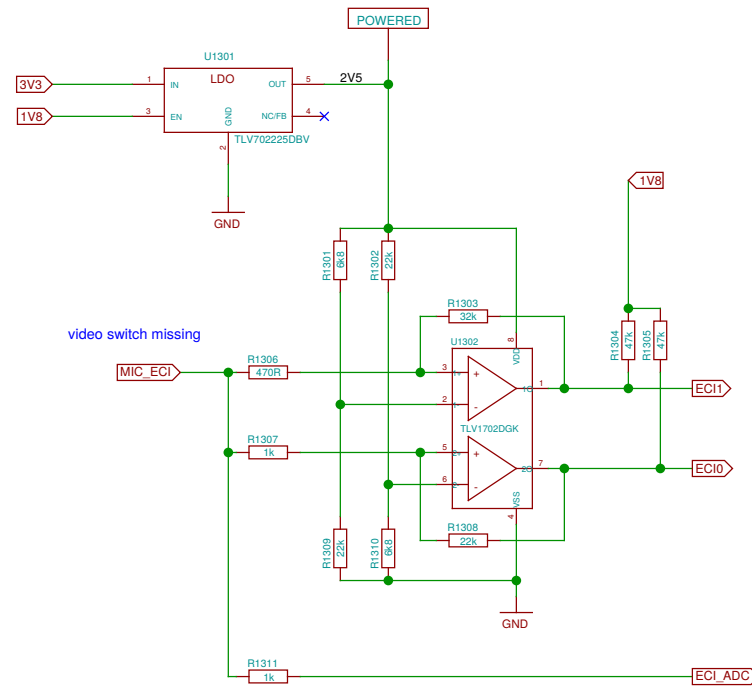

video switch missing

**TODO: draw comparator right**

Sheet: /ECI/		File: neo900_SS_13.sch	
Title: ECI			
Size: A3	Date: 17 JUL 2016	Rev:	
Plotted by eeshow 14908eb+ 20160930-18:22Z		Id: 13/37	

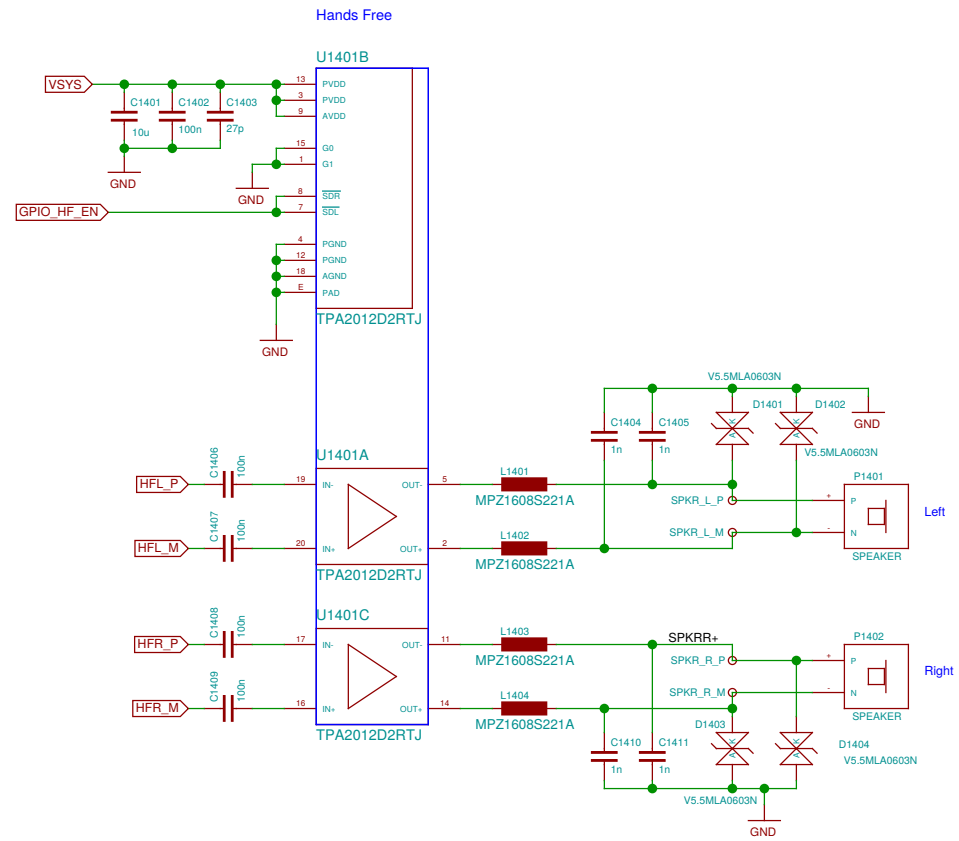

Sheet: /Audio Handsfree/		Date: 17 JUL 2016	
File: neo900_SS_14.sch		Rev:	
Title: Audio Handsfree			
Size: A3	Date: 17 JUL 2016	Rev:	
Plotted by eeshow 14908eb+ 20160930-18:22Z		Id: 14/37	

The LOWER-BOB interconnect is defined in the Hackerbus specification  
<http://neo900.org/stuff/papers/hb.pdf>

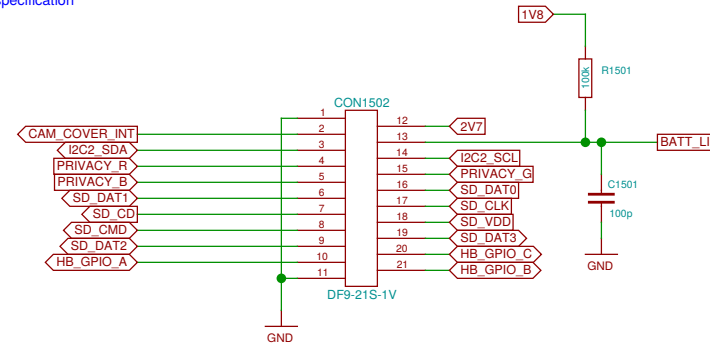
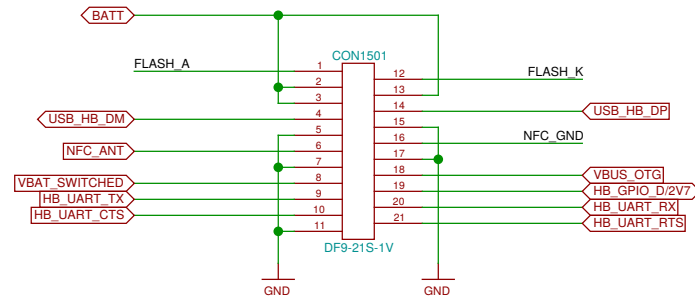

**TODO: define NFC-GND**

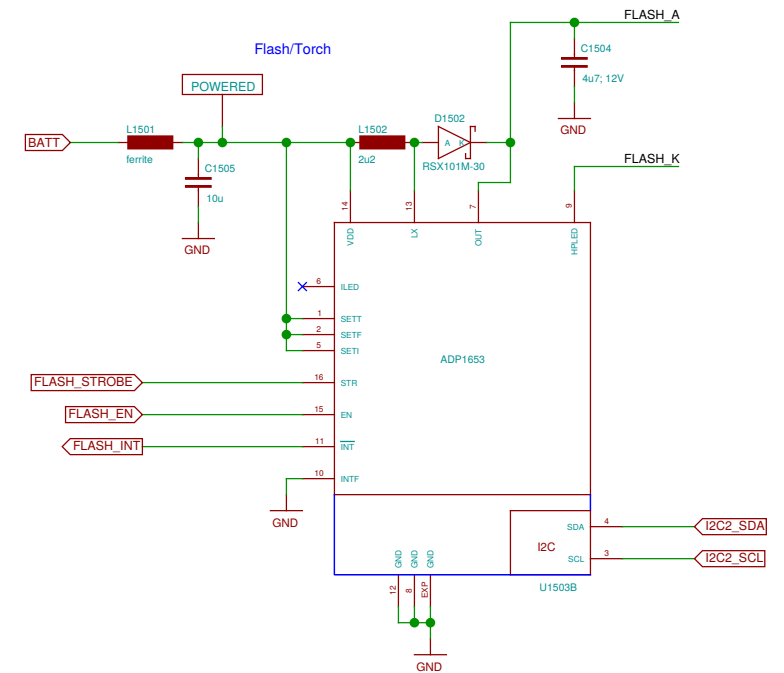
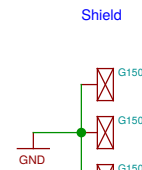
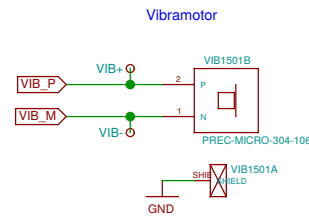

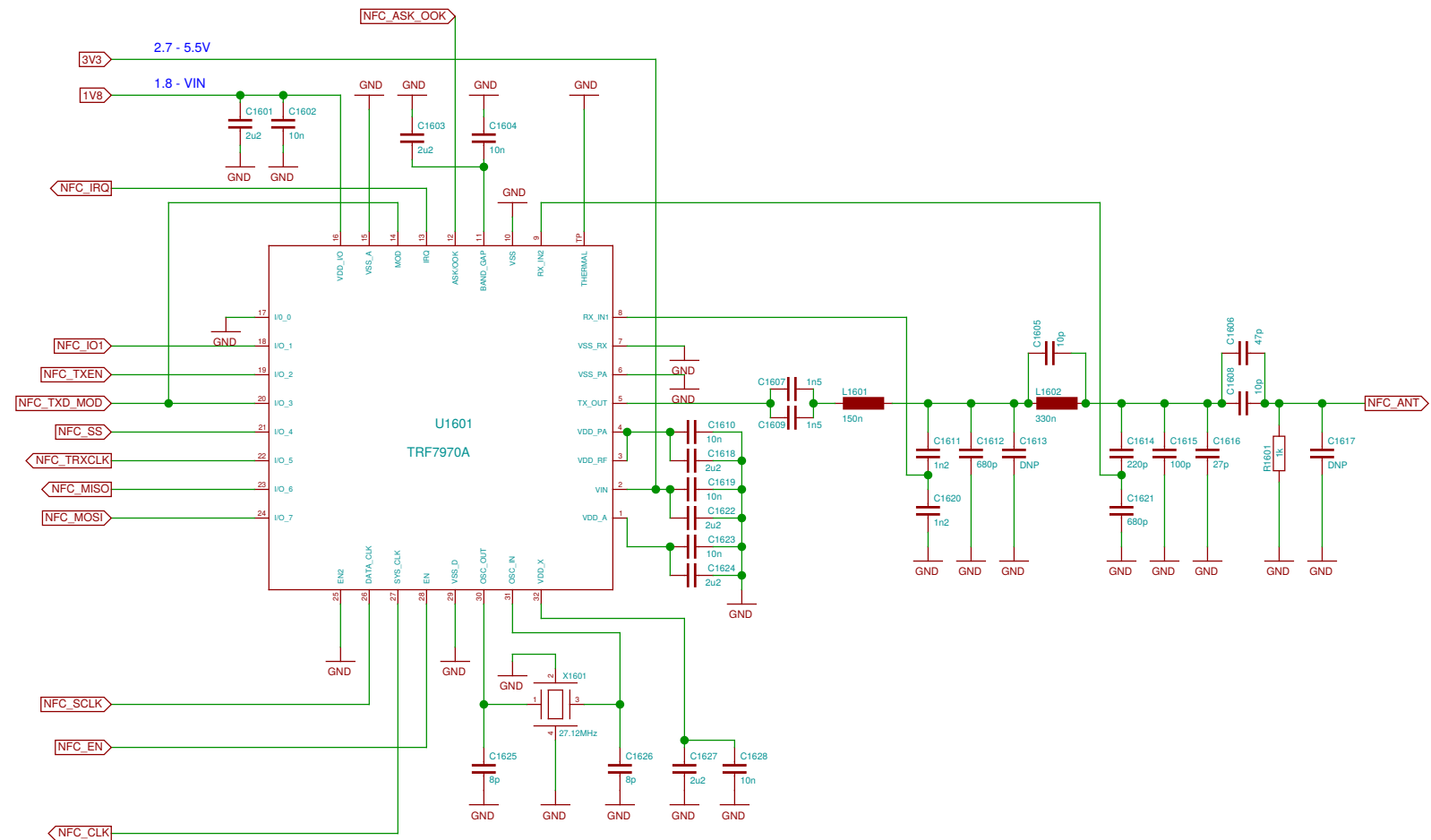

Some choices, 3.2 x 2.6 mm, 8-10 pF:  
 NDK NX3225GA-27.12M-STD-CRG-2  
 NDX NX3225SA-27.12M-STD-CSR-3  
 Tattien XXCCEINANF-27.120000



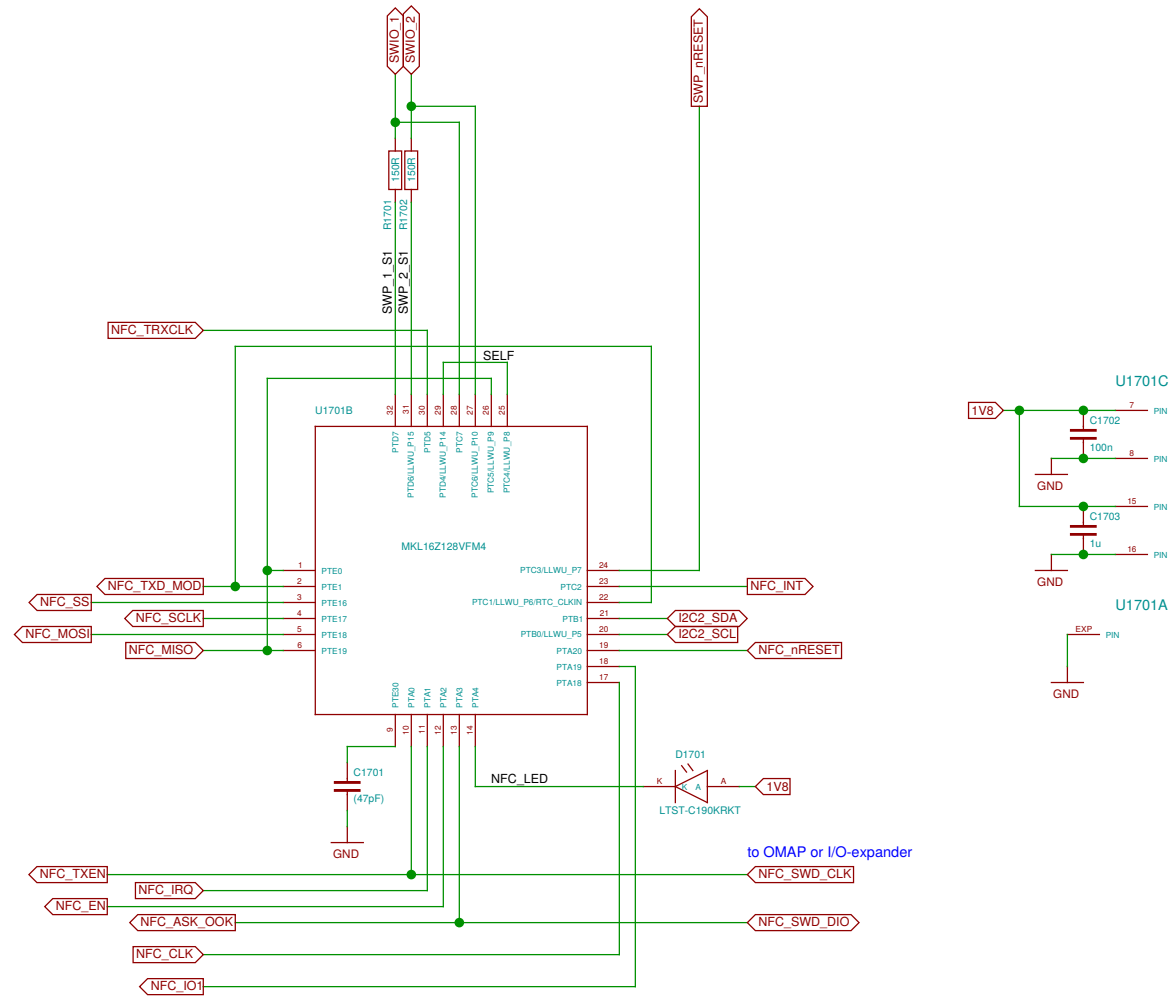

Sheet: /RFID/NFC Controller/ File: neo900_SS_17.sch	
Title: RFID/NFC Controller	
Size: A3	Date: 17 JUL 2016
Plotted by: eeshow 14908eb+ 20160930-18:22Z	Rev: 17/37

NOTE: this is mangling up Breakout and Lower board connectors  
Signals may have to be fed through the breakout board connector increasing resistance

**TODO: align with HB WP**



**TODO: HB "base circuit" (level shifters, USB PHY, etc.) goes here**

Missing 10 level shifter chip (or do we really have the space for 10x discrete T+R+D ca. 3x3mm each?)

Missing 6x 2R for alternate function select (do we have the space for ca. 2.5 x 5mm?)

Sheet: /Hackerbus/ File: neo900_SS_18.sch		
Title: Hackerbus		
Size: A3	Date: 17 JUL 2016	Rev:
Plotted by eeshow 14908eb+ 20160930-18:22Z		Id: 18/37

# TODO: update D1901 footprint

NOTE: 1V8 may be quite noisy

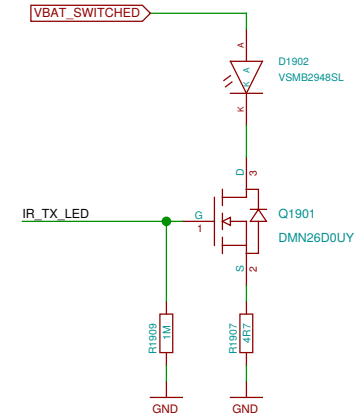
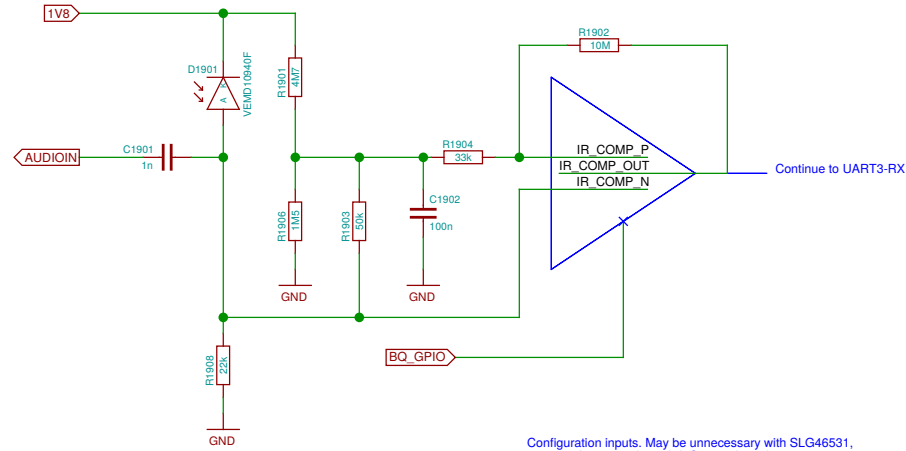

Configuration inputs. May be unnecessary with SLG46531, once configuration through I2C is confirmed.

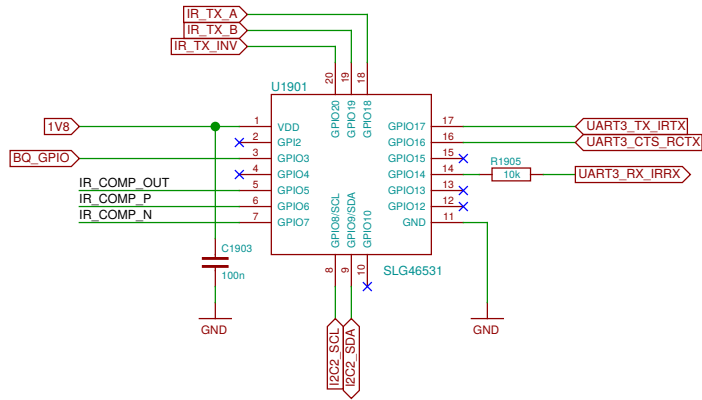

# TODO: update when details settle

ca. 130 signals (to be counted exactly after definition of upper/lower split)

- MMCS-DATA1/9.1A
- MMCS-DATA2/9.1A
- MMCS-DATA3/9.1A
- GPIO-WLAN-IRQ/9.1A
- GPIO-BT-EN/9.1C
- UART1-RX/9.1C
- UART1-RTS/9.1C
- UART1-CTS/9.1D
- UART1-TX/9.1D
- MCBSP3-FCK/9.1D
- MCBSP3-CLK/9.1D
- MCBSP3-DR/9.1D
- MCBSP3-DX/9.1D
- SYSCLK/9.3C
- 32KHZ/9.4A
- GPIO-FM-EN/9.3A
- GPIO-FMIRQ/9.3A
- MCBSP2-FCK/9.3A
- MCBSP2-CLK/9.3A
- MCBSP2-DR/9.3A
- MCBSP2-DX/9.3A
- GPIN115/10.3B
- GPIO56/10.3A
- GPIO51/10.3B
- GPIO55/10.4A
- GPIO56/10.4A
- ACCEL-INT/10.4C
- NS129/11.2A
- NS148/11.1A
- NS149/11.1A
- NS150/11.1A
- NS153/11.1A
- NS154/11.1A
- GPIO-ECI1/13.3B
- GPIO-ECI0/13.3C
- ECI-ADC/13.3C
- VMMC2/12.1A
- GPIO-HP-EN/12.1B
- GPIO560/12.2D
- GPIO177/12.4C
- GPIO-HF-EN/14.1B
- GPIO-FLASH-STR/15.1A
- GPIO-FLASH-EN/15.1A
- GPIO-FLASH-INT/15.1A
- GPIO-BATT-LID/15.1B
- SD-CMD/15.2A
- SD-CLK/15.2A
- SD-CD/15.2B
- SD-VDD/15.2A
- SD-DAT0/15.2B
- SD-DAT1/15.2B
- SD-DAT2/15.2A
- SD-DAT3/15.2A
- VIB+/15.1D
- VIB-/15.1D
- 3V3/19.1D
- 2V5/13.3B
- 1V8/19.1D
- VBUS/18.1C
- OTG-D-/3.1B
- OTG-D+/3.1B
- OTG-ID/2.2B
- VBUS-MODEM/6.3B
- USB-WWAN-D+/18.3A
- USB-WWAN-D-/18.3A
- 2V7/8.4C
- GPIO-CAM-COVER/15.1B
- NS38
- LOCK-GPIO/1.2A
- POWERON/1.3A
- GPIO-VOL+/1.2B
- GPIO-VOL-/1.2B
- CAM1-GPIO/1.3B
- CAM2-GPIO/1.3C
- I2C3-SDA/10.4C
- I2C3-SCL/10.4C
- CHG\_IND/3.1B
- NS131/3.1C
- NS141/3.1C
- NS143/3.1C
- BATTEMP/5.4A
- GPIO-EN-MODEM/4.1A
- I2C2-SDA/15.1A
- I2C2-SCL/15.1A
- INA231-INT/4.4C
- HDO/5.2A
- GPIO570/8.3B
- GPIO5110/8.1D
- NS19/8.2D
- NS229/8.3C
- ADC5114/8.1C
- ADC1/8.4C
- ADC2/8.4C
- GPIO-COMPARATOR/8.4D
- MCBSP4-DR/6.2A
- MCBSP4-DX/6.2A
- MCBSP4-CLKX/6.2A
- MCBSP4-FSX/6.2A
- UART7-RTS/6.2C
- UART7-CTS/6.2C
- UART7-RX/6.2C
- UART7-TX/6.2C
- RING/6.2C
- GPIO-MODEM\_IGT/6.3A
- GPIO-MODEM\_EMERG/6.3A
- EMERG\_OFF/6.3B
- PWR\_IND/6.3B
- LC\_IND/6.3B
- STATUS/6.3B
- 3G-WOE/6.3B
- GPIO52/8.4A
- GPIO-WLAN-EN/9.1A
- MMC3-CLK/9.1A
- MMC3-CMD/9.1A
- MMC3-DATA0/9.1A

Pin assignment must be optimized for final component placement  
we might have to switch to 80 or 100 pin connectors

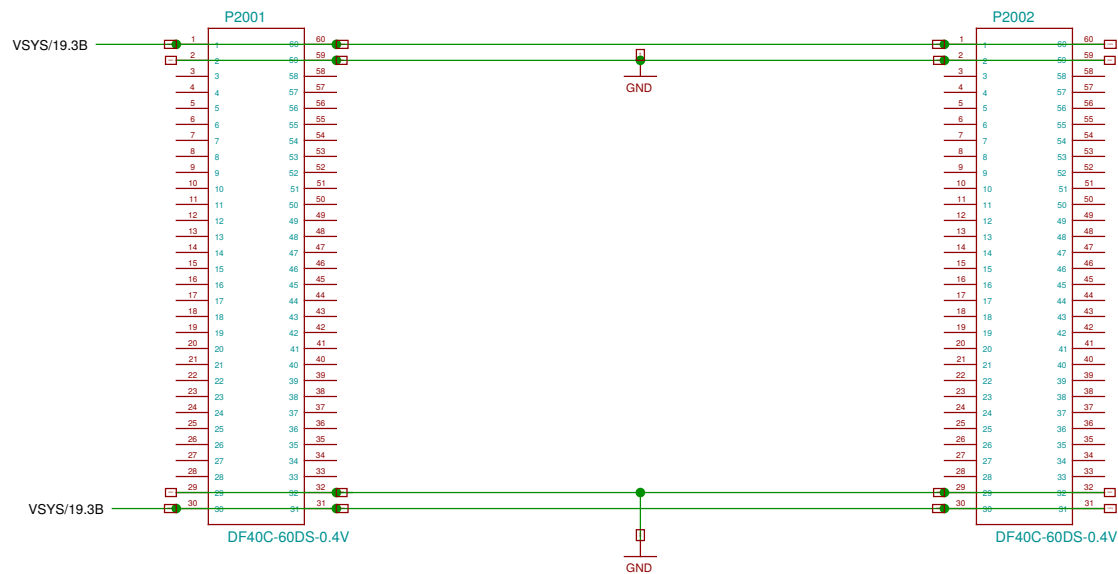

# TODO: add ESD protection (here)

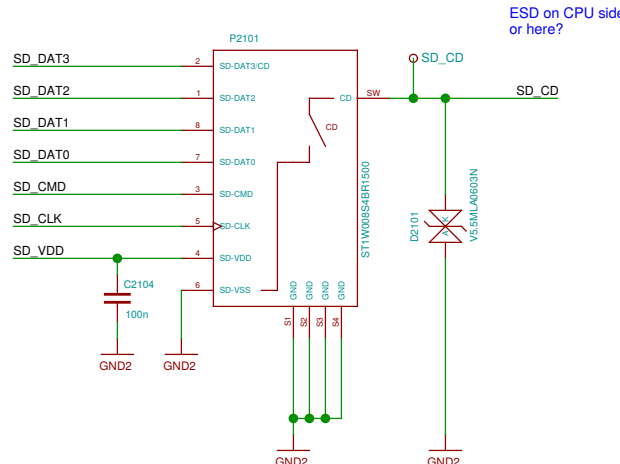
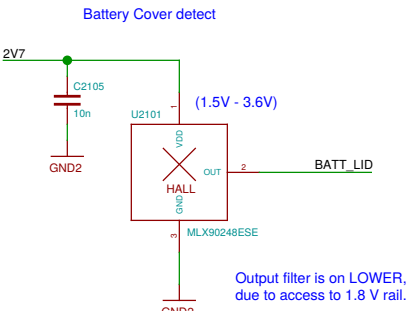
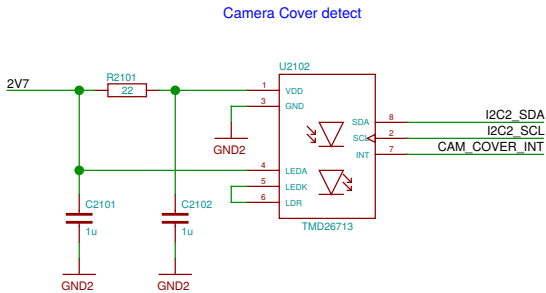

The LOWER\_BOB interconnect is defined in the Hackabus specification <http://neo900.org/stuff/papers/hb.pdf>

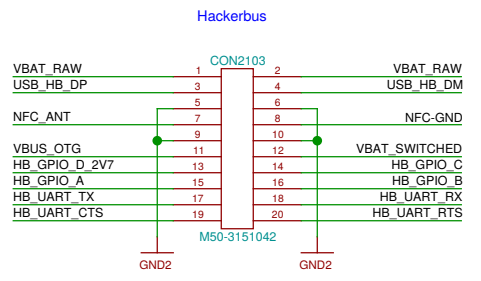
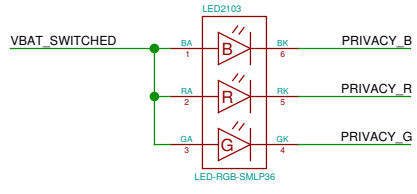
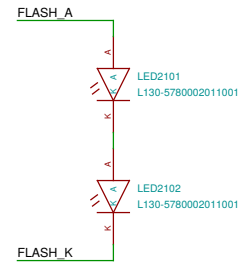
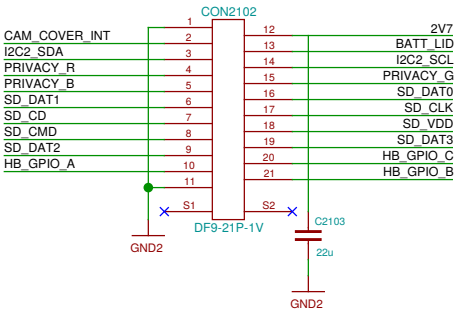
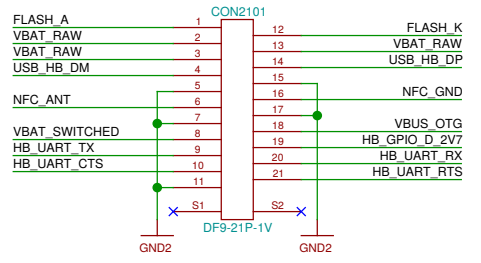

# TODO: track B2B to UPPER



to be adjusted to lower board connector

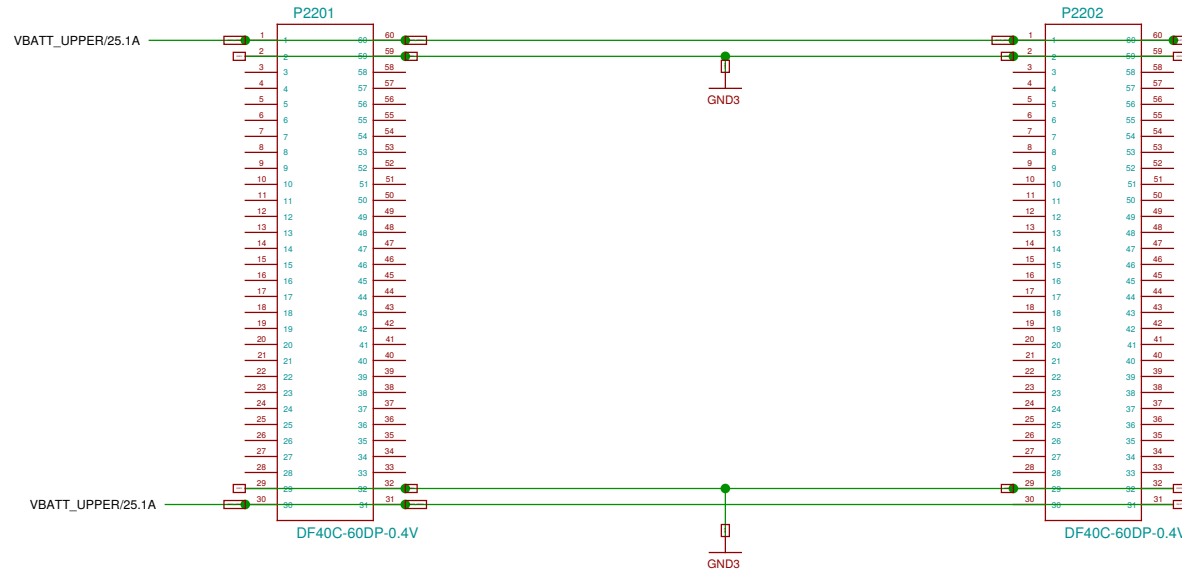

## SHIELD

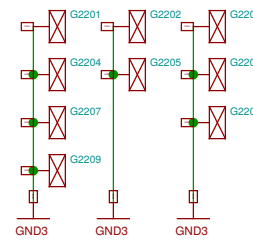

# TODO: \*\_UPPER names ?

needs final tuning (which button on which position)  
 VOL+ and VOL- could drive FETs sitting in the matrix

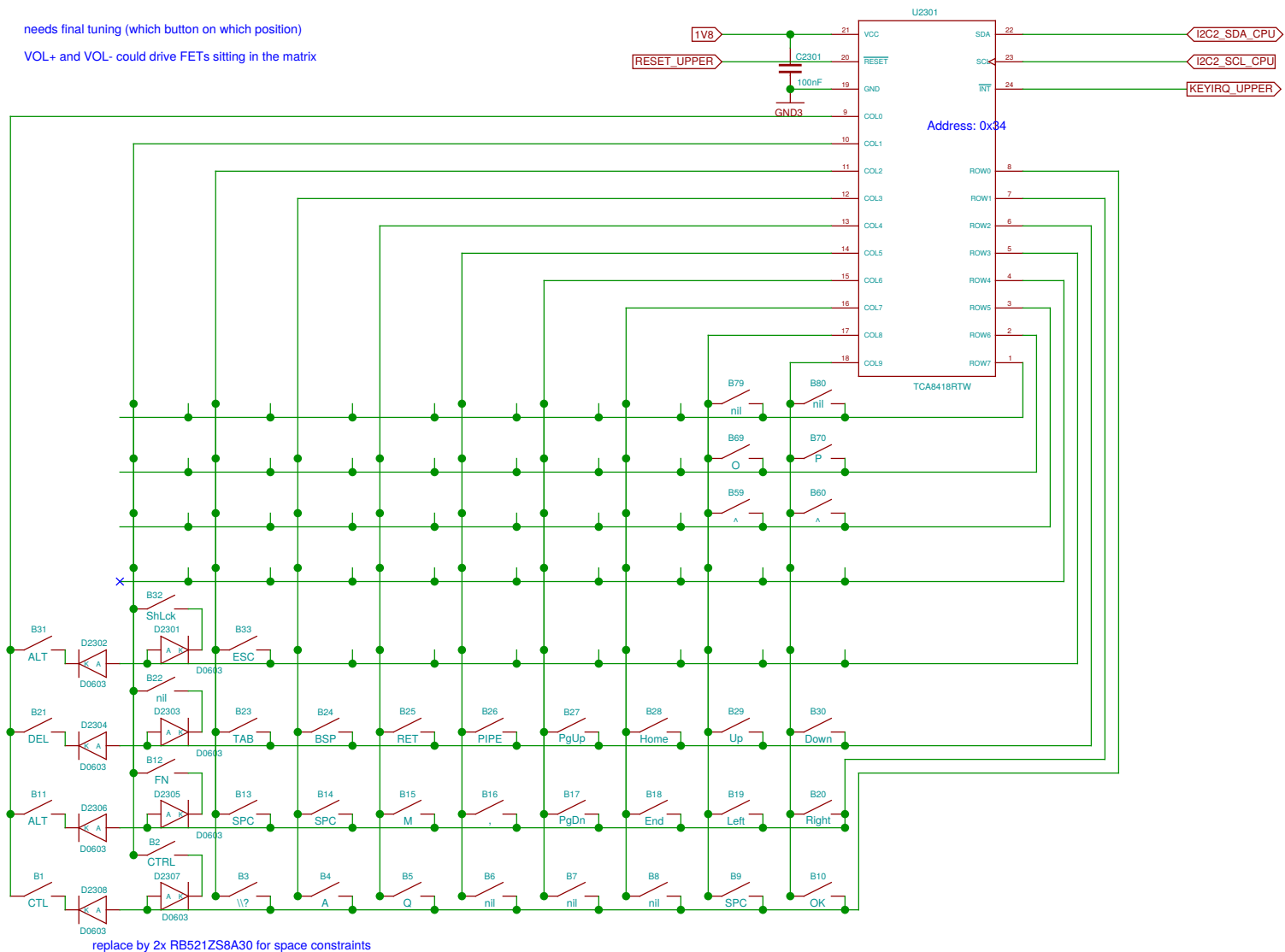

- TODO: key names are nonsense
- TODO: sort out 6 "ext" buttons
- TODO: rearrange matrix to avoid diodes ?

Resistive Touch (display connector)

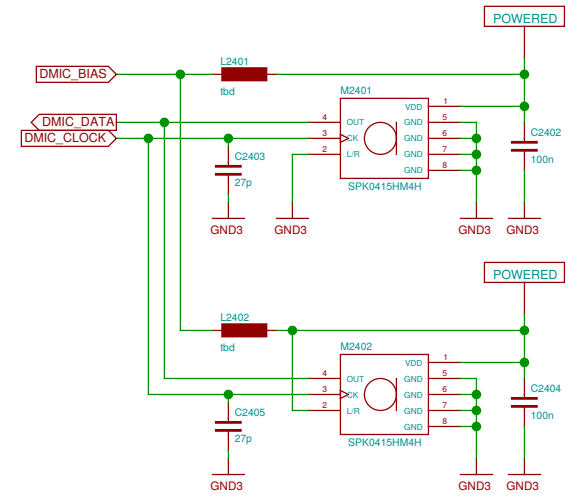
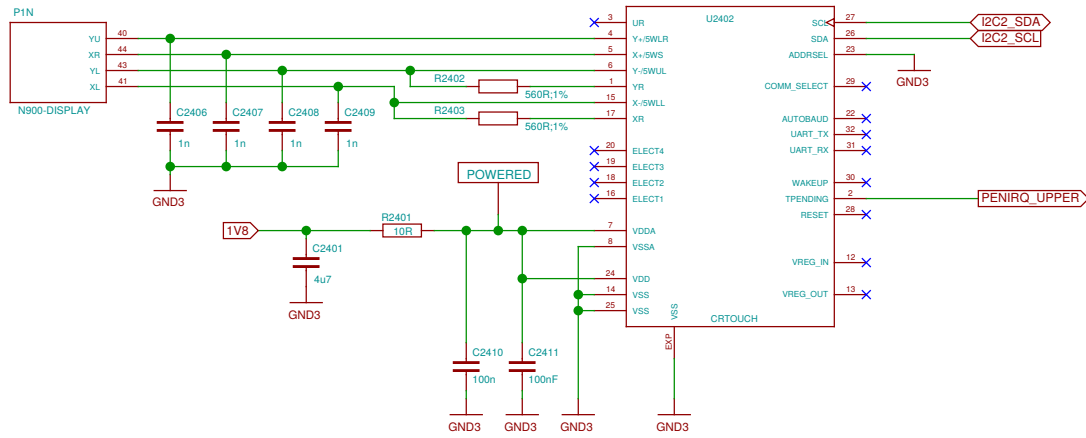



# TWL4030, GPIO6/PWM0, ball M4

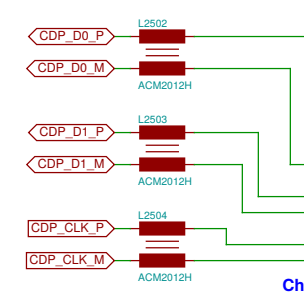
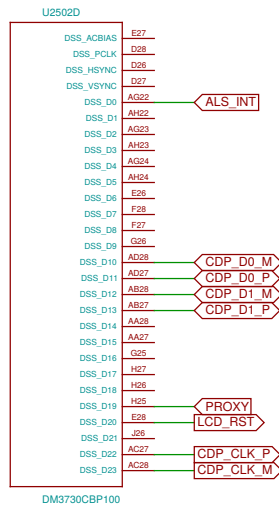
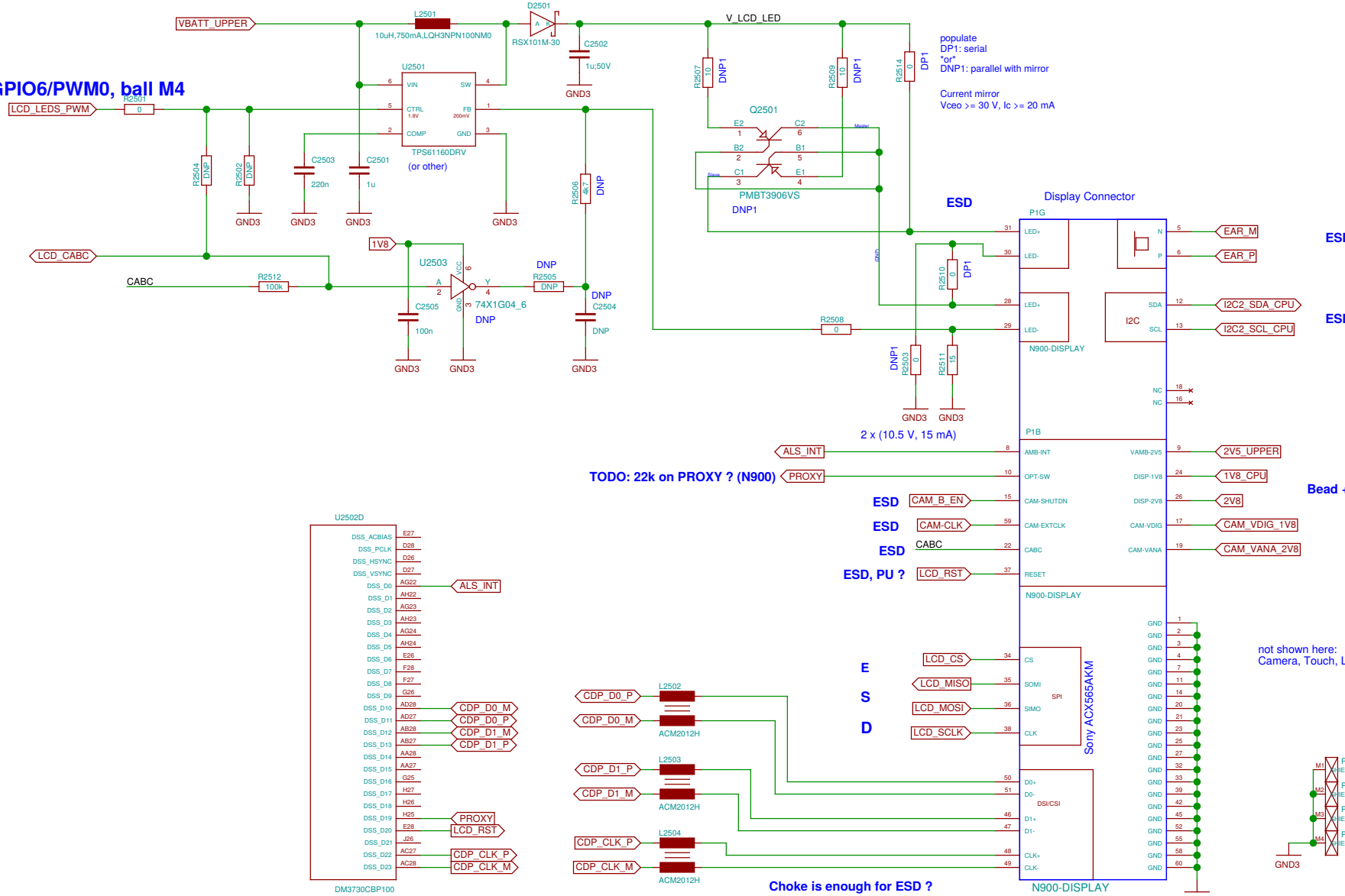

INCOMPLETE in V2

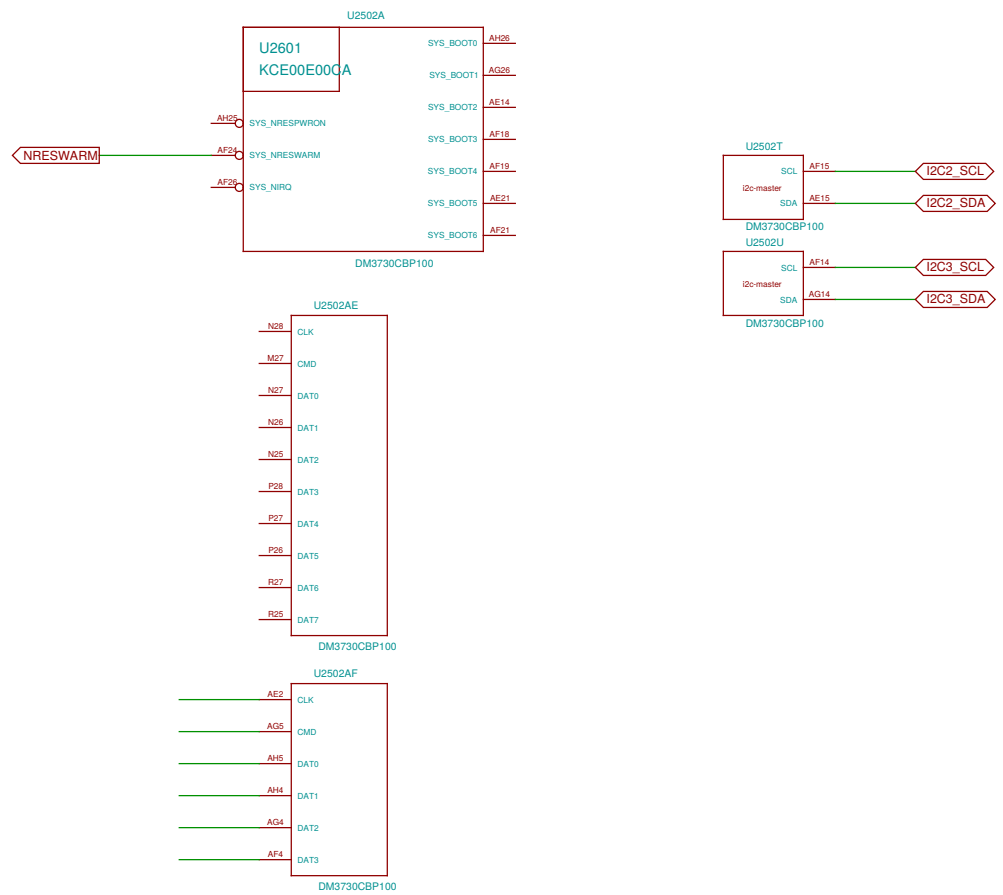

Sheet: /CPU + PoP RAM/NAND/ File: neo900_SS_26.sch		
Title: CPU + PoP RAM/NAND		
Size: A3	Date: 17 JUL 2016	Rev:
Plotted by eeshow 14908eb+ 20160930-18:22Z		Id: 26/37

INCOMPLETE in V2

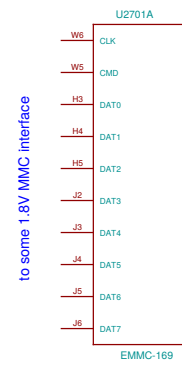
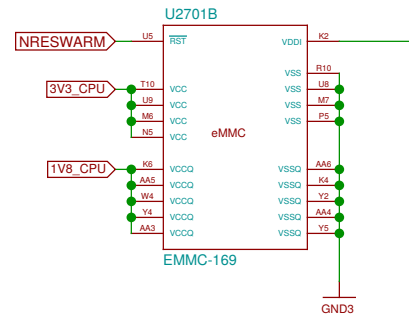

Sheet: /eMMC/		Date: 17 JUL 2016		Rev:	
File: neo900_SS_27.sch		Plotted by eeshow 14908eb+ 20160930-18:22Z		Id: 27/37	
Title: eMMC					
Size: A3	Date: 17 JUL 2016				

# TODO: check role

INCOMPLETE in V2

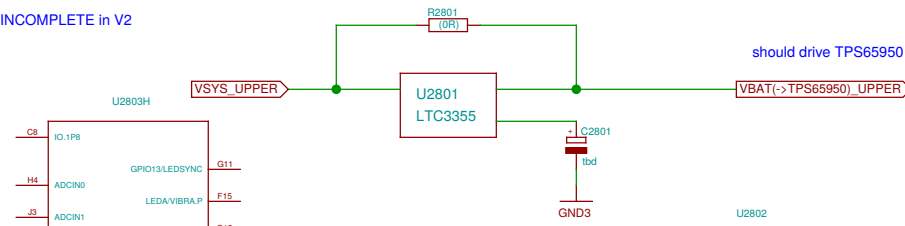

should drive TPS65950

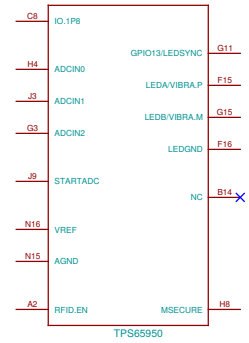

this goes through B2B to OTG socket

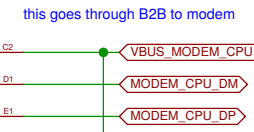
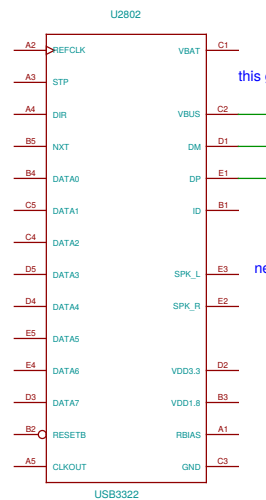
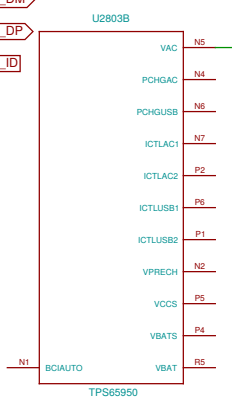

needs a small charge pump to generate 5V 50mA.

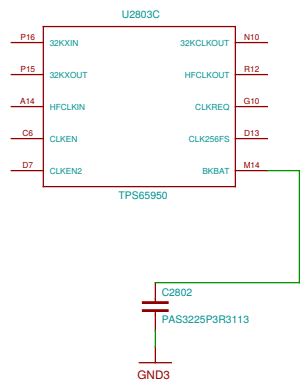

# TODO: VBUS-MODEM ?

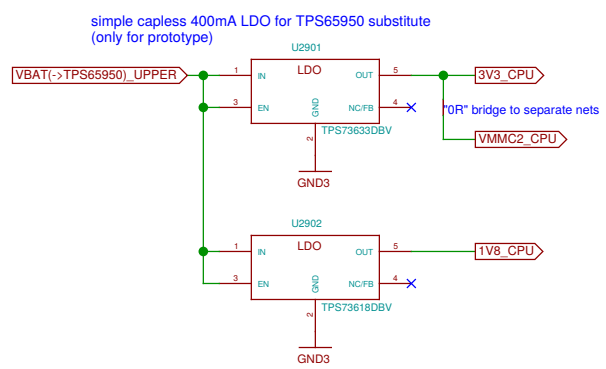

Sheet: /BB-XM Dummy (TWL4030)/		
File: neo900_SS_29.sch		
Title: BB-XM Dummy (TWL4030)		
Size: A3	Date: 17 JUL 2016	Rev:
Plotted by eeshow 14908eb+ 20160930-18:22Z		Id: 29/37

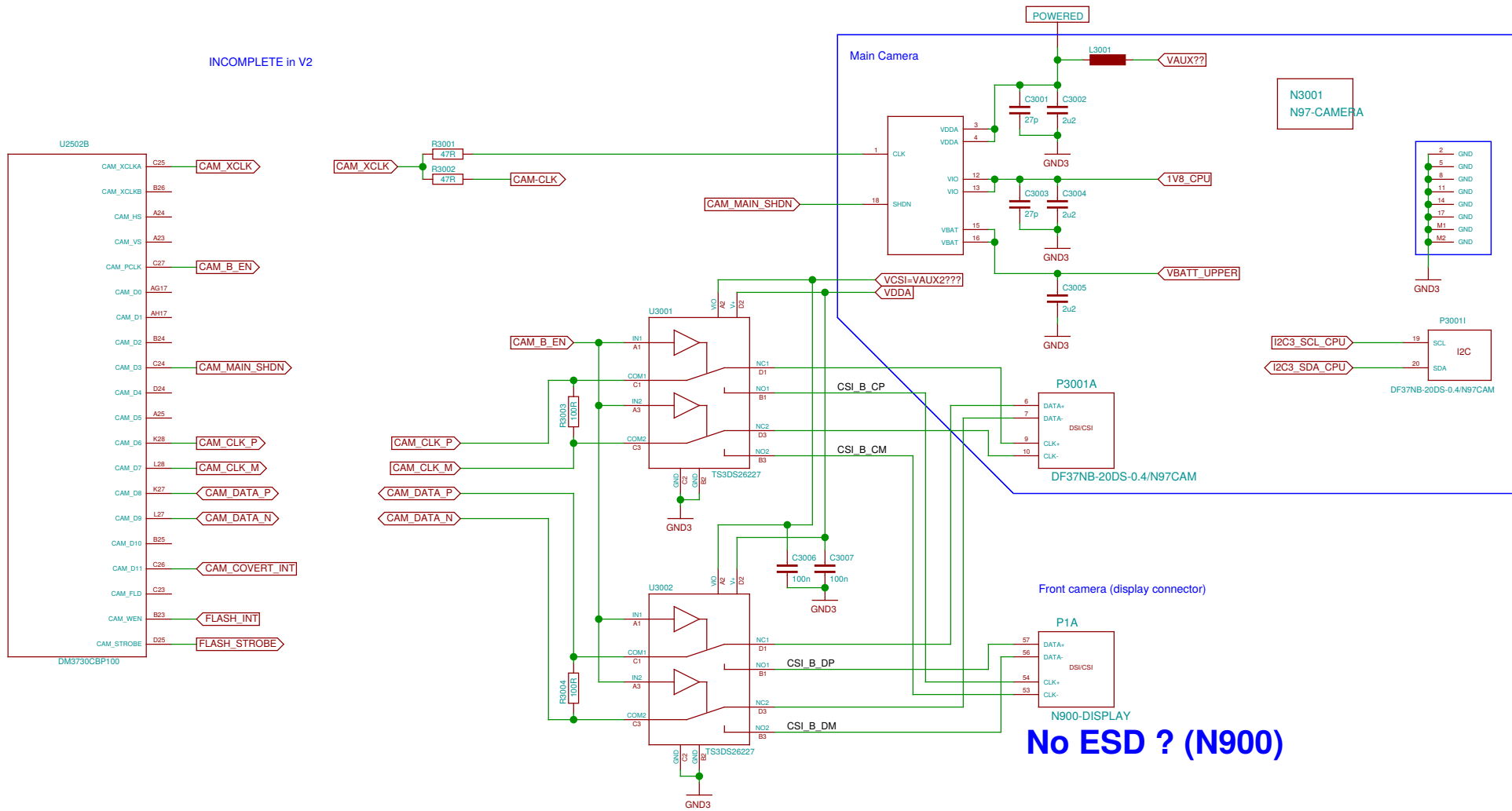

INCOMPLETE in V2

No ESD ? (N900)

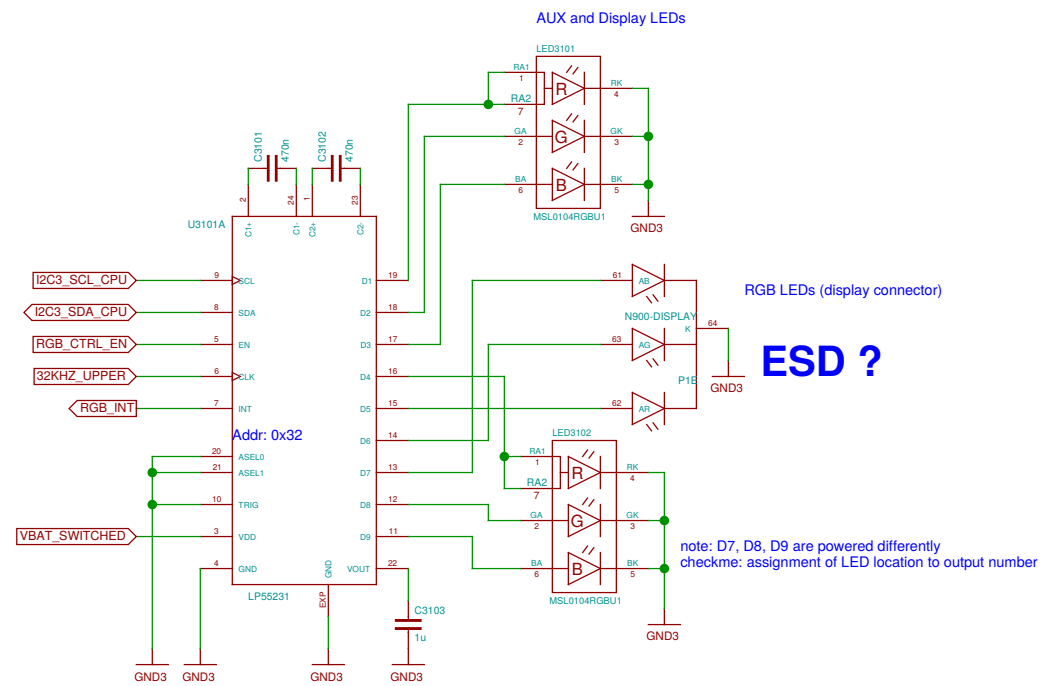

**TODO: LEDs/Fancy LEDs sheets have title swapped**

Sheet: /LEDs/ File: neo900_SS_31.sch	
Title: LEDs	
Size: A3	Date: 17 JUL 2016
Plotted by: eeshow 14908eb+ 20160930-18:22Z	Rev: Id: 31/37

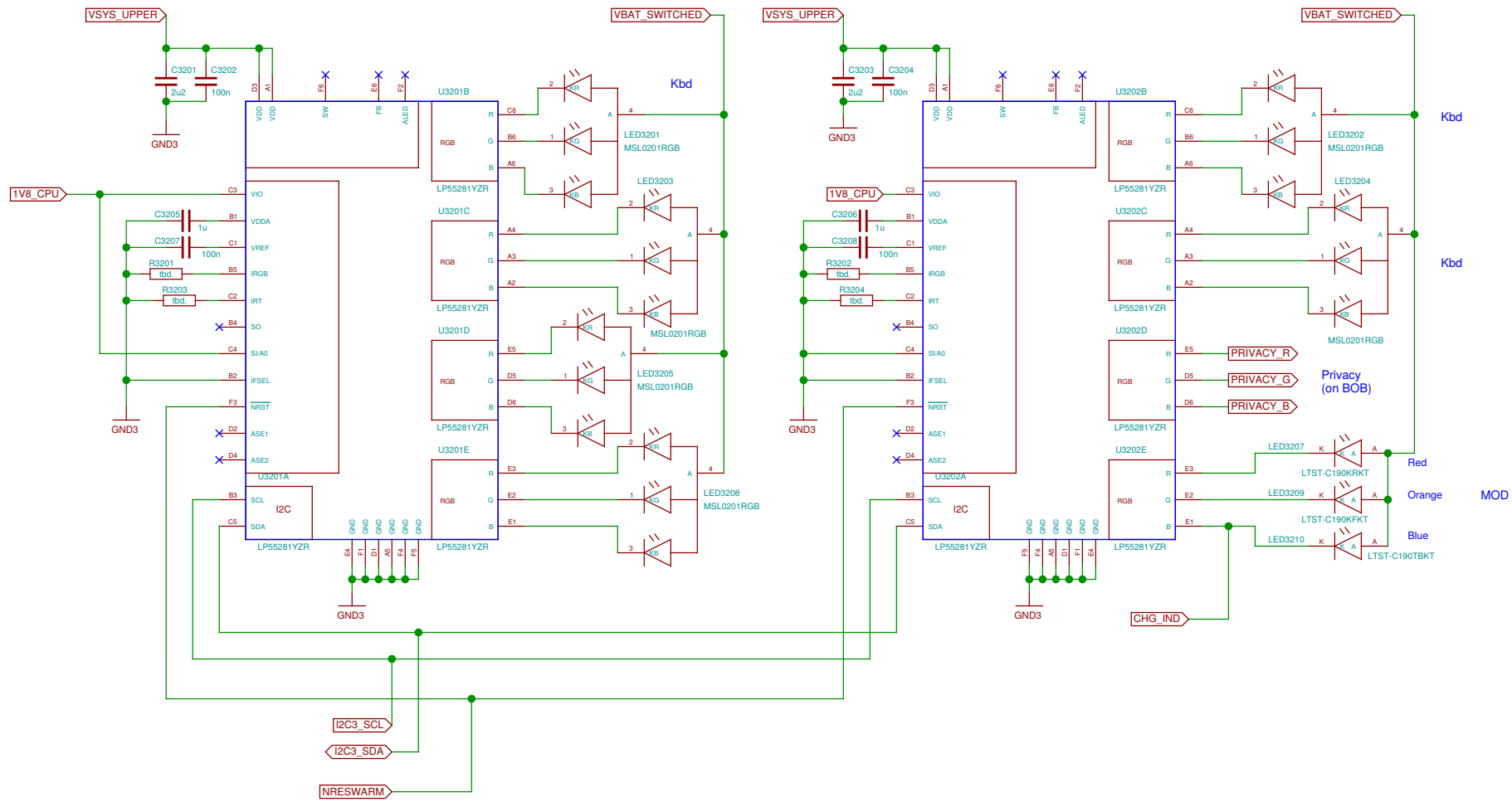



These connectors allow to "emulate" the DM3730 by connecting a BB-XM

INCOMPLETE  
prototype only

Connect to OMAP3 McSPI1, I2C2, MMC2 / some GPIOs

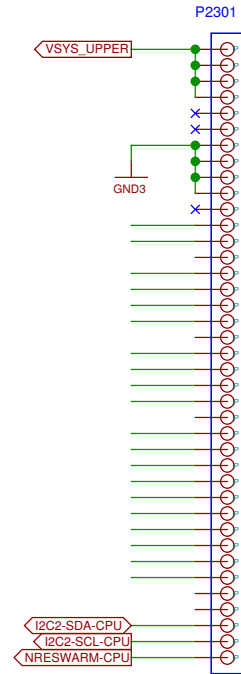

connect to respective CPU-pads

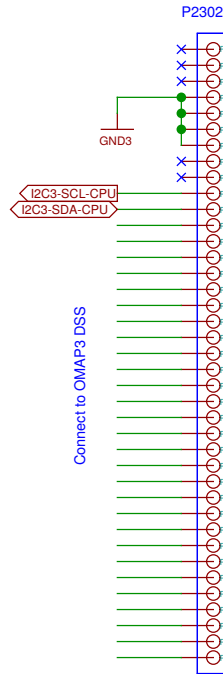

Connect to OMAP3 DSS

DSS / GPIOs, I2C3

Connect to OMAP3 Camera

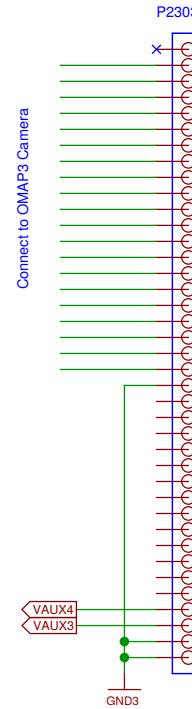

connect to BB  
by some Micro-USB cable

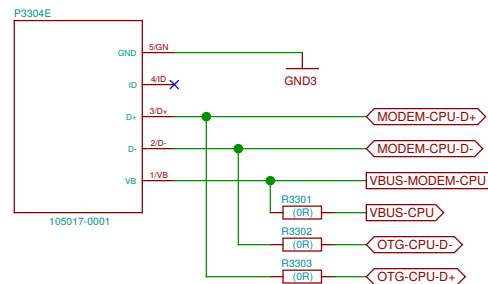

**TODO: VBUS-MODEM ?**

Sheet: /Connector to BB-XM/ File: neo900_SS_33.sch	
Title: Connector to BB-XM	
Size: A3	Date: 17 JUL 2016
Plotted by eeshow 14908eb+ 20160930-18:22Z	Rev: Id: 33/37

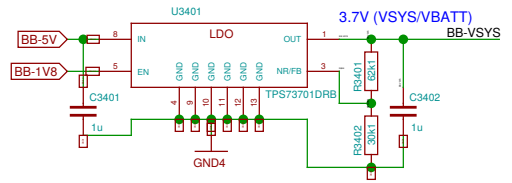

Ersetzen durch 2A buck converter

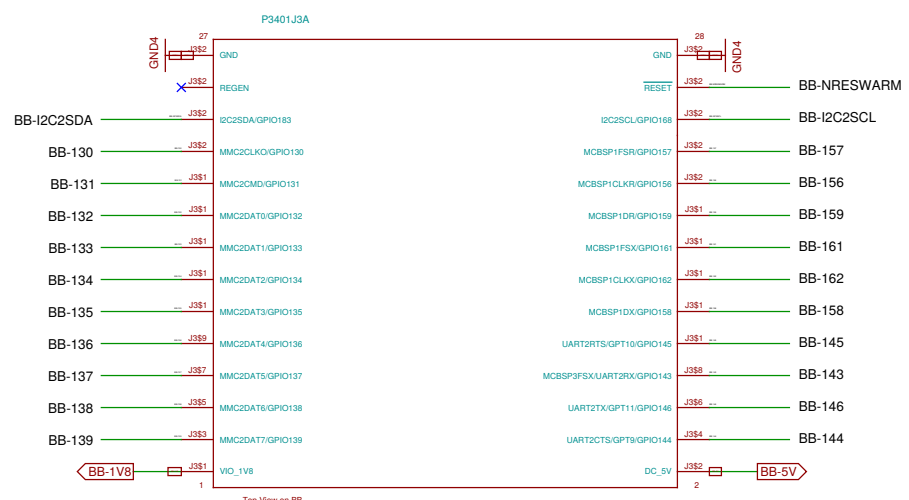
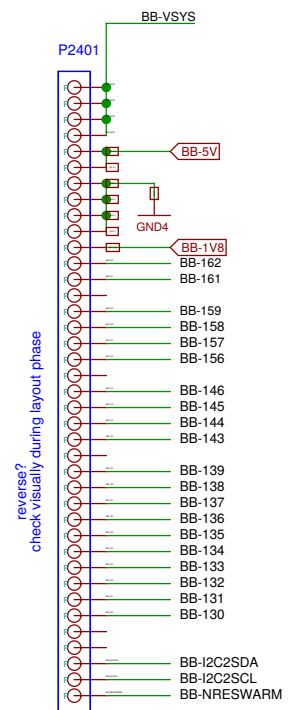

BB-xM Main Expansion Header (7.24)

**TODO: needs decision on where to take this**

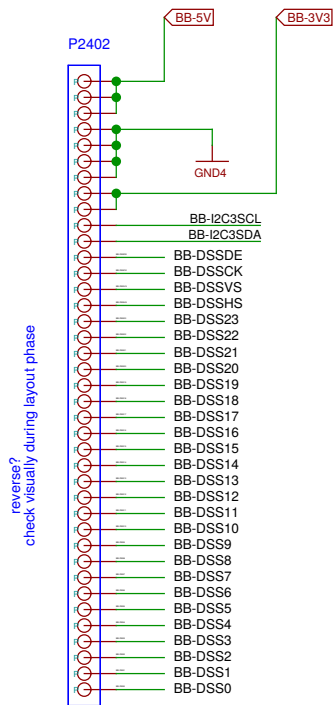

reverse?  
check visually during layout phase

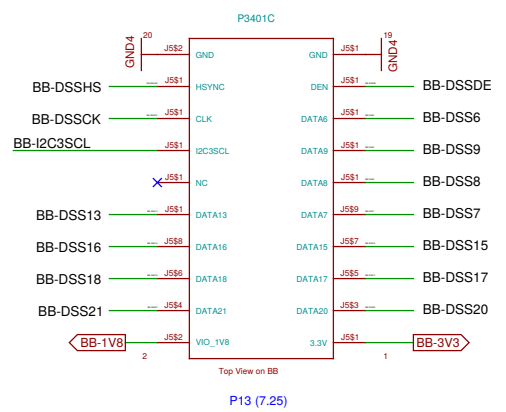
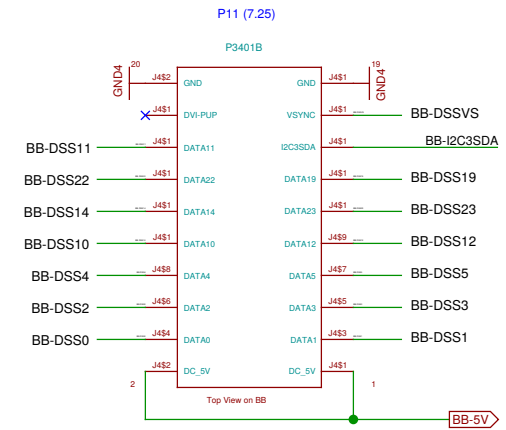

**TODO: needs decision on where to take this**

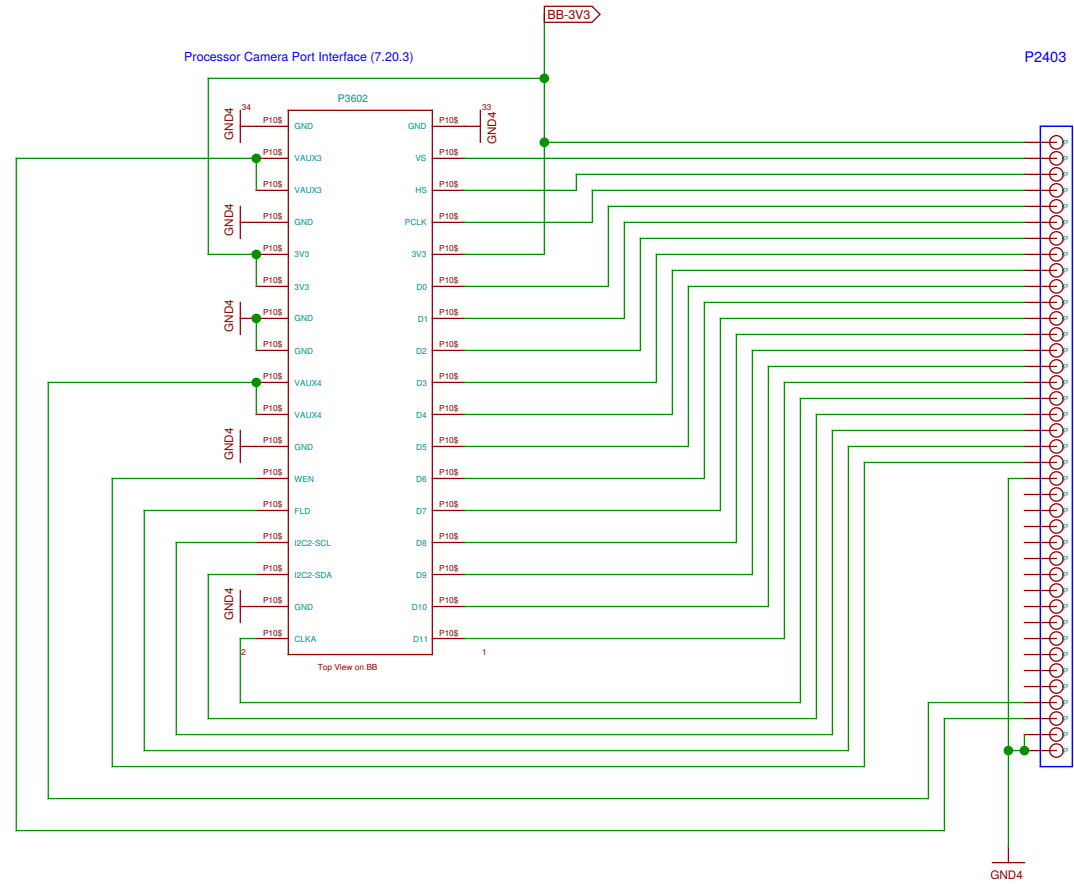

reverse?  
check visually during layout phase

Sheet: /BB-XM Adapter (CAM)/		
File: neo900_SS_36.sch		
Title: BB-XM Adapter (CAM)		
Size: A3	Date: 17 JUL 2016	Rev:
Plotted by eeshow 14908eb+ 20160930-18:22Z		Id: 36/37

Molex Jumper cables to connect BB-XM-Adapter to Uppwer board

N3701 15015-0439	N3702 15015-0439	N3703 15015-0439
CPU	DISP	CAM

N3704 N900 case assembly
-----------------------------

N3705 N97-CAMERA-HOLE
--------------------------

N3706 headset jack
-----------------------

N3707 STENCIL-TOP
----------------------

N3708 STENCIL-BOTTOM
-------------------------

Sheet: /No-Solder Components/ File: neo900_SS_37.sch		
Title: No-Solder Components		
Size: A3	Date: 17 JUL 2016	Rev:
Plotted by eeshow 14908eb+ 20160930-18:22Z		Id: 37/37