

Click | Here

This sheet: [index](#)

[Sheet: OTG](#)  
File: neo900\_SS\_2.sch  
**OTG & Switches**

[Sheet: Charger/OTG-Booster](#)  
File: neo900\_SS\_3.sch  
**Charger/OTG-Booster**

[Sheet: Modem Power](#)  
File: neo900\_SS\_4.sch  
**Modem Power**

[Sheet: Fuel Gauge](#)  
File: neo900\_SS\_5.sch  
**Fuel Gauge**

[Sheet: 3G/4G Modem + SIM](#)  
File: neo900\_SS\_6.sch  
**3G/4G Modem + SIM**

[Sheet: Dual SIM switch](#)  
File: neo900\_SS\_7.sch  
**Dual SIM switch**

[Sheet: Antenna connections](#)  
File: neo900\_SS\_8.sch  
**Antenna connections**

[Sheet: WLAN, Bluetooth, FM](#)  
File: neo900\_SS\_9.sch  
**WLAN, Bluetooth, FM**

[Sheet: Sensors](#)  
File: neo900\_SS\_10.sch  
**Sensors**

[Sheet: Audio Codec](#)  
File: neo900\_SS\_11.sch  
**Audio Codec**

[Sheet: Audio Headset + Mic](#)  
File: neo900\_SS\_12.sch  
**Audio Headset + Mic**

[Sheet: ECI](#)  
File: neo900\_SS\_13.sch  
**ECI**

[Sheet: Audio Handsfree](#)  
File: neo900\_SS\_14.sch  
**Audio Handsfree**

[Sheet: Misc](#)  
File: neo900\_SS\_15.sch  
**Misc**

[Sheet: RFID/NFC Reader](#)  
File: neo900\_SS\_16.sch  
**RFID/NFC Reader**

[Sheet: RFID/NFC Controller](#)  
File: neo900\_SS\_17.sch  
**RFID/NFC Controller**

[Sheet: Hackerbus](#)  
File: neo900\_SS\_18.sch  
**Hackerbus**

[Sheet: Infrared](#)  
File: neo900\_SS\_19.sch  
**Infrared**

[Sheet: B2B to UPPER](#)  
File: neo900\_SS\_20.sch  
**B2B to UPPER**

[Sheet: uSD Breakout Board](#)  
File: neo900\_SS\_21.sch  
**uSD Breakout Board**

[Sheet: B2B to LOWER](#)  
File: neo900\_SS\_22.sch  
**B2B to LOWER**

[Sheet: Keypad](#)  
File: neo900\_SS\_23.sch  
**Keypad**

[Sheet: Display-Peripherals](#)  
File: neo900\_SS\_24.sch  
**Display-Peripherals**

[Sheet: Display-Panel&Power](#)  
File: neo900\_SS\_25.sch  
**Display-Panel&Power**

Click | Here

[Sheet: CPU + PoP RAM/NAND](#)  
File: neo900\_SS\_26.sch  
**CPU + PoP RAM/NAND**

[Sheet: eMMC](#)  
File: neo900\_SS\_27.sch  
**eMMC**

[Sheet: PMU+Codec](#)  
File: neo900\_SS\_28.sch  
**PMU+Codec**

[Sheet: BB-XM Dummy \(TWL4030\)](#)  
File: neo900\_SS\_29.sch  
**BB-XM Dummy (TWL4030)**

[Sheet: Camera](#)  
File: neo900\_SS\_30.sch  
**Camera**

[Sheet: Fancy LEDs](#)  
File: neo900\_SS\_31.sch  
**Fancy LEDs**

[Sheet: Basic LEDs](#)  
File: neo900\_SS\_32.sch  
**Basic LEDs**

[Sheet: Connector to BB-XM](#)  
File: neo900\_SS\_33.sch  
**Connector to BB-XM**

[Sheet: BB-XM Adapter \(CPU\)](#)  
File: neo900\_SS\_34.sch  
**BB-XM Adapter (CPU)**

[Sheet: BB-XM Adapter \(DISP\)](#)  
File: neo900\_SS\_35.sch  
**BB-XM Adapter (DISP)**

[Sheet: BB-XM Adapter \(CAM\)](#)  
File: neo900\_SS\_36.sch  
**BB-XM Adapter (CAM)**

[Sheet: No-Solder Components](#)  
File: neo900\_SS\_37.sch  
**No-Solder Components**

Note regarding I2C addresses:  
Addresses in the schematics are provided for convenience.  
The authoritative source is  
<https://neo900.org/git?p=misc;a=tree;f=i2c>

Sheet: /		
File: neo900.sch		
Title: Neo900		
Size: A3	Date: 16 JUL 2016	Rev:
Plotted by eeshow 14908eb+ 20160930-18:22Z		Id: 1/37

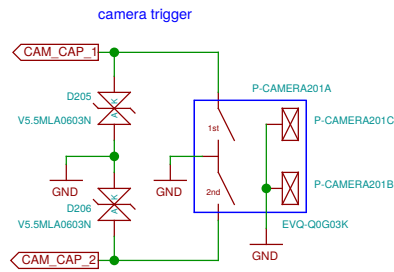
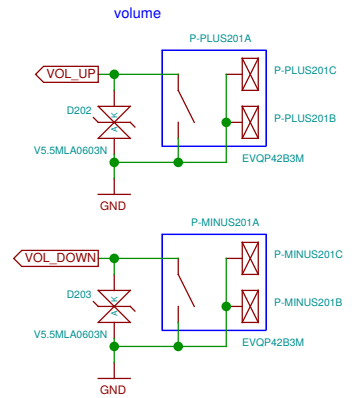
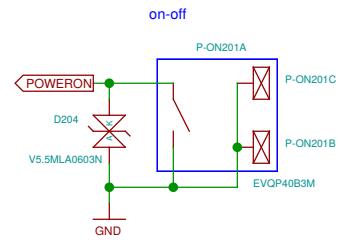
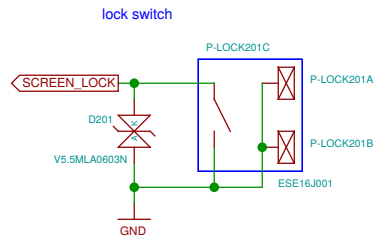

can be used to test/operate the modem through the OTG port (w/o UPPER PCB)

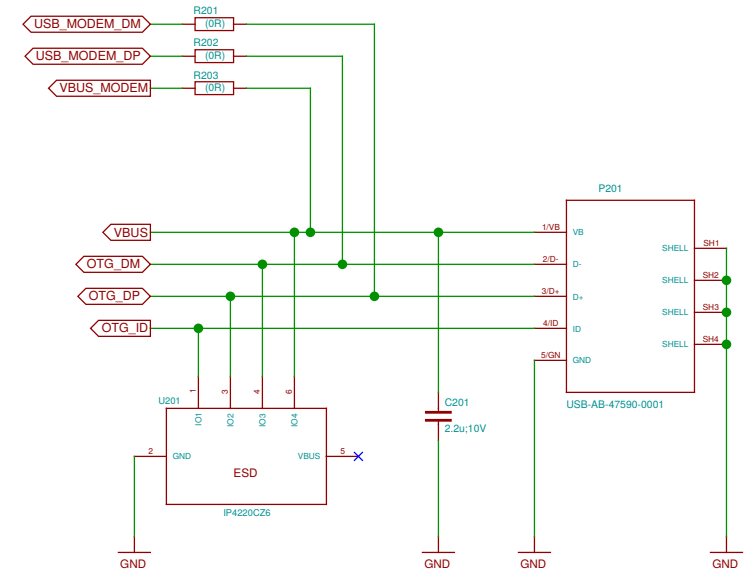

place in scan matrix? would need 3-4 wires to UPPER board instead of 2

in any case it is sufficient to connect GPIO-VOL+ and VOL- to two pins on the B2B connector

TODO: VBAT\_SWITCHED, with 1V8 as "enable"

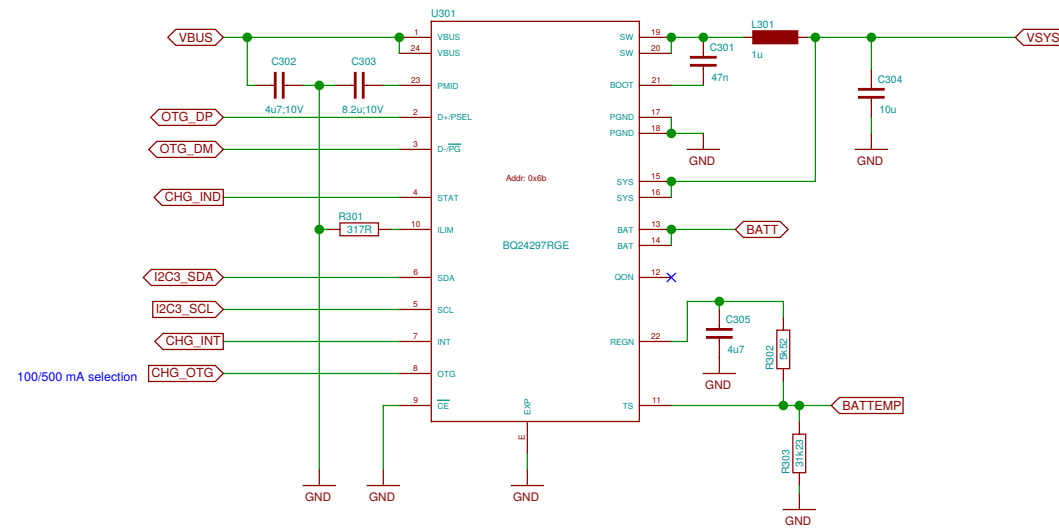

Sheet: /Charger/OTG-Booster/ File: neo900_SS_3.sch		
Title: Charger/OTG-Booster		
Size: A3	Date: 17 JUL 2016	Rev:
Plotted by eeshow 14908eb+ 20160930-18:22Z		Id: 3/37

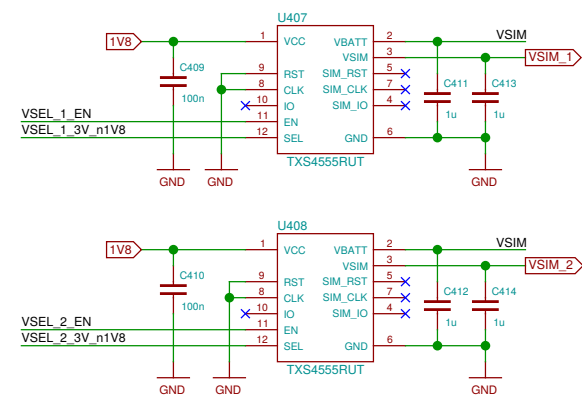
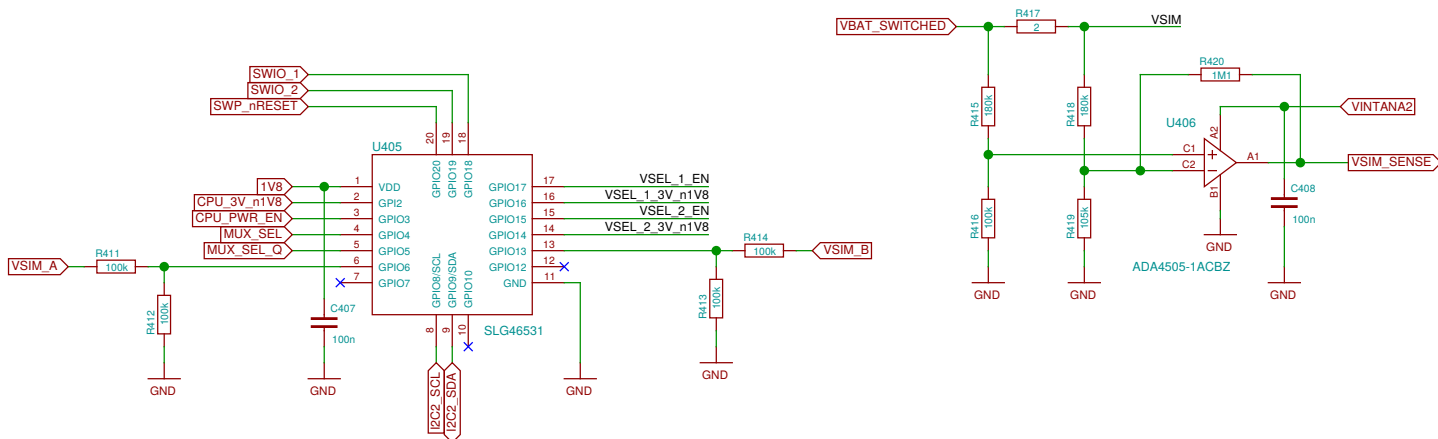
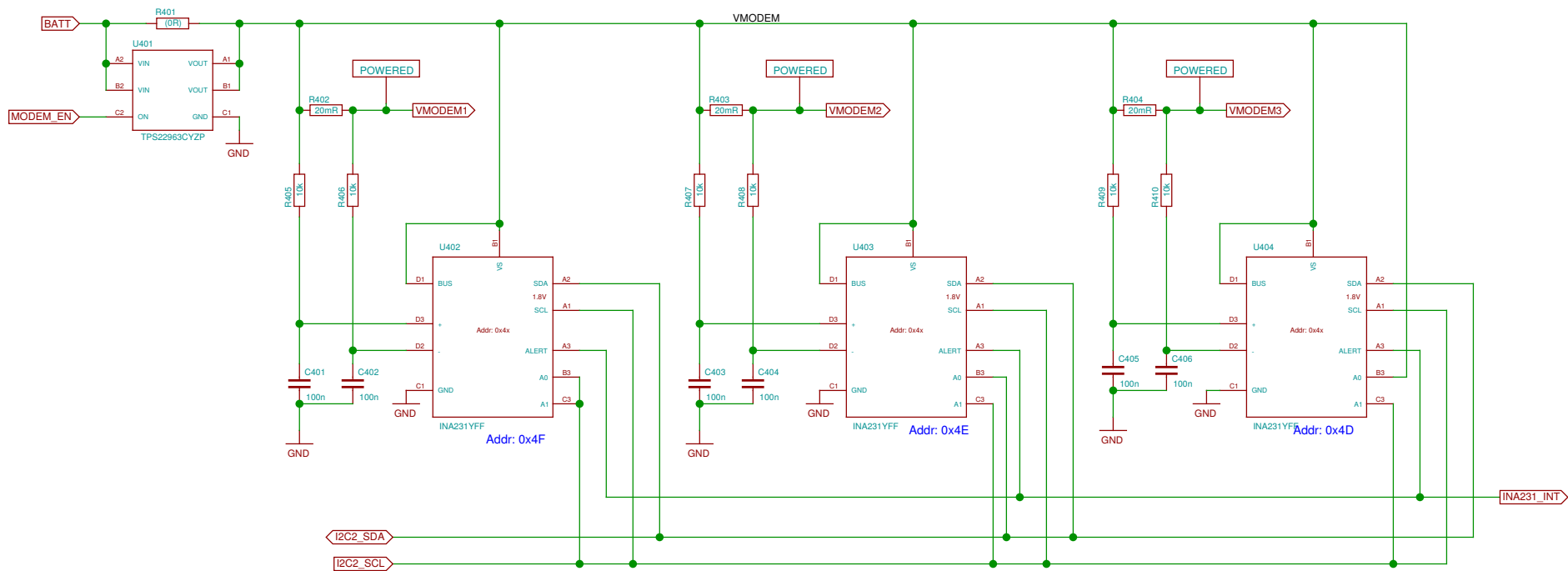

**TODO: update SLG design for changed pins**

TODO: does BATTID go to UPPER, too ?

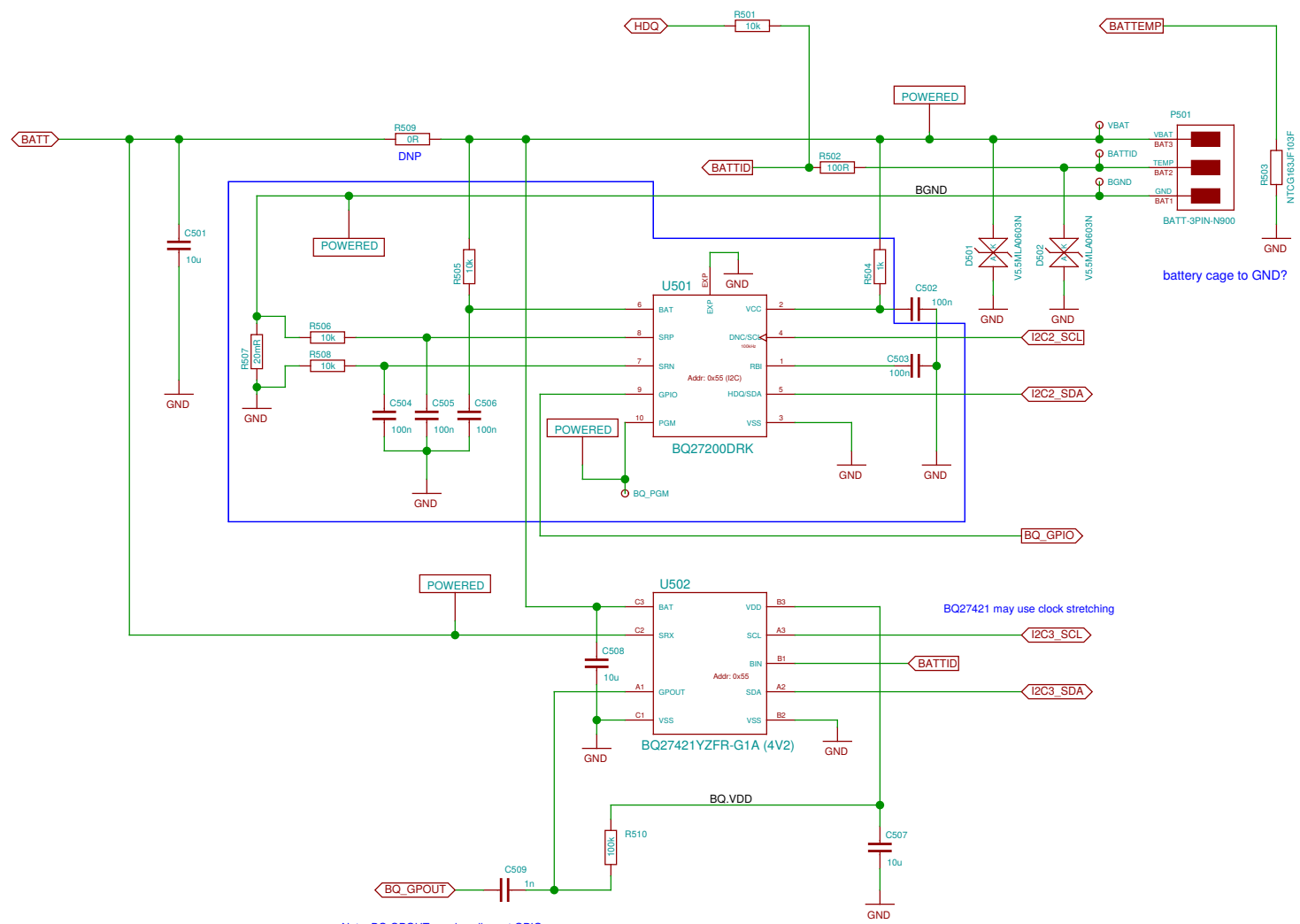

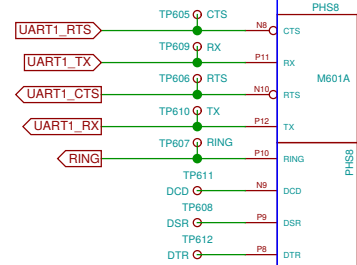
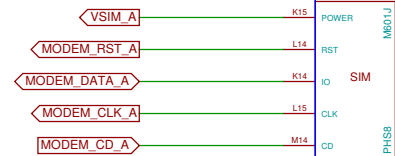
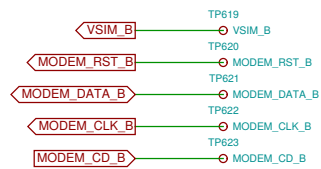
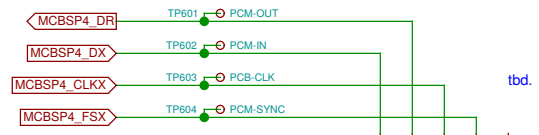
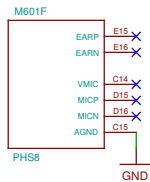

# TODO: B-SIM bus FFS

Can we connect UART in parallel to Bluetooth UART (i.e. if BT is disabled we can unbrick the Modem?)

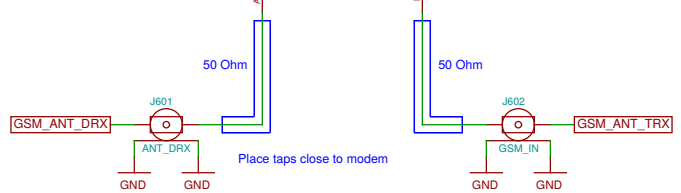
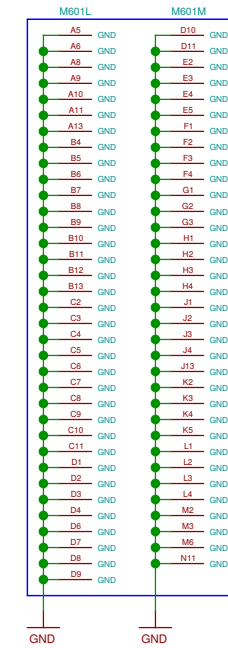
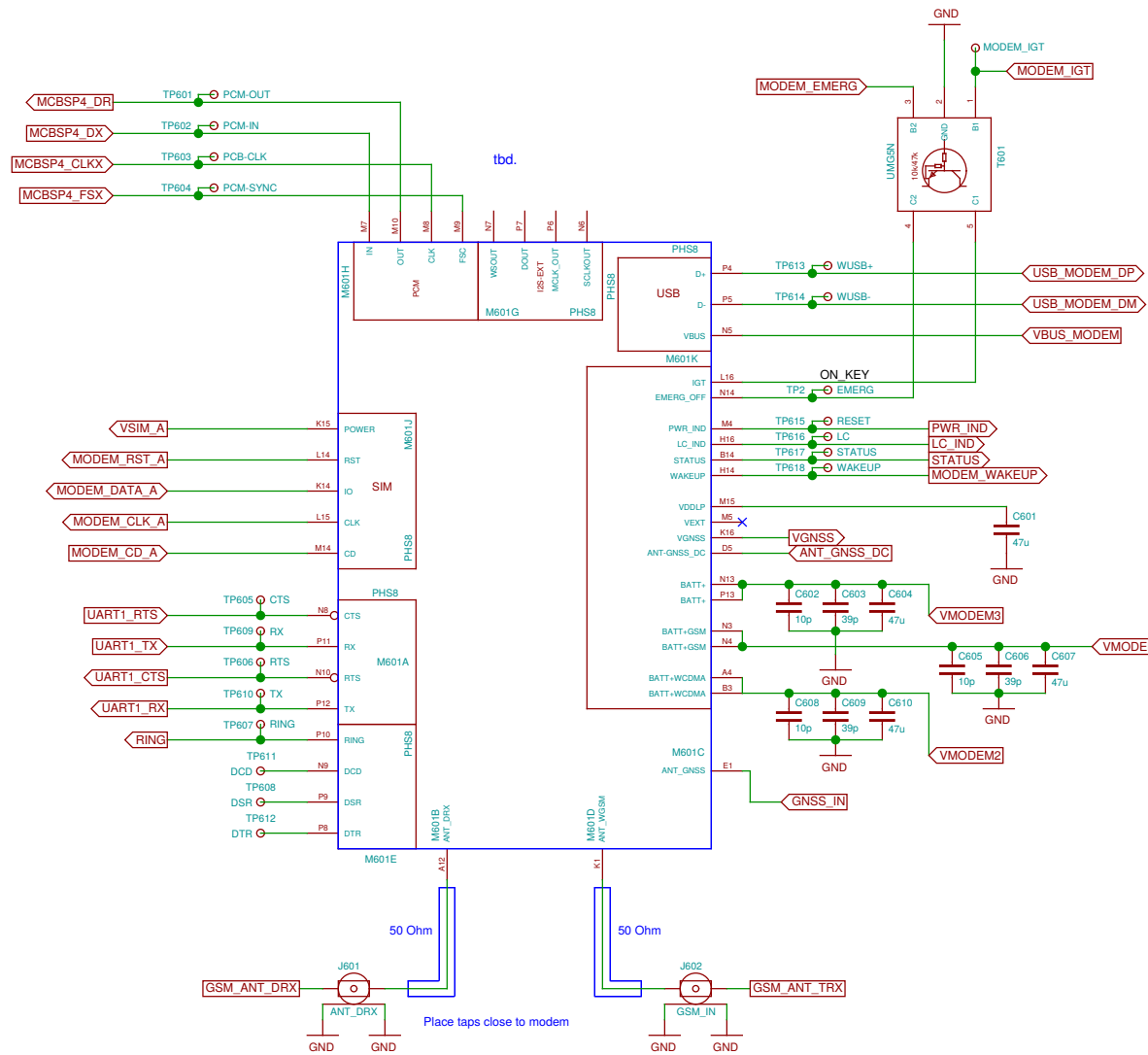

Note: MODEM\_CD\_\* (CCIN) is 1.8 V compatible.

Small logic gates are placed in close vicinity and share the bypass capacitor.

The FSA2866s operate at 3.3 V, for compatibility with Class B (2.7-3.3 V). The control inputs nOE and SEL are still 1.8 V compatible.

The delay timing is approximative. NXP provide the following formula:  $t_w = K * R * C = \text{approx. } 500 \text{ ms}$  for K estimated to be 0.5.

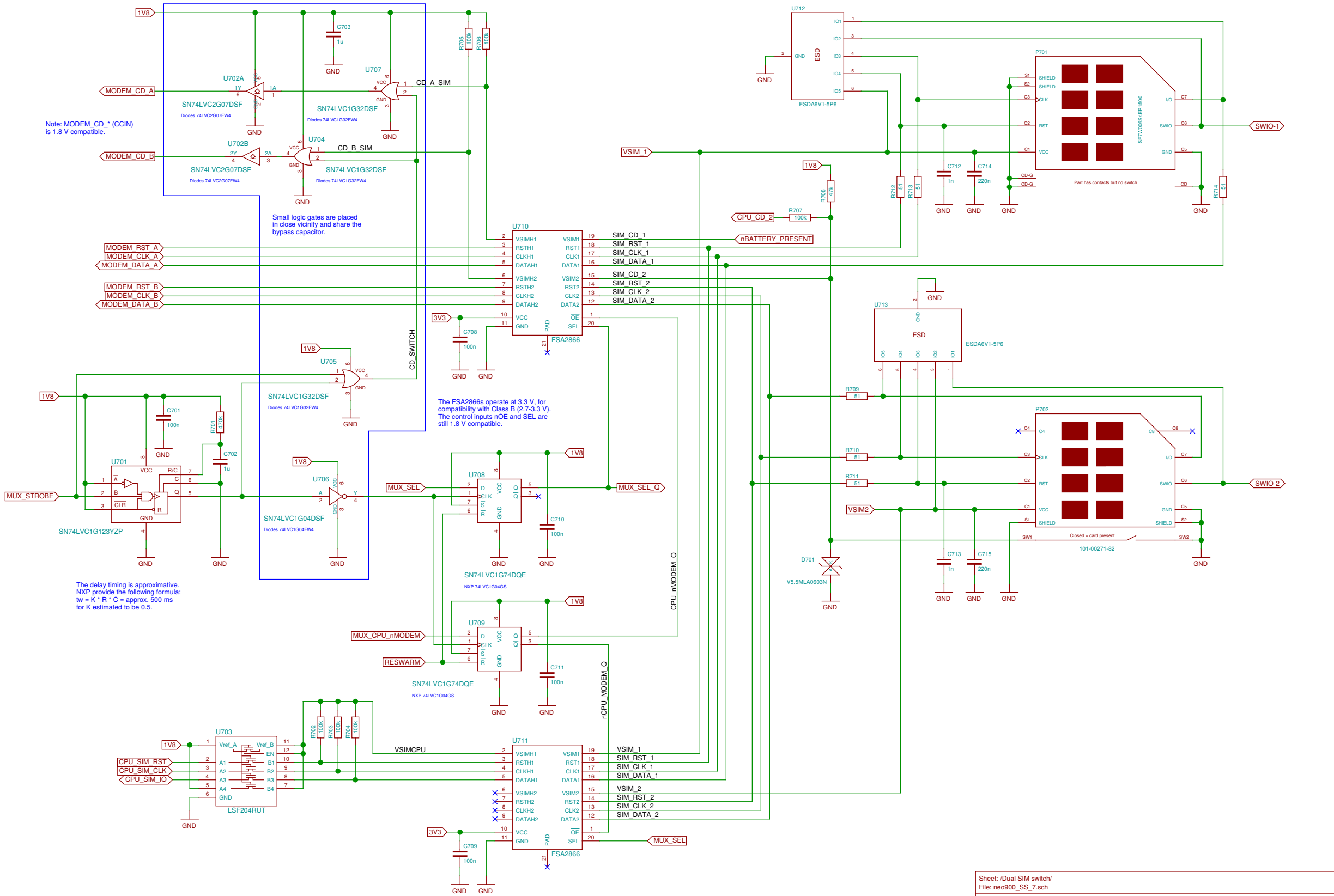

Sheet: /Dual SIM switch/ File: neo900_SS_7.sch		
Title: Dual SIM switch		
Size: A3	Date: 17 JUL 2016	Rev:
Plotted by eshow 14908eb+ 20160930-18:22Z		Id: 7/37

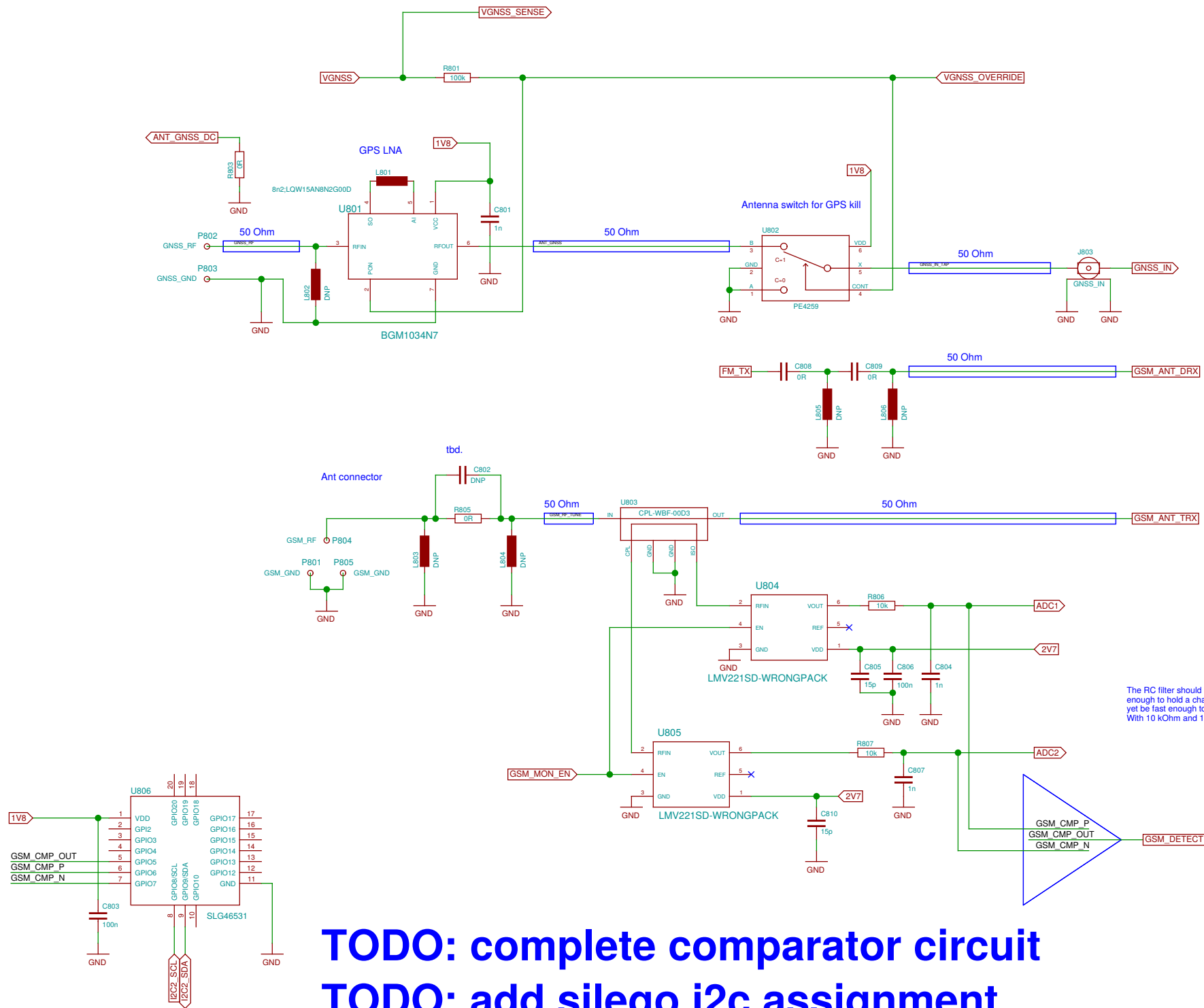

The RC filter should have C large enough enough to hold a charge in pulsed operation, yet be fast enough to detect short activity. With 10 kOhm and 1 nF, we get about 16 kHz.

**TODO: complete comparator circuit**  
**TODO: add silego i2c assignment**  
**TODO: iox**



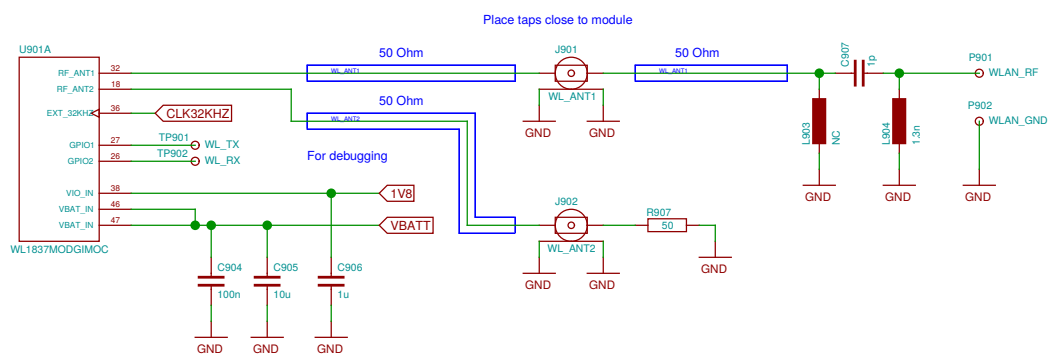

TODO: assign footprints

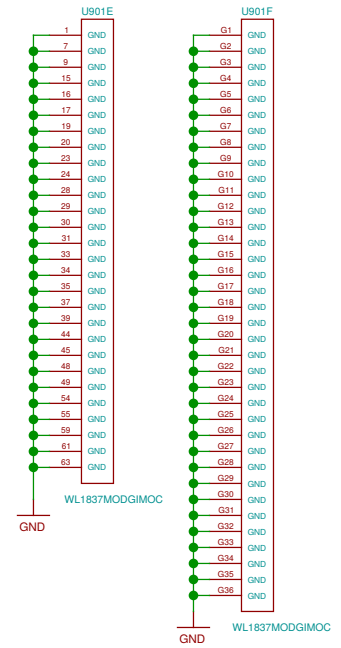
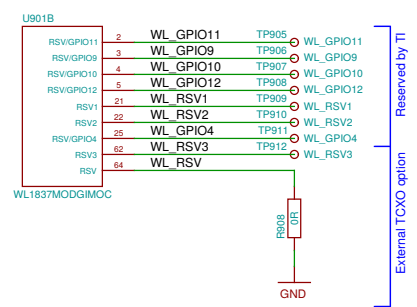
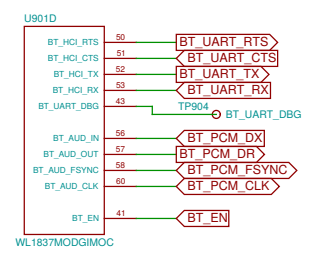
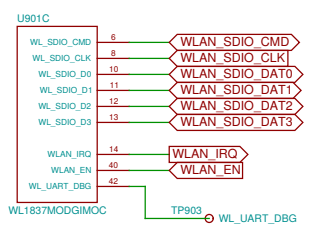

connect > 10cm loop or stub antenna

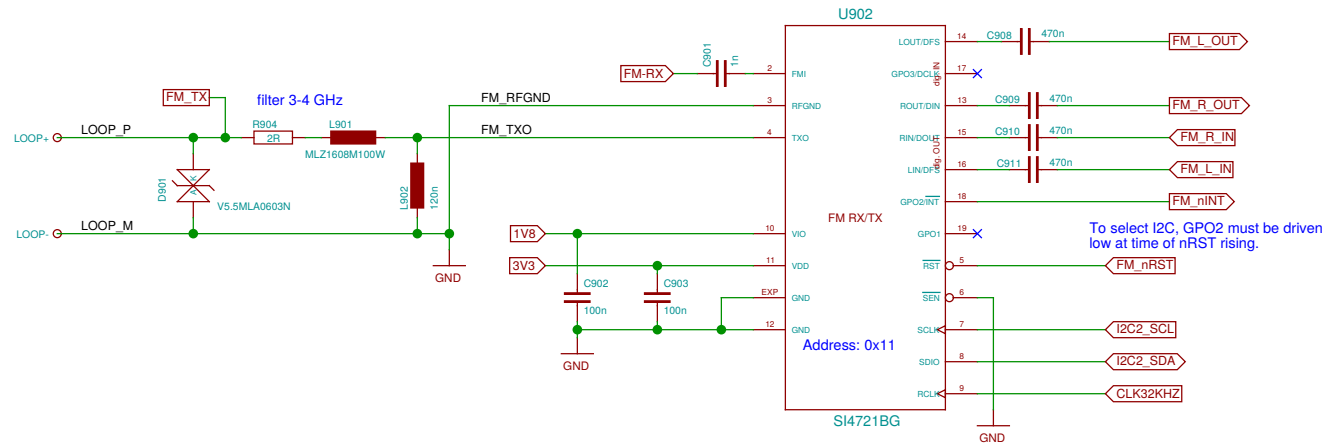

TODO: check caps

Si4705 is pin compatible (mostly) but RX-only

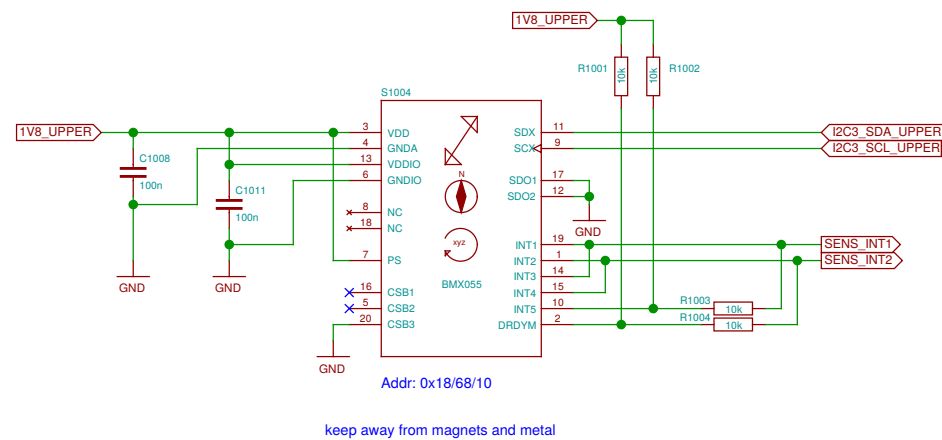
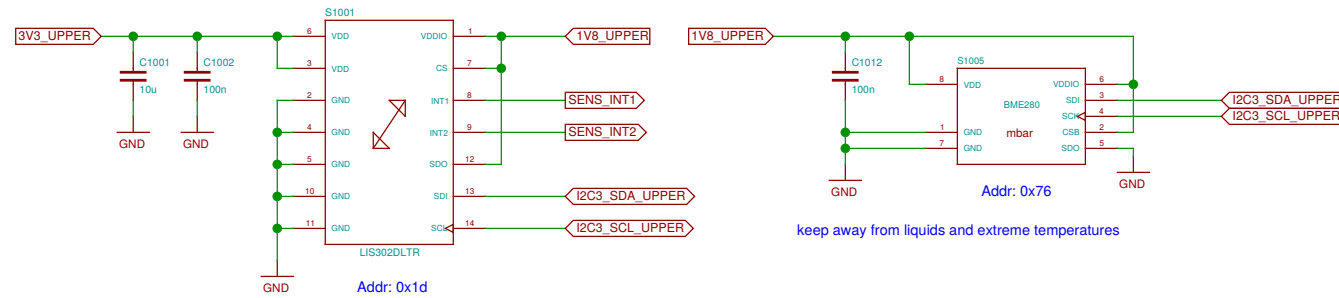

Sheet: /Sensors/		Date: 17 JUL 2016	
File: neo900_SS_10.sch		Rev:	
Title: Sensors			
Size: A3	Date: 17 JUL 2016	Rev:	
Plotted by eeshow 14908eb+ 20160930-18:22Z		Id: 10/37	

problem: this is a 0.5mm BGA making lower board expensive  
 but it appears to be not extremely critical (only 3 rows and inner ring is GND)  
 problem: analog mic is on upper board  
 alternative: place on upper board (to be evaluated)

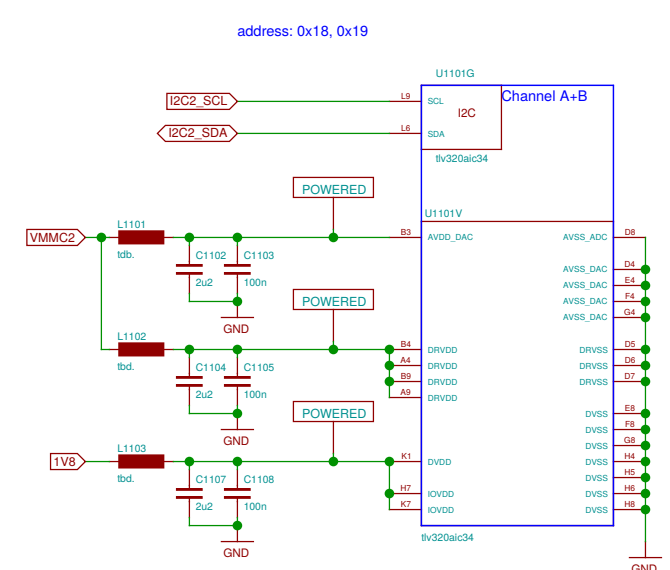
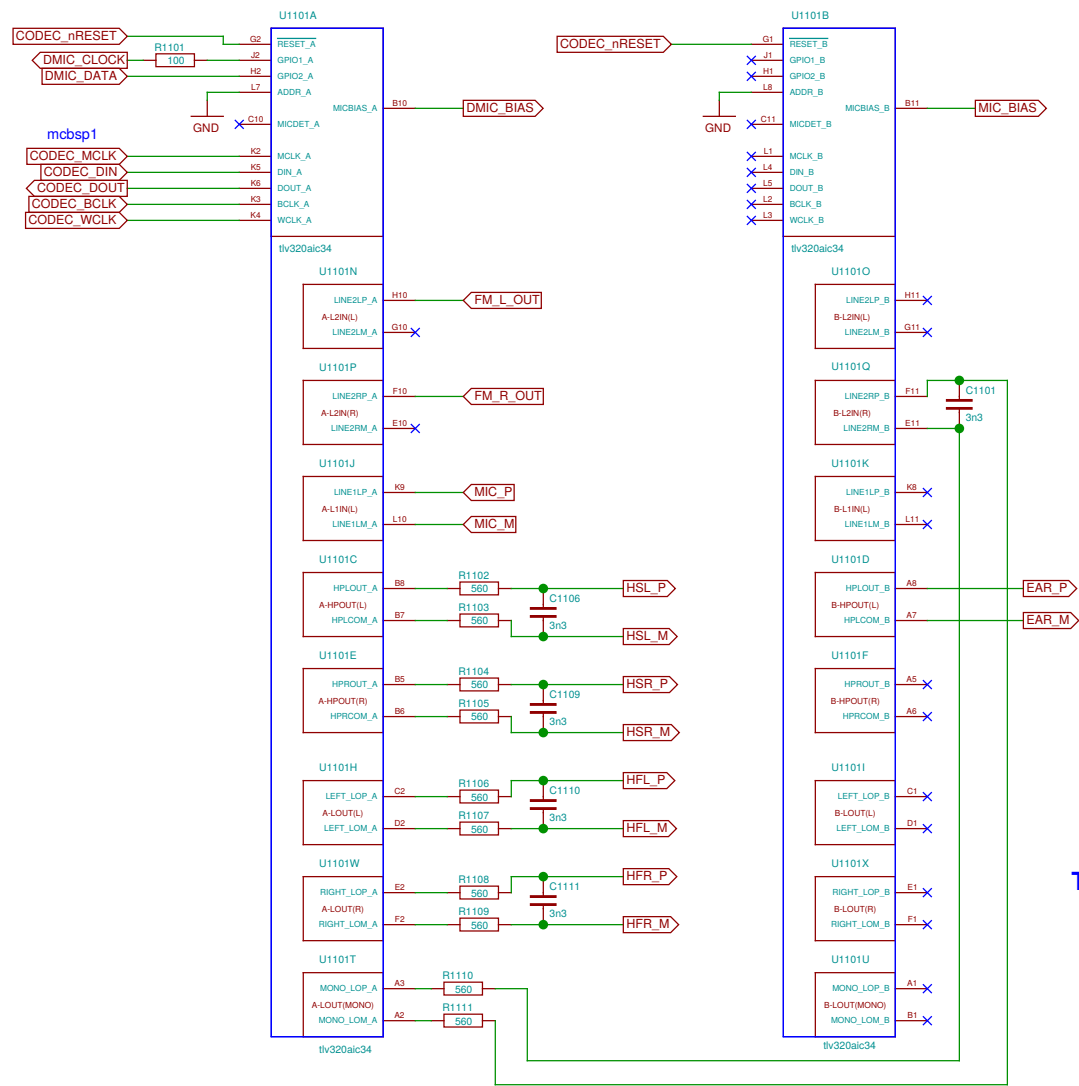

TODO: assign FM out

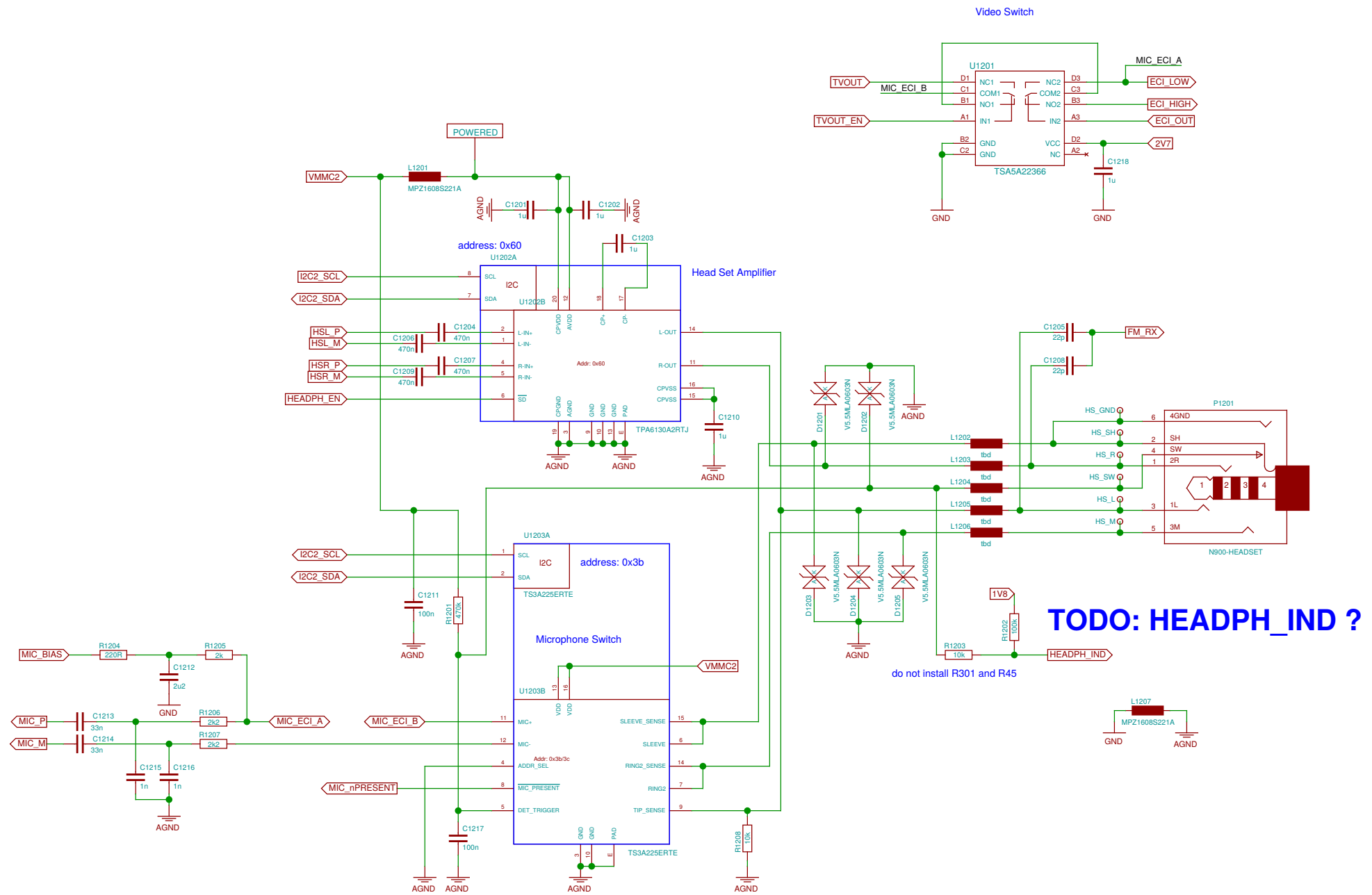

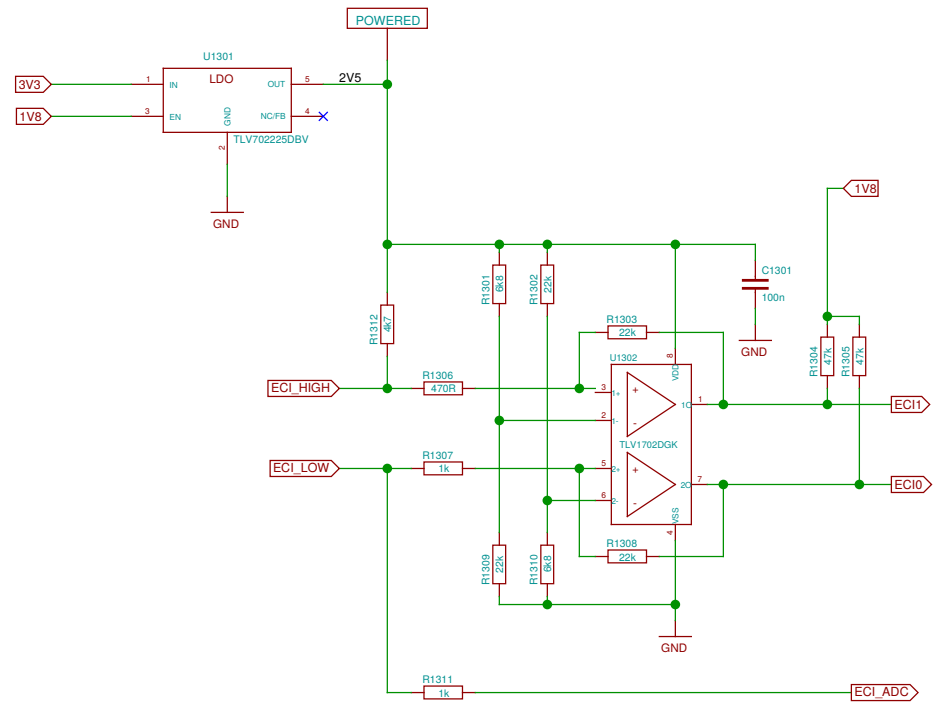

Sheet: /ECI/		File: neo900_SS_13.sch	
Title: ECI			
Size: A3	Date: 17 JUL 2016	Rev:	
Plotted by eeshow 14908eb+ 20160930-18:22Z		Id: 13/37	

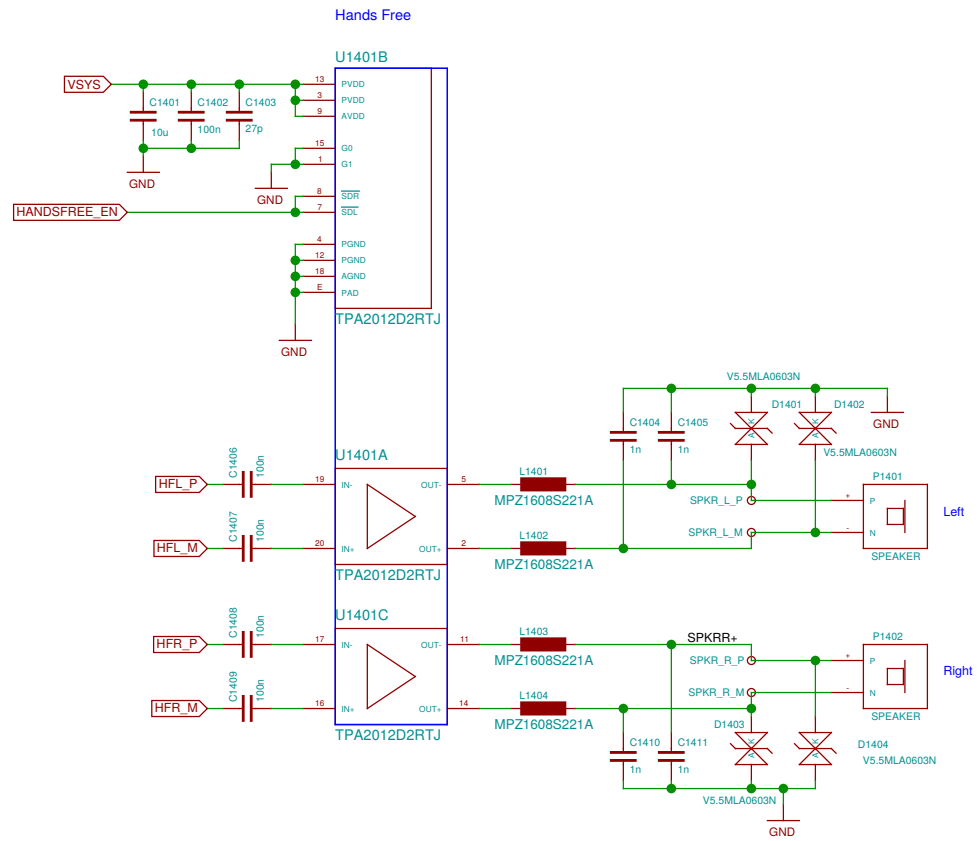

Sheet: /Audio Handsfree/		Date: 17 JUL 2016	
File: neo900_SS_14.sch		Rev:	
Title: Audio Handsfree			
Size: A3	Date: 17 JUL 2016	Rev:	
Plotted by eeshow 14908eb+ 20160930-18:22Z		Id: 14/37	

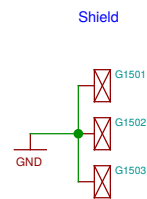
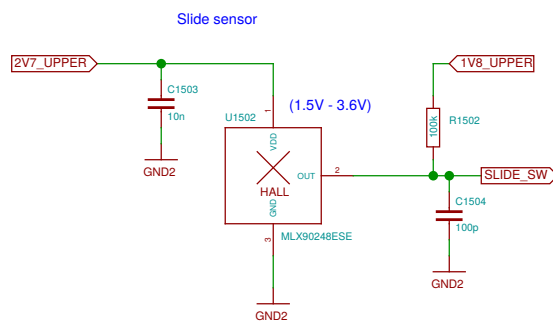
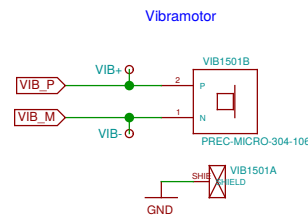
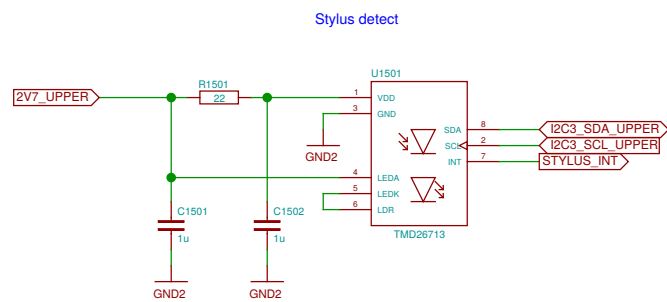

Sheet: /Misc/ File: neo900_SS_15.sch		
Title: Misc		
Size: A3	Date: 17 JUL 2016	Rev:
Plotted by eeshow 14908eb+ 20160930-18:22Z		Id: 15/37

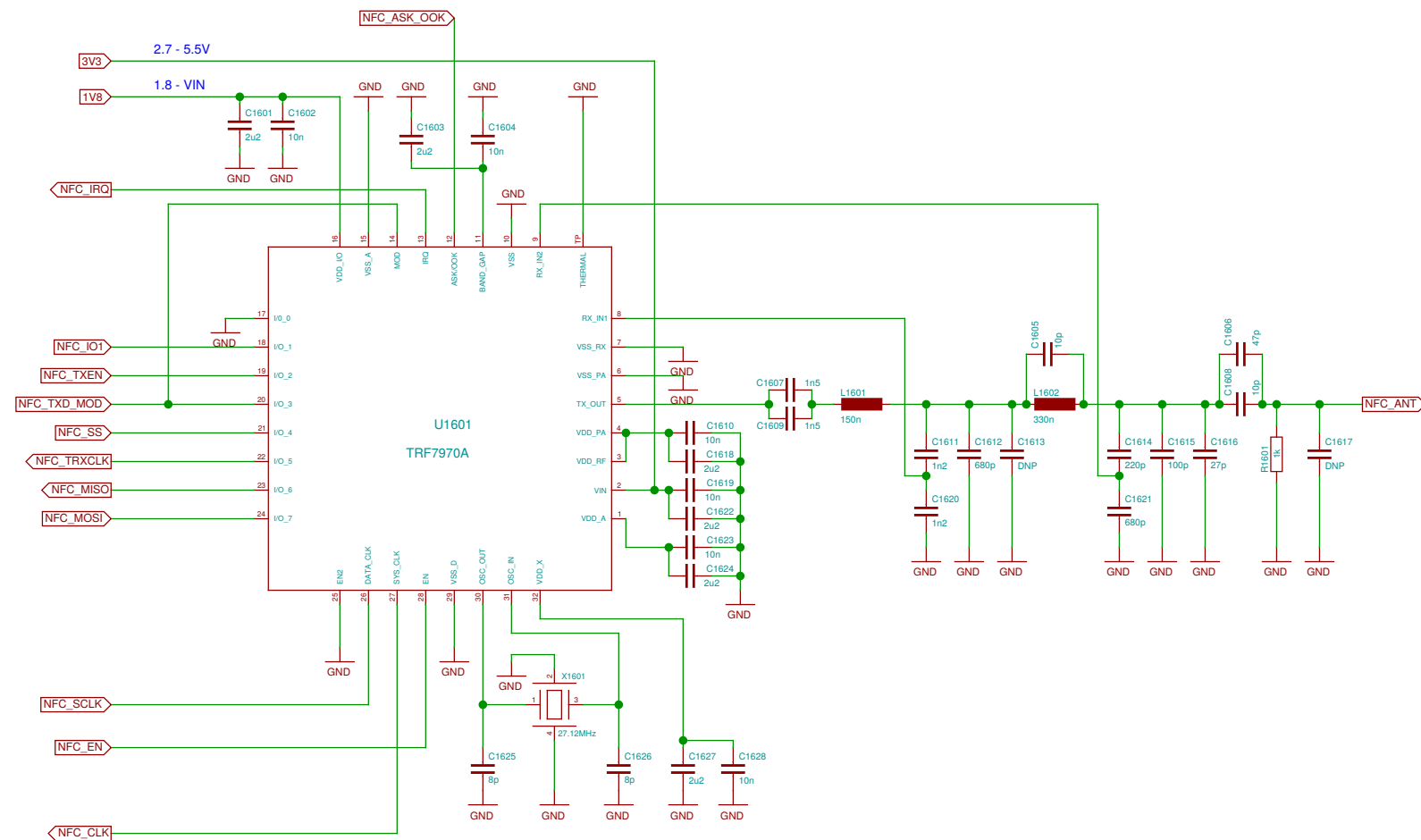

Some choices, 3.2 x 2.6 mm, 8-10 pF:  
 NDK NX3225GA-27.12M-STD-CRG-2  
 NDX NX3225SA-27.12M-STD-CSR-3  
 Tattien XXCCEINANF-27.120000



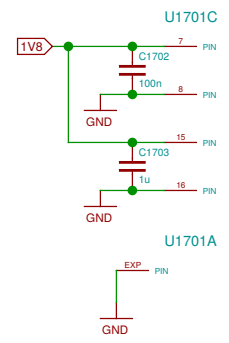
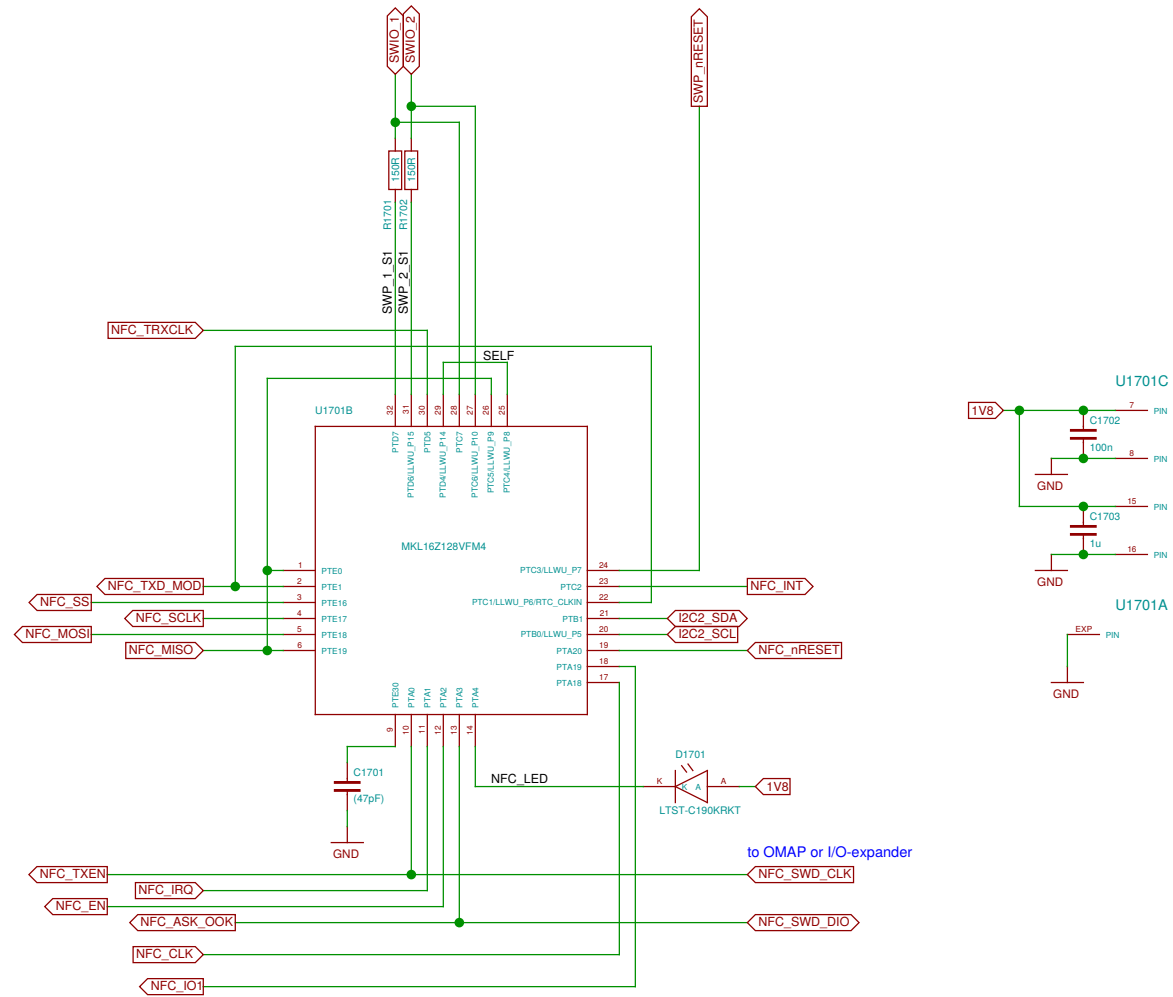

NOTE: this is mangling up Breakout and Lower board connectors  
 Signals may have to be fed through the breakout board connector increasing resistance

The LOWER-BOB interconnect is defined in the Hackerbus specification  
<http://neo900.org/stuff/papers/hb.pdf>

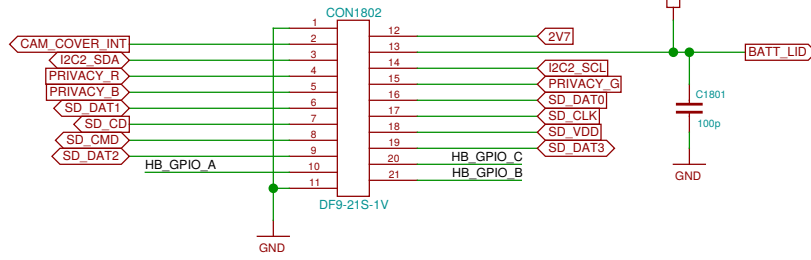
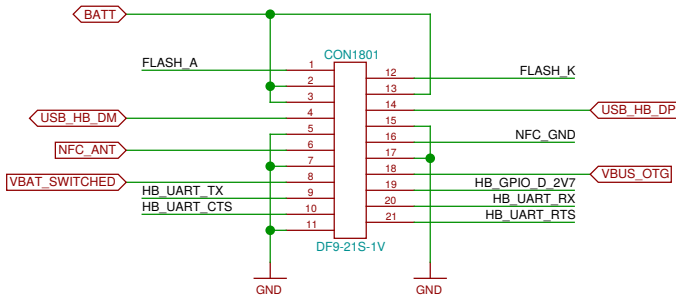

**TODO: define NFC-GND**

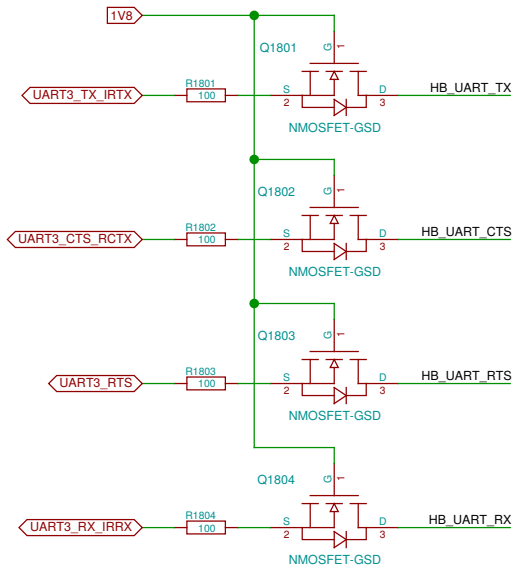
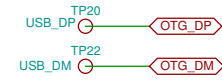

**TODO: use arrays**

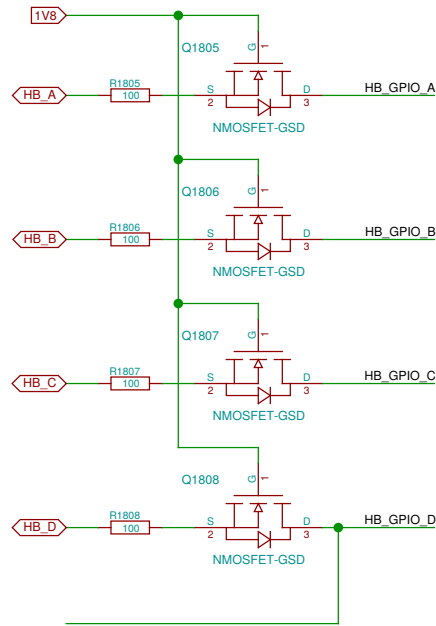

**TODO: 2V7+SW / LDO ?**

Missing 10 level shifter chip (or do we really have the space for 10x discrete T+R+D ca. 3x3mm each?)  
 Missing 6x 2R for alternate function select (do we have the space for ca. 2.5 x 5mm?)

**TODO: HB USB PHY goes here**

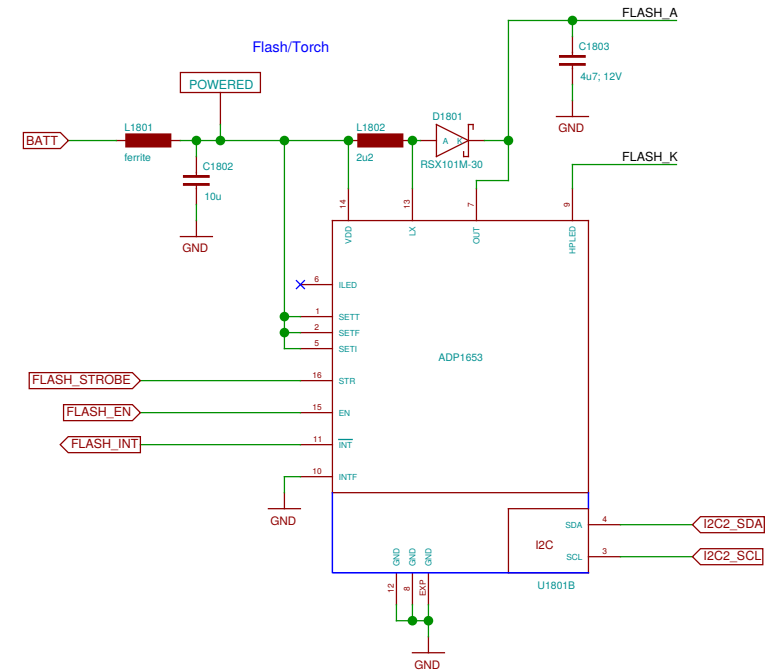

Sheet: /Hackerbus/ File: neo900_SS_18.sch		Title: Hackerbus	
Size: A3	Date: 17 JUL 2016	Rev:	
Plotted by eeshow 14908eb+ 20160930-18:22Z		Id: 18/37	

# TODO: update D1901 footprint

NOTE: 1V8 may be quite noisy

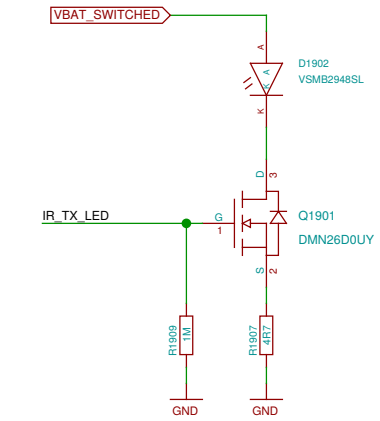
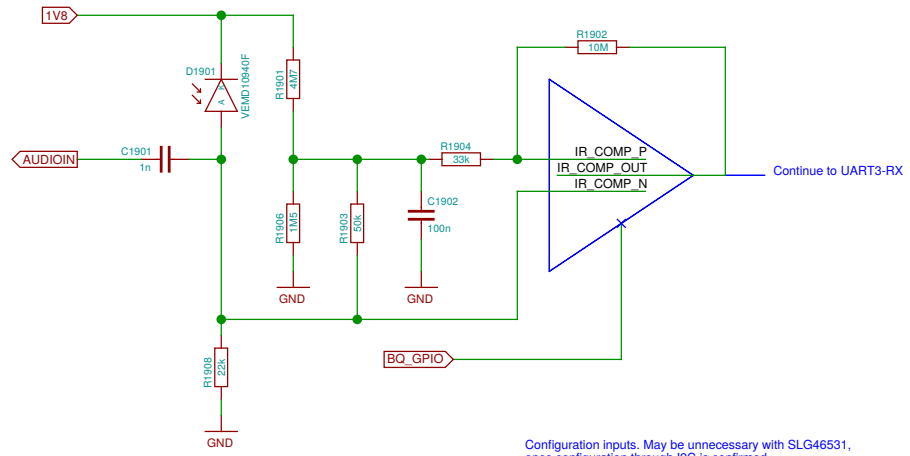

Configuration inputs. May be unnecessary with SLG46531, once configuration through I2C is confirmed.

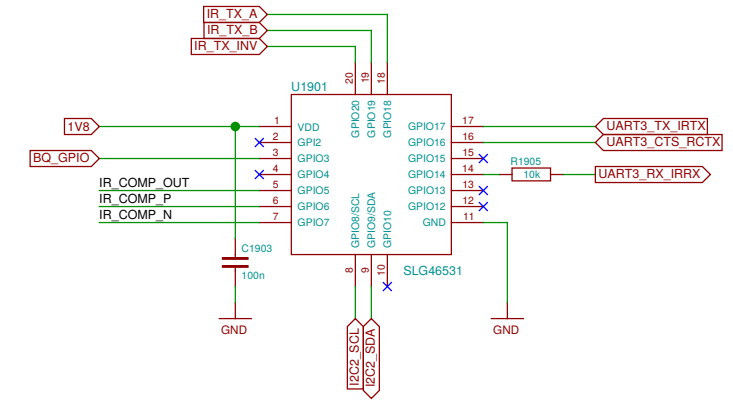

This is just the collection of signals we have.  
Proper assignment still pending.

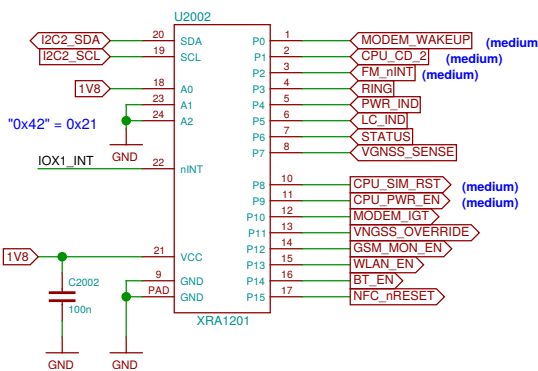
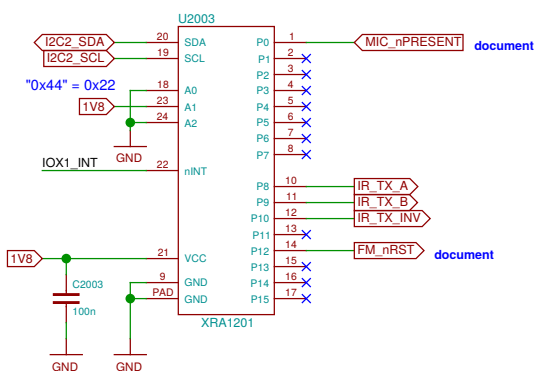
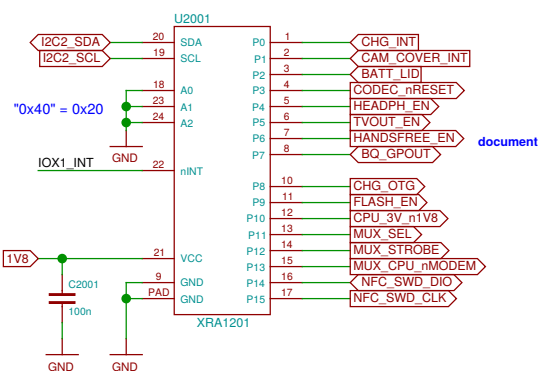
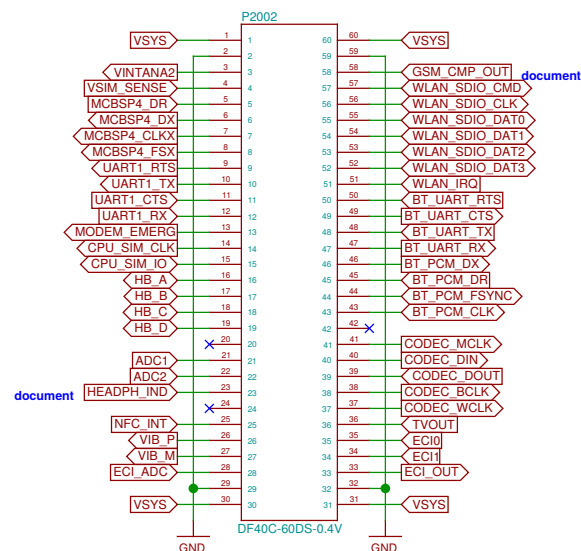
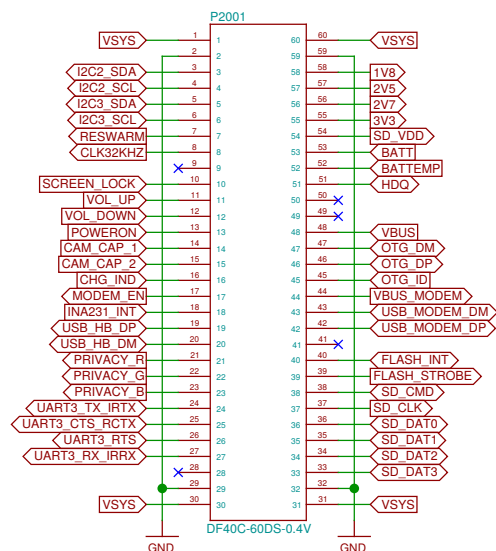

# TODO: add ESD protection (here)

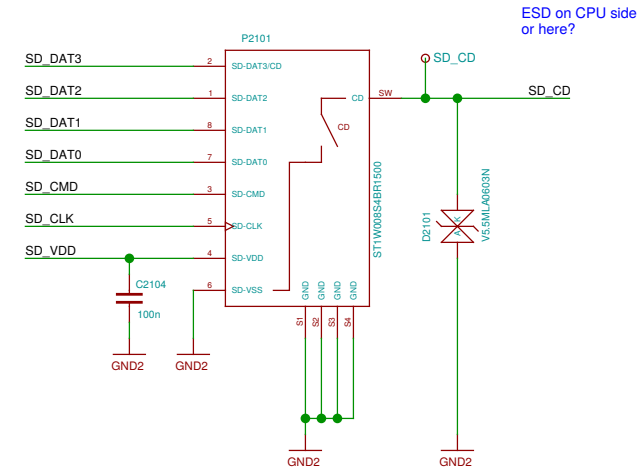
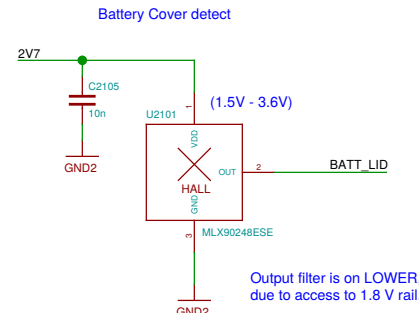
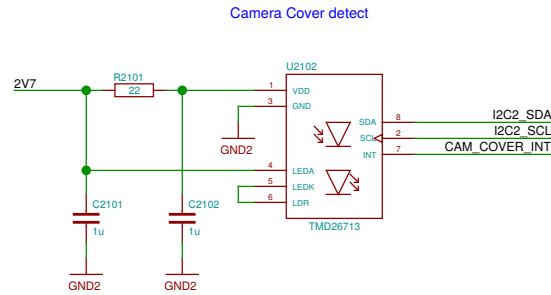

The LOWER\_BOB interconnect is defined in the Hackabus specification  
<http://neo900.org/stuff/papers/hb.pdf>

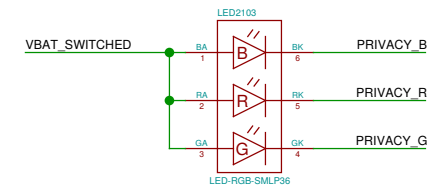
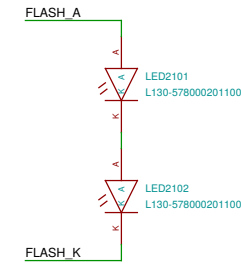
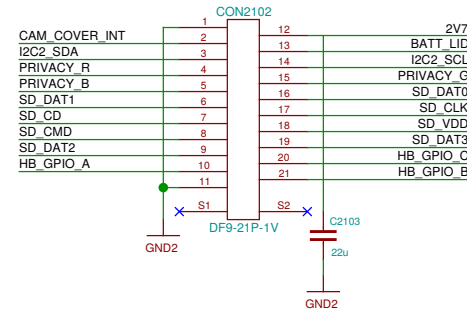
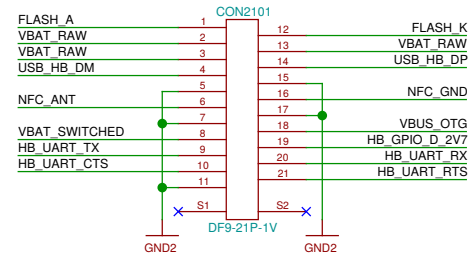

## Hackabus

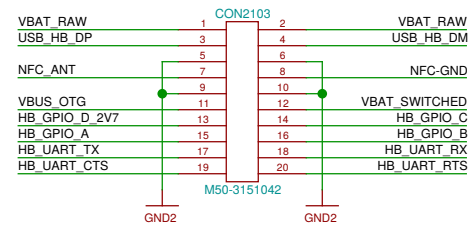

# TODO: track B2B to UPPER

to be adjusted to lower board connector

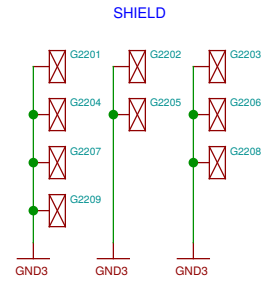
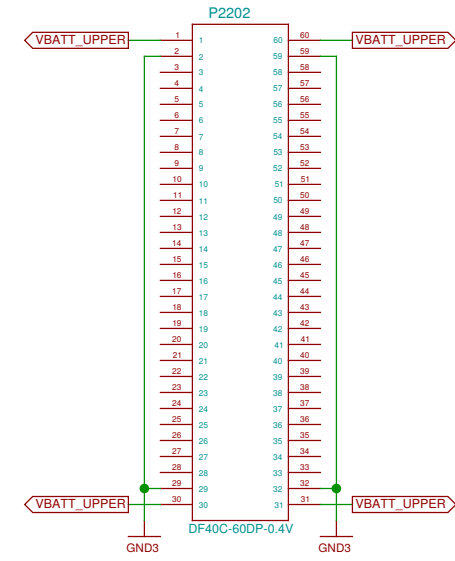
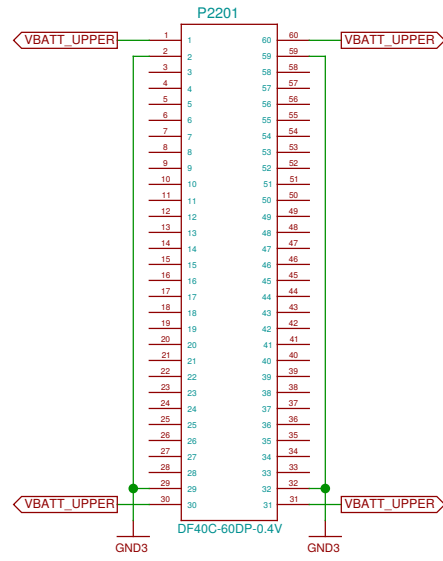

needs final tuning (which button on which position)  
 VOL+ and VOL- could drive FETs sitting in the matrix

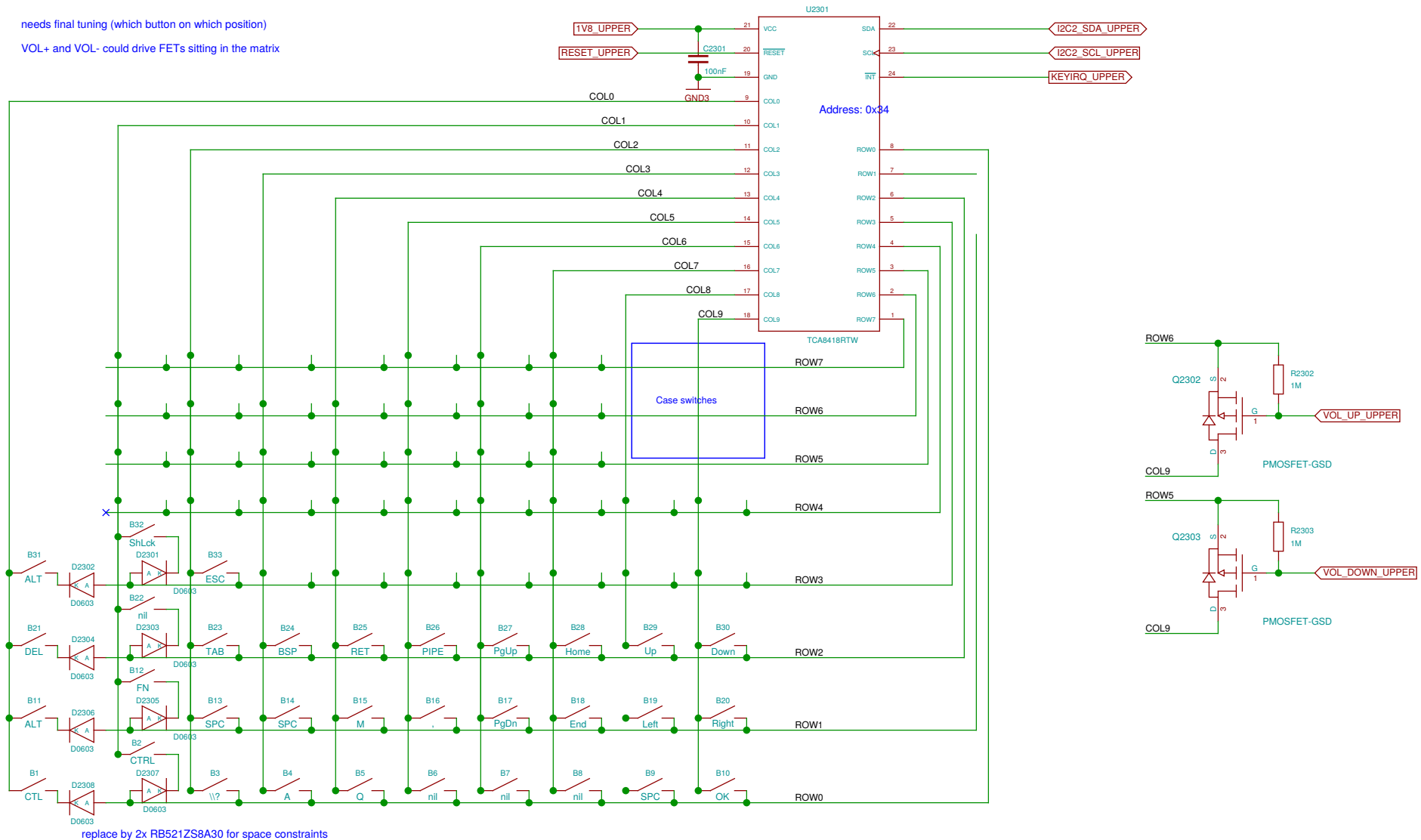

replace by 2x RB521ZS8A30 for space constraints

**TODO: key names are nonsense**

**TODO: rearrange matrix to avoid diodes ?**

Resistive Touch (display connector)

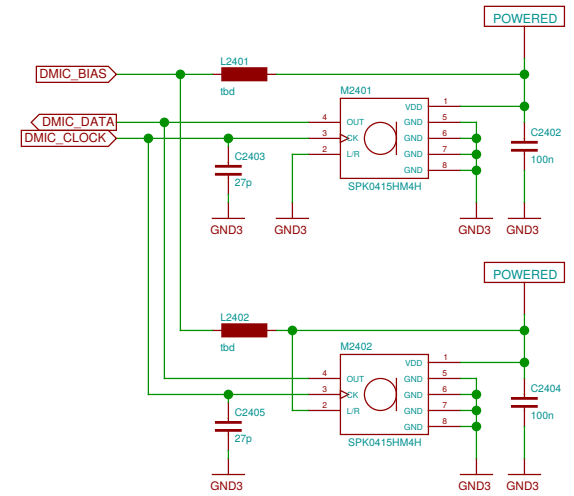
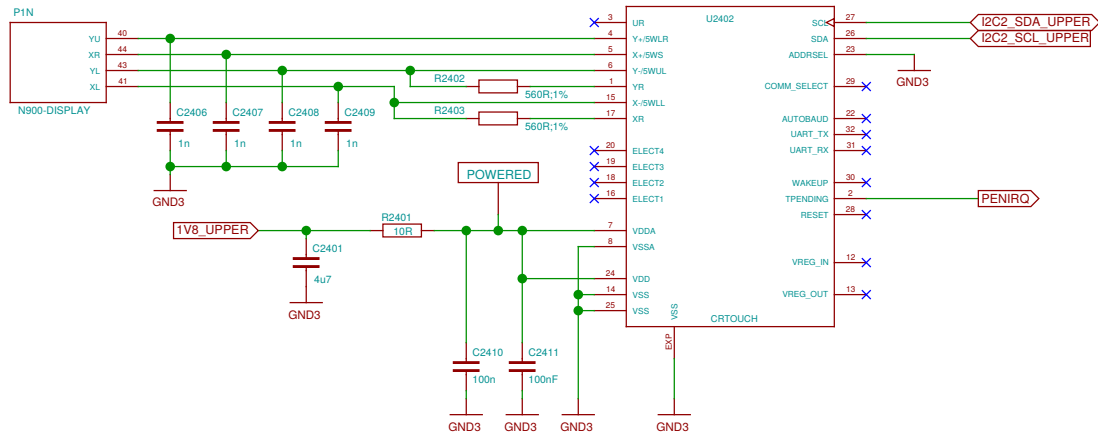





**OMAP is not part of v2**

Sheet: /CPU + PoP RAM/NAND/ File: neo900_SS_26.sch		
Title: CPU + PoP RAM/NAND		
Size: A3	Date: 17 JUL 2016	Rev:
Plotted by eeshow 14908eb+ 20160930-18:22Z		Id: 26/37

**eMMC is not part of v2**

Sheet: /eMMC/ File: neo900_SS_27.sch		
Title: eMMC		
Size: A3	Date: 17 JUL 2016	Rev:
Plotted by eeshow 14908eb+ 20160930-18:22Z		Id: 27/37

**Companion chip (TPS65950) is not part of v2**

Sheet: /PMU+Codec/ File: neo900_SS_28.sch		
Title: PMU+Codec		
Size: A3	Date: 17 JUL 2016	Rev:
Plotted by eeshow 14908eb+ 20160930-18:22Z		Id: 28/37

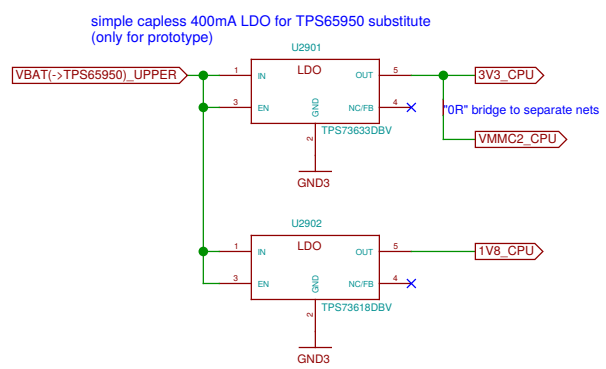

Sheet: /BB-XM Dummy (TWL4030)/		
File: neo900_SS_29.sch		
Title: BB-XM Dummy (TWL4030)		
Size: A3	Date: 17 JUL 2016	Rev:
Plotted by eeshow 14908eb+ 20160930-18:22Z		Id: 29/37

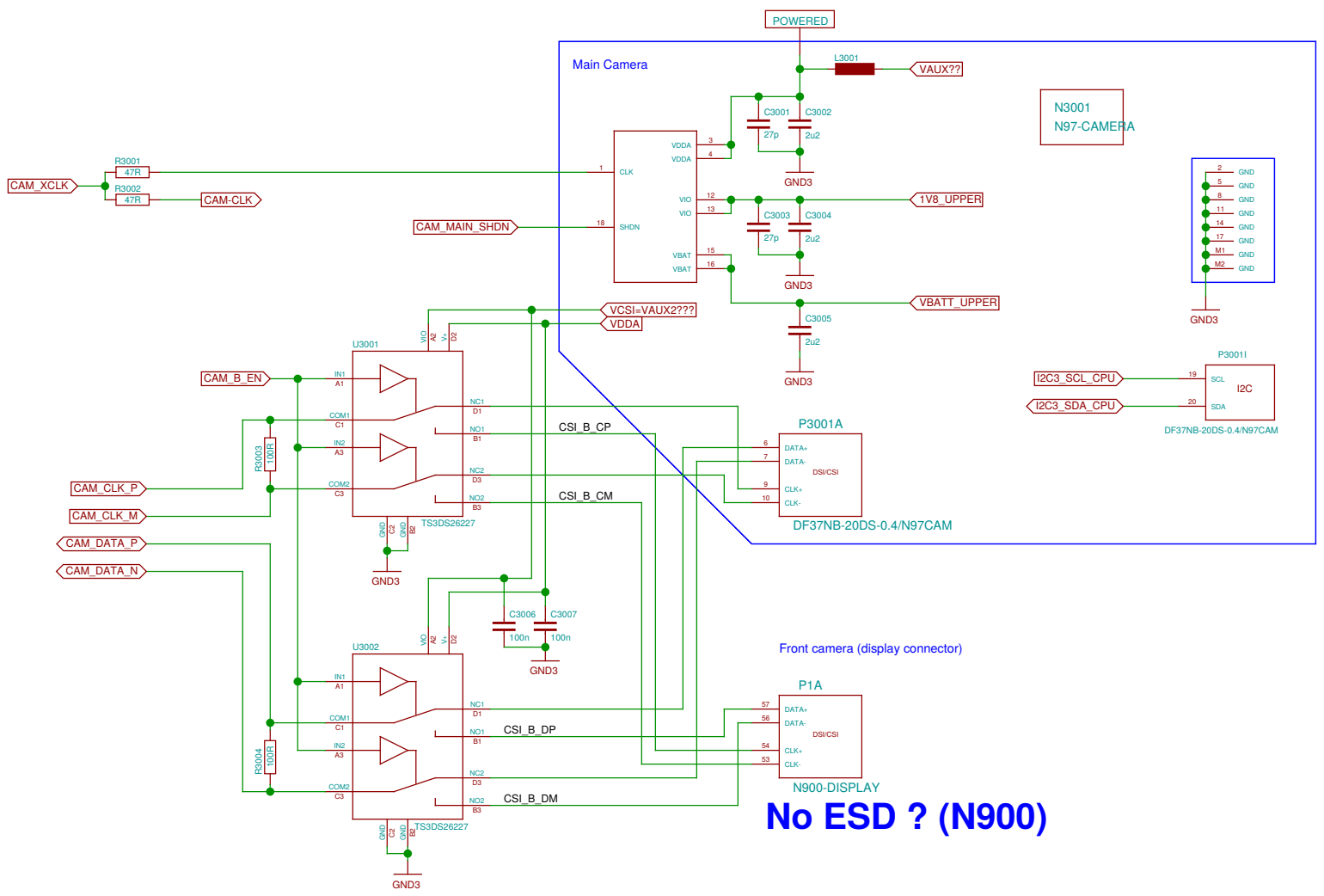

**No ESD ? (N900)**

Sheet: /Camera/ File: neo900_SS_30.sch	
Title: Camera	
Size: A3	Date: 17 JUL 2016
Plotted by eeshow 14908eb+ 20160930-18:22Z	
Rev:	Id: 30/37



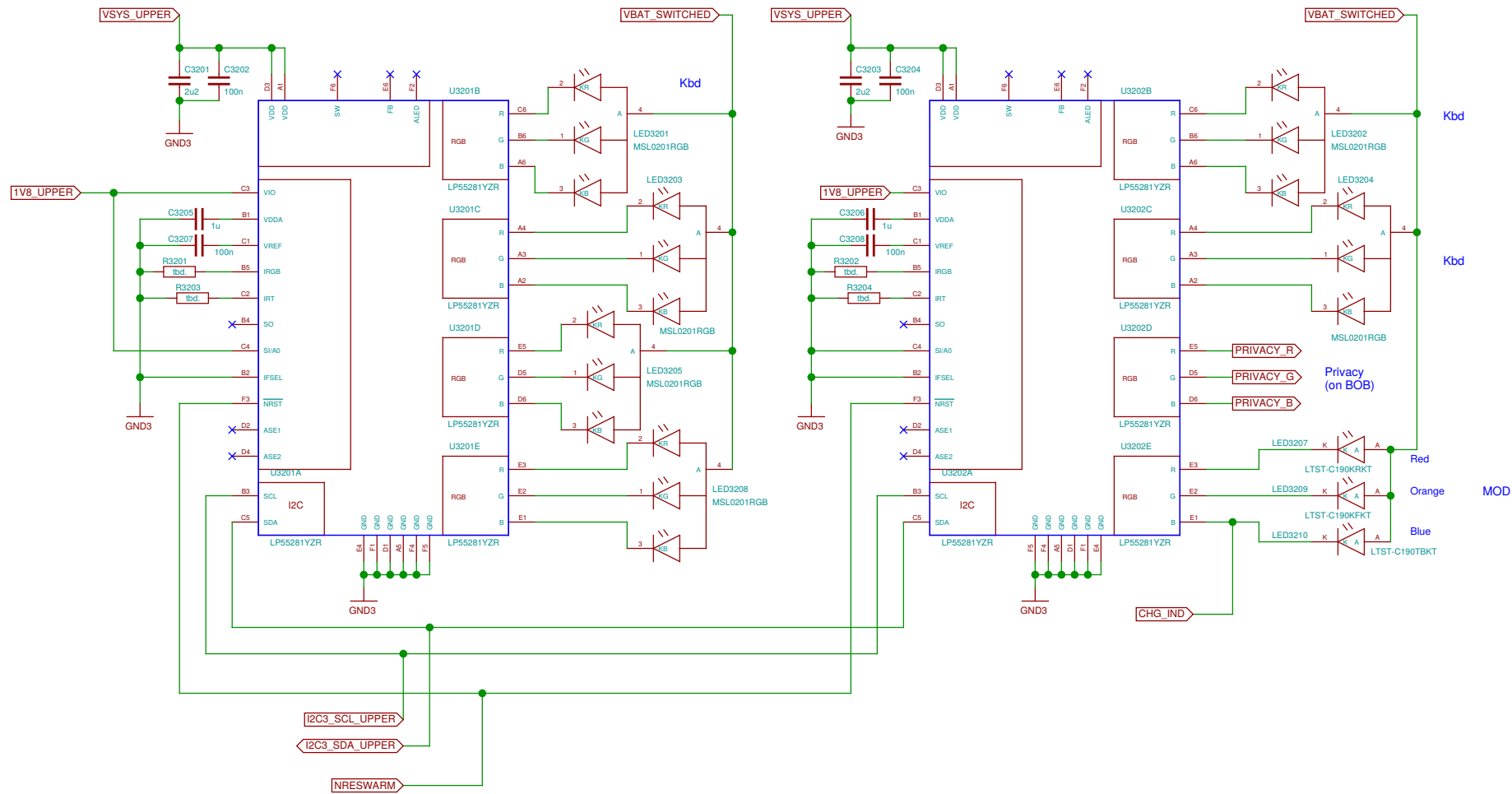



These connectors allow to "emulate" the DM3730 by connecting a BB-XM

INCOMPLETE  
prototype only

Connect to OMAP3 McSPI1, I2C2, MMC2 / some GPIOs

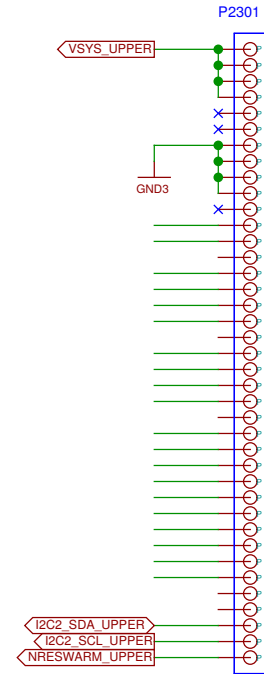

connect to respective CPU-pads

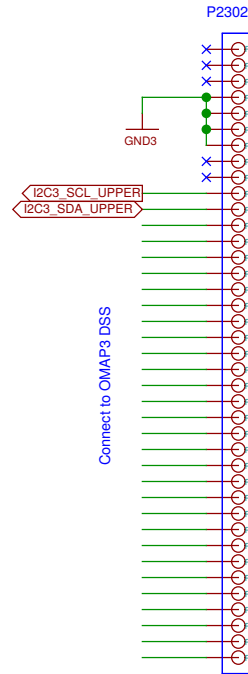

Connect to OMAP3 DSS

DSS / GPIOs, I2C3

Connect to OMAP3 Camera

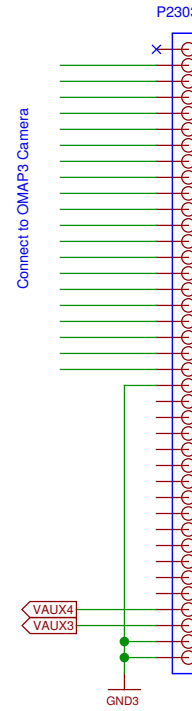

connect to BB  
by some Micro-USB cable

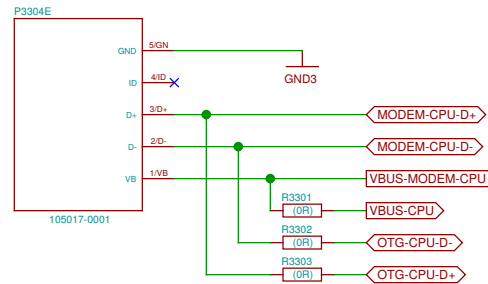

**TODO: VBUS-MODEM ?**

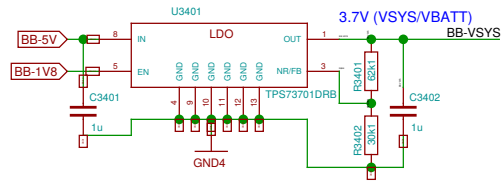

Ersetzen durch 2A buck converter

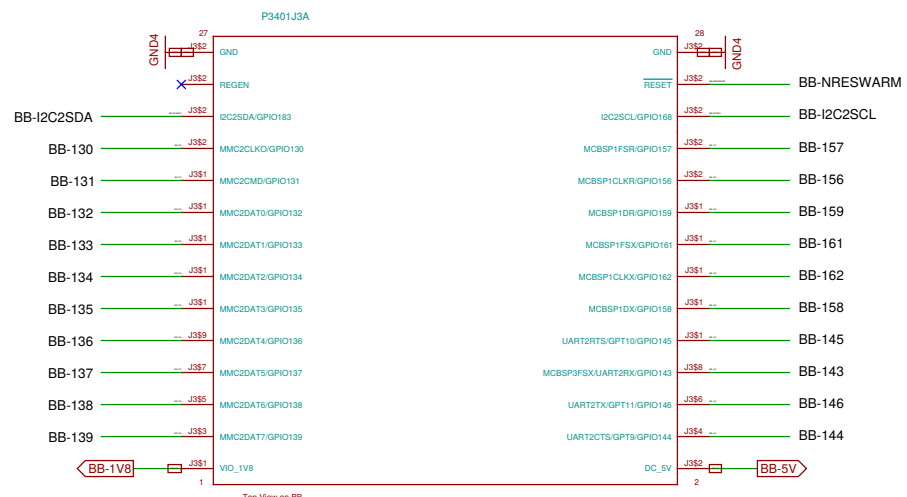
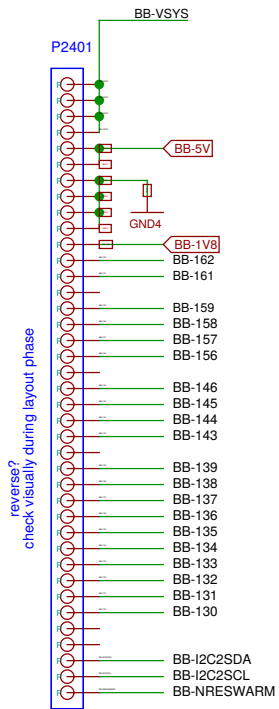

BB-xM Main Expansion Header (7.24)

**TODO: needs decision on where to take this**

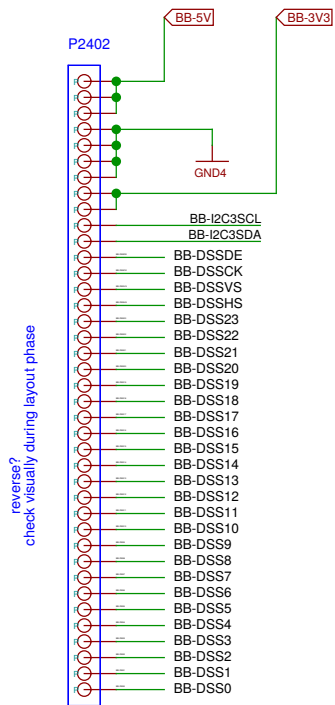

reverse?  
check visually during layout phase

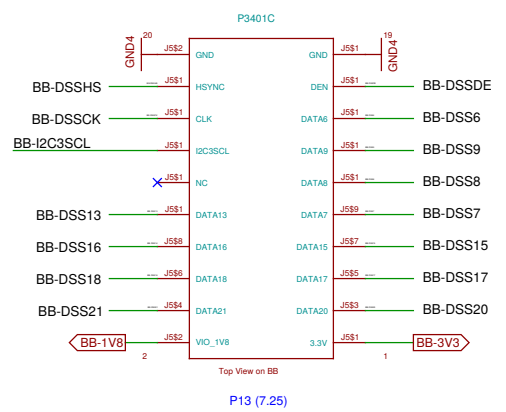
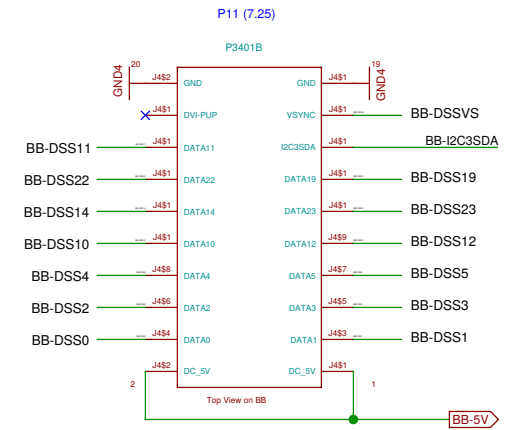

**TODO: needs decision on where to take this**

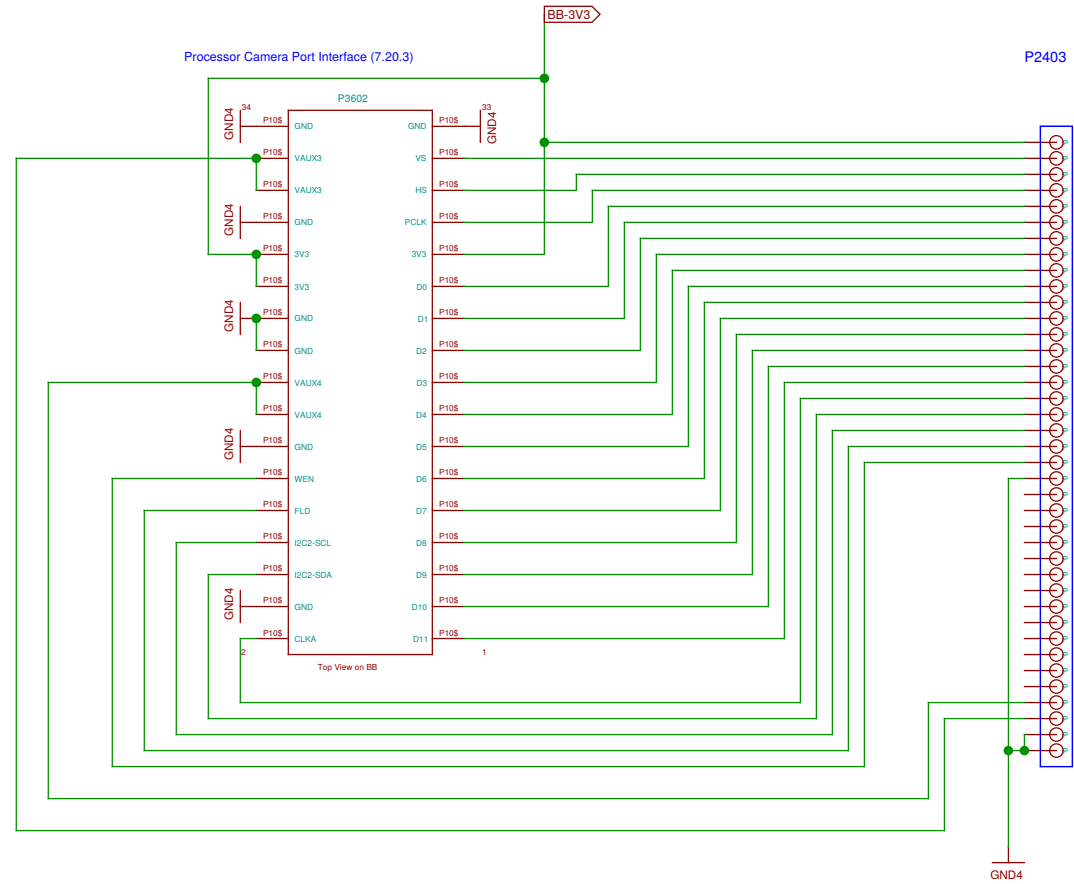

reverse?  
check visually during layout phase

Sheet: /BB-XM Adapter (CAM)/		
File: neo900_SS_36.sch		
Title: BB-XM Adapter (CAM)		
Size: A3	Date: 17 JUL 2016	Rev:
Plotted by eeshow 14908eb+ 20160930-18:22Z		Id: 36/37

Molex Jumper cables to connect BB-XM-Adapter to Uppwer board

N3701 15015-0439	N3702 15015-0439	N3703 15015-0439
CPU	DISP	CAM

N3704 N900 case assembly
-----------------------------

N3705 N97-CAMERA-HOLE
--------------------------

N3706 headset jack
-----------------------

N3707 STENCIL-TOP
----------------------

N3708 STENCIL-BOTTOM
-------------------------

Sheet: /No-Solder Components/ File: neo900_SS_37.sch		
Title: No-Solder Components		
Size: A3	Date: 17 JUL 2016	Rev:
Plotted by eeshow 14908eb+ 20160930-18:22Z		Id: 37/37