

1	2	3	4	5	6	7	8	9	10	11
Click Here										
V										
This sheet: index										
Sheet: OTG										
File: neo900_SS_2.sch										
OTG & Switches										
Sheet: Charger/OTG-Booster										
File: neo900_SS_3.sch										
Charger/OTG-Booster										
Sheet: Modem Power										
File: neo900_SS_4.sch										
Modem Power										
Sheet: Fuel Gauge										
File: neo900_SS_5.sch										
Fuel Gauge										
Sheet: 3G/4G Modem + SIM										
File: neo900_SS_6.sch										
3G/4G Modem + SIM										
Sheet: Dual SIM switch										
File: neo900_SS_7.sch										
Dual SIM switch										
Sheet: Antenna connections										
File: neo900_SS_8.sch										
Antenna connections										
Sheet: WLAN, Bluetooth, FM										
File: neo900_SS_9.sch										
WLAN, Bluetooth, FM										
Sheet: Sensors										
File: neo900_SS_10.sch										
Sensors										
Sheet: Audio Codec										
File: neo900_SS_11.sch										
Audio Codec										
Sheet: Audio Headset + Mic										
File: neo900_SS_12.sch										
Audio Headset + Mic										
Sheet: ECI										
File: neo900_SS_13.sch										
ECI										
Sheet: Audio Handsfree										
File: neo900_SS_14.sch										
Audio Handsfree										
Sheet: Misc										
File: neo900_SS_15.sch										
Misc										
Sheet: RFID/NFC Reader										
File: neo900_SS_16.sch										
RFID/NFC Reader										
Sheet: RFID/NFC Controller										
File: neo900_SS_17.sch										
RFID/NFC Controller										
Sheet: Hackerbus										
File: neo900_SS_18.sch										
Hackerbus										
Sheet: Infrared										
File: neo900_SS_19.sch										
Infrared										
Sheet: B2B LOWER-UPPER										
File: neo900_SS_20.sch										
B2B LOWER-UPPER										
Sheet: uSD Breakout Board										
File: neo900_SS_21.sch										
uSD Breakout Board										
Sheet: empty										
File: neo900_SS_22.sch										
empty										
Sheet: Keypad										
File: neo900_SS_23.sch										
Keypad										
Sheet: Display-Peripherals										
File: neo900_SS_24.sch										
Display-Peripherals										
Sheet: Display-Panel&Power										
File: neo900_SS_25.sch										
Display-Panel&Power										
Sheet: CPU + PoP RAM/NAND										
File: neo900_SS_26.sch										
CPU + PoP RAM/NAND										
Sheet: eMMC										
File: neo900_SS_27.sch										
eMMC										
Sheet: PMU+Codec										
File: neo900_SS_28.sch										
PMU+Codec										
Sheet: BB-XM Dummy (TWL4030)										
File: neo900_SS_29.sch										
BB-XM Dummy (TWL4030)										
Sheet: Camera										
File: neo900_SS_30.sch										
Camera										
Sheet: Fancy LEDs										
File: neo900_SS_31.sch										
Fancy LEDs										
Sheet: Basic LEDs										
File: neo900_SS_32.sch										
Basic LEDs										
Sheet: Connector to BB-XM										
File: neo900_SS_33.sch										
Connector to BB-XM										
Sheet: BB-XM Adapter (CPU)										
File: neo900_SS_34.sch										
BB-XM Adapter (CPU)										
Sheet: BB-XM Adapter (DISP)										
File: neo900_SS_35.sch										
BB-XM Adapter (DISP)										
Sheet: BB-XM Adapter (CAM)										
File: neo900_SS_36.sch										
BB-XM Adapter (CAM)										
Sheet: No-Solder Components										
File: neo900_SS_37.sch										
No-Solder Components										
Note regarding I2C addresses: Addresses in the schematics are provided for convenience. The authoritative source is https://neo900.org/git/misc/tree/i2c										
Sheet: /										
File: neo900.sch										
Title: Neo900										
Size: A3										
Date: 2016-10-28 21:16:24										
Rev:										
Plotted by eeshow 96ef3e0+ 20161030-17:20Z										
Id: 1/37										
(c) CC-BY-SA 2014-2016 Neo900 & GDC										
1	2	3	4	5	6	7	8	9	10	11

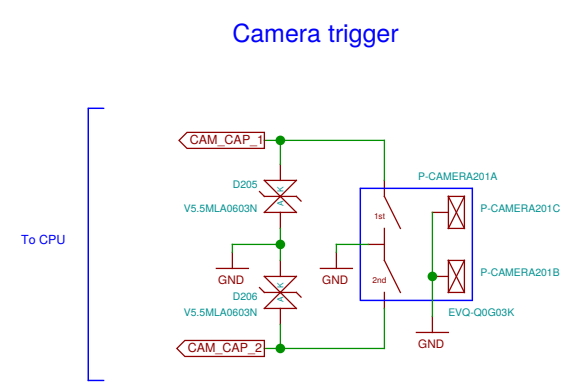

USB OTG connector

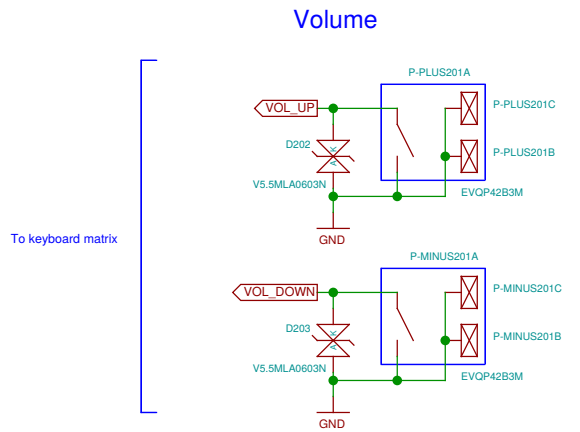
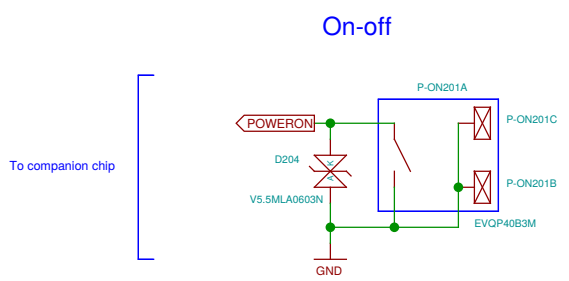
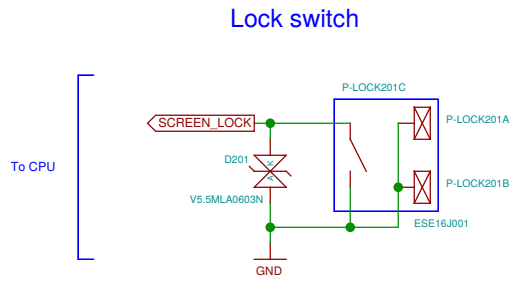
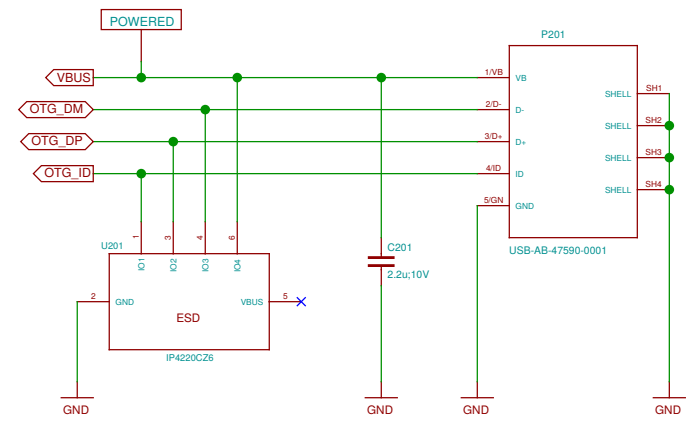

Sheet: /OTG/ File: neo900_SS_2.sch		
Title: OTG		
Size: A3	Date: 2016-10-28 21:16:24	Rev:
Plotted by eeshow 96ef3e0+ 20161030-17:20Z		Id: 2/37

Battery charger with USB OTG

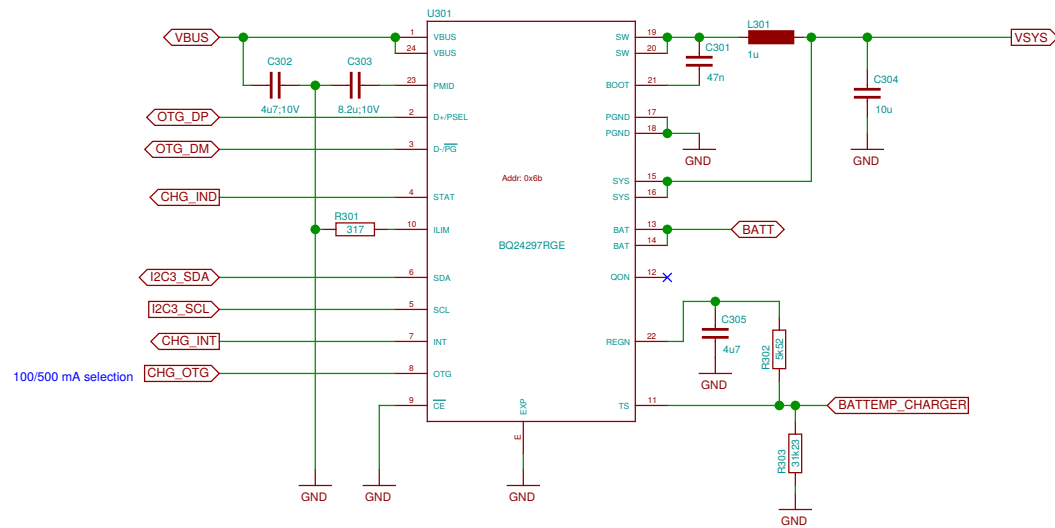

Power distribution and sequencing

Most high-current consumers are on VBAT_SWITCHED.
1V8 signals that the regulators on UPPER are operational.

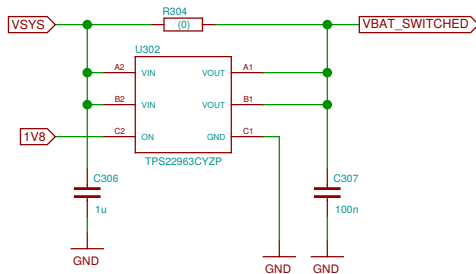

KiCad bureaucracy

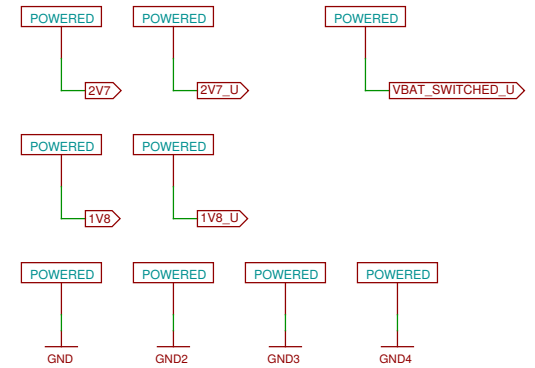

Sheet: /Charger/OTG-Booster/		
File: neo900_SS_3.sch		
Title: Charger/OTG-Booster		
Size: A3	Date: 2016-10-28 21:16:24	Rev:
Plotted by eeshow 96ef3e0+ 20161030-17:20Z		Id: 3/37

Modem current monitor

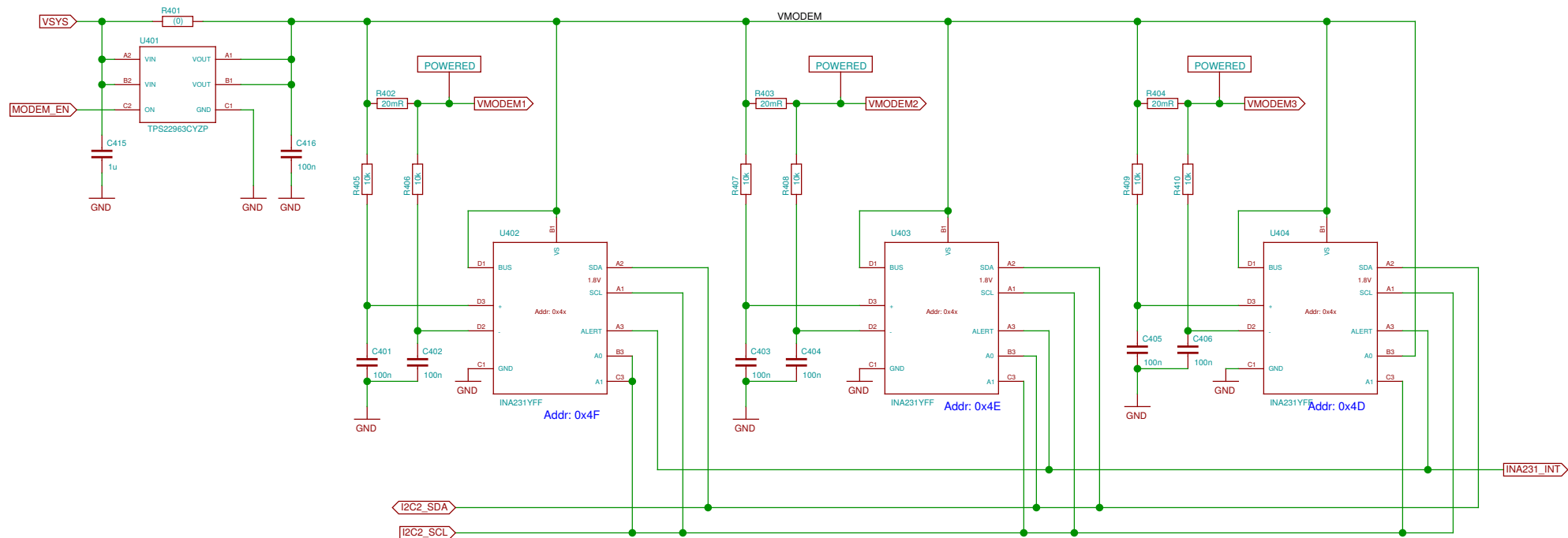

SIM current sensing

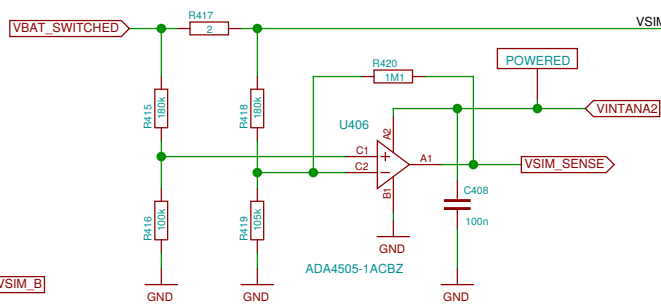

SIM power supply

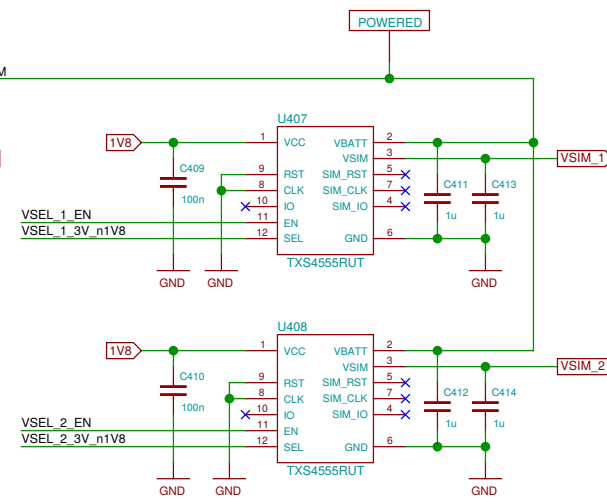

SIM power selection

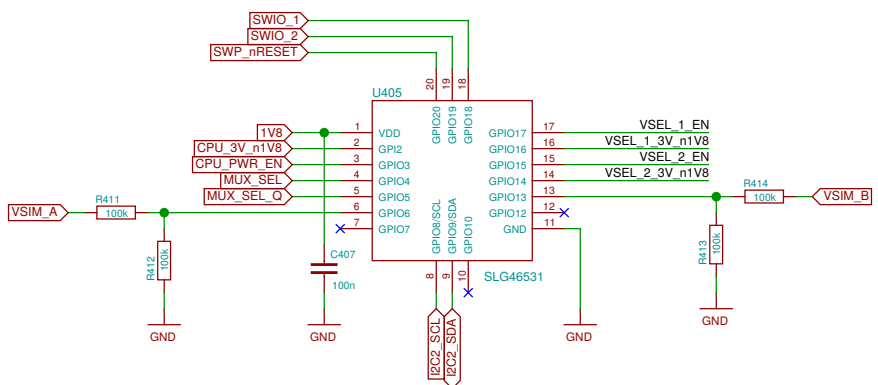

TODO: update SLG design for changed pins

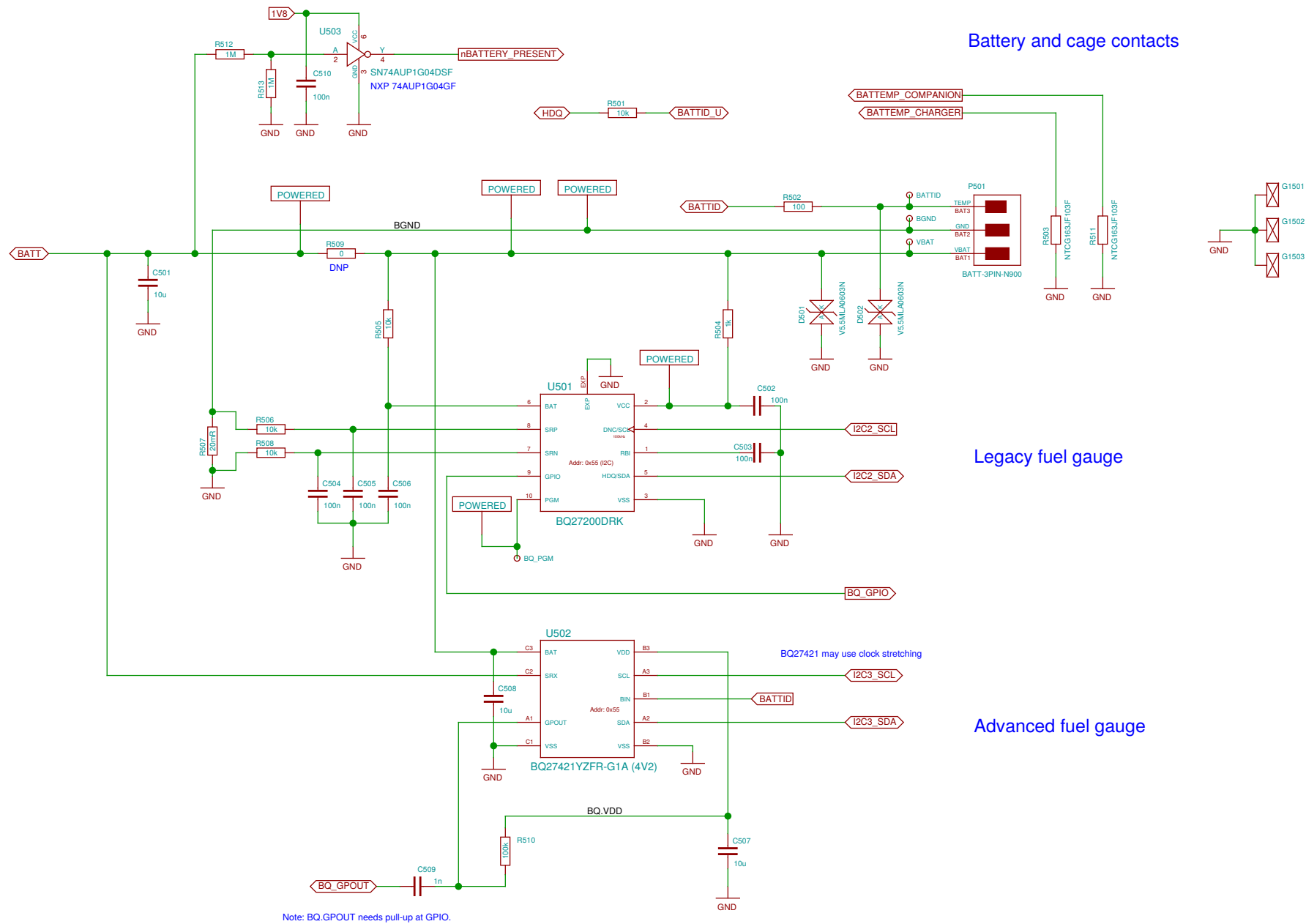

Battery and cage contacts

Legacy fuel gauge

Advanced fuel gauge

Note: BQ.GPOUT needs pull-up at GPIO.

Sheet: /Fuel Gauge/		
File: neo900_SS_5.sch		
Title: Fuel Gauge		
Size: A3	Date: 2016-10-28 21:16:24	Rev:
Plotted by eeshow 96ef3e0+ 20161030-17:20Z		Id: 5/37

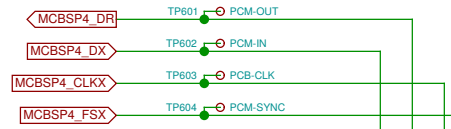
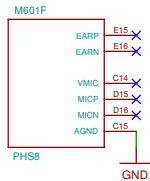

TODO: TBD

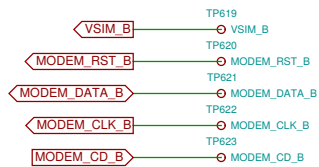

TODO: B-SIM bus FFS

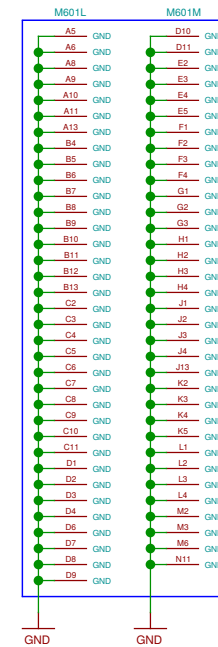
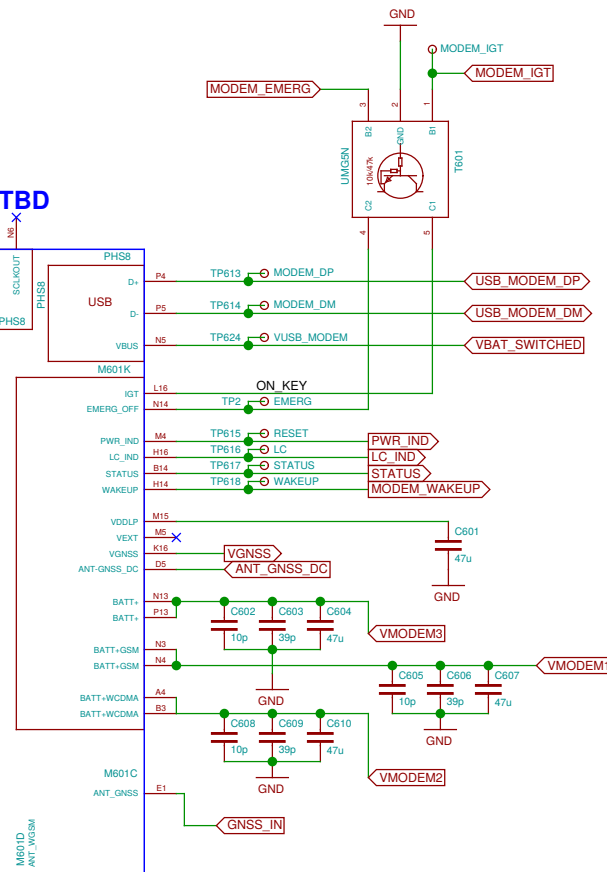
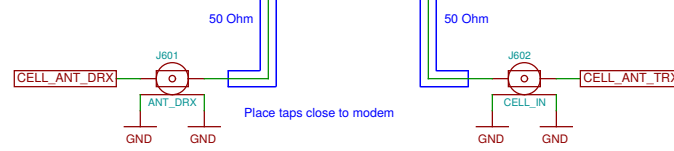
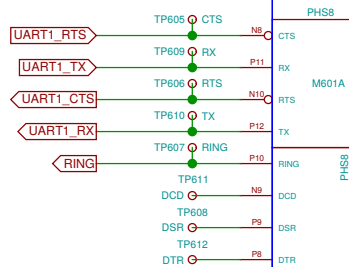
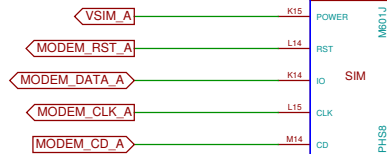

Sheet: /3G/4G Modem + SIM/		
File: neo900_SS_6.sch		
Title: 3G/4G Modem + SIM		
Size: A3	Date: 2016-10-28 21:16:24	Rev:
Plotted by eeshow 96ef3e0+ 20161030-17:20Z		Id: 6/37

Note: MODEM_CD_* (CCIN) is 1.8 V compatible.

Small logic gates are placed in close vicinity and share the bypass capacitor.

The FSA2866s operate at 3.3 V, for compatibility with Class B (2.7-3.3 V). The control inputs nOE and SEL are still 1.8 V compatible.

The delay timing is approximative. NXP provide the following formula: $t_w = K * R * C = \text{approx. } 500 \text{ ms}$ for K estimated to be 0.5.

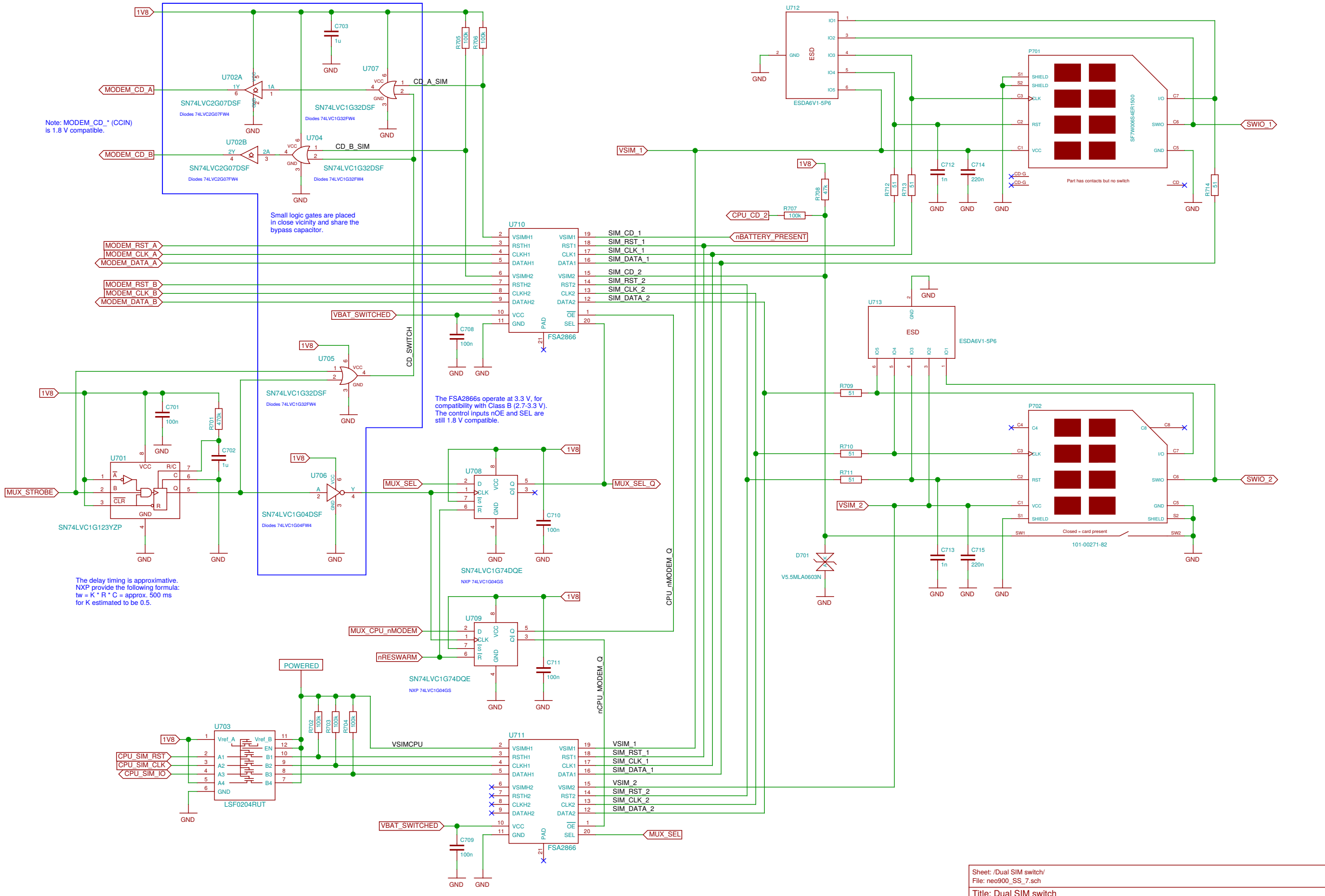

Sheet: /Dual SIM switch/		
File: neo900_SS_7.sch		
Title: Dual SIM switch		
Size: A3	Date: 2016-10-28 21:16:24	Rev:
Plotted by eeshow 96ef3e0+ 20161030-17:20Z		Id: 7/37

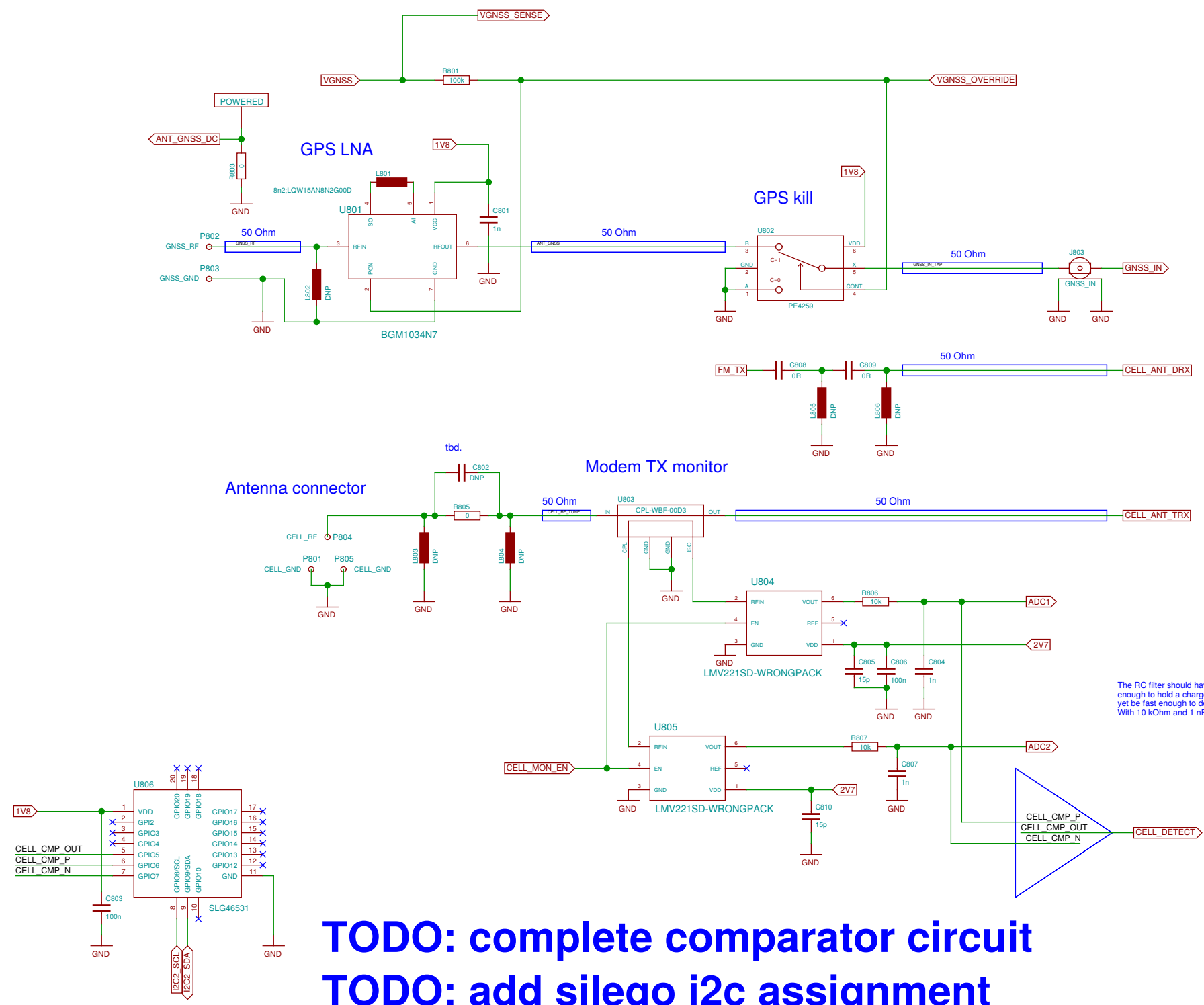

The RC filter should have C large enough enough to hold a charge in pulsed operation, yet be fast enough to detect short activity. With 10 kOhm and 1 nF, we get about 16 kHz.

TODO: complete comparator circuit
TODO: add silego i2c assignment

Sheet: /Antenna connections/ File: neo900_SS_8.sch		
Title: Antenna connections		
Size: A3	Date: 2016-10-28 21:16:24	Rev:
Plotted by eeshow 96ef3e0+ 20161030-17:20Z		Id: 8/37

TODO: assign footprints for c-spring contacts

WLAN/BT antenna

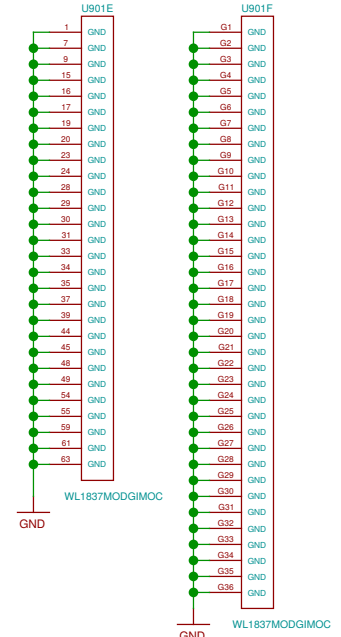
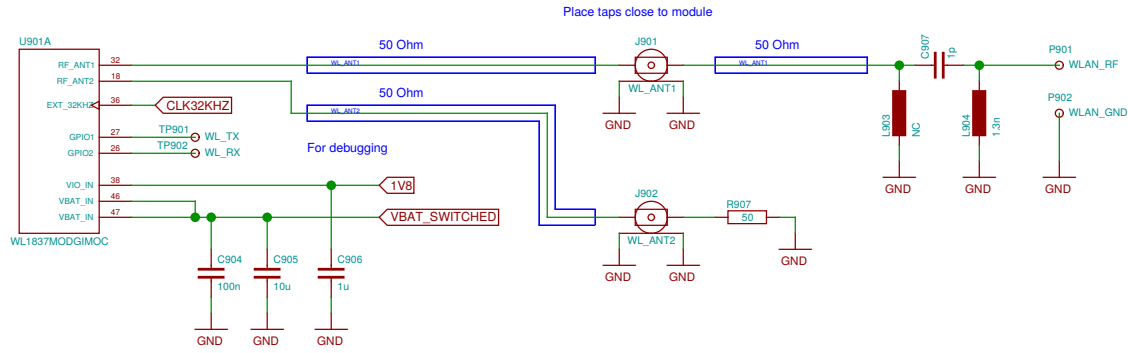

WLAN

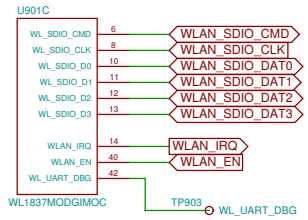

Bluetooth

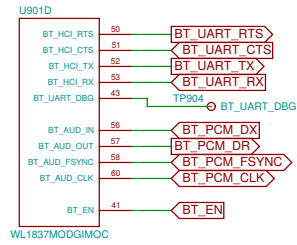

Reserved / Debugging

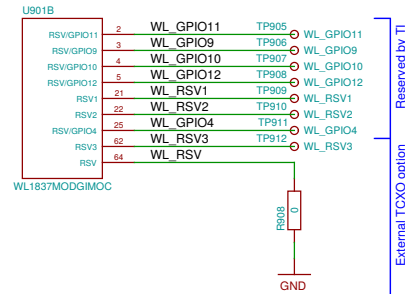

FM Radio (TX/RX)

TODO: check caps

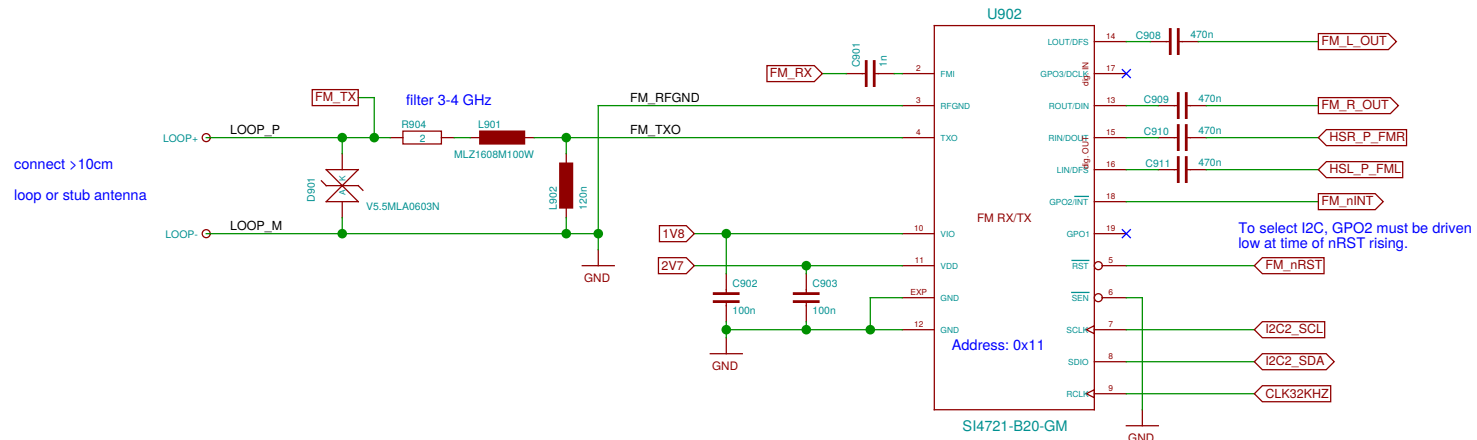

SI4705 is pin compatible (mostly) but RX-only

Sheet: /WLAN, Bluetooth, FM/		
File: neo900_SS_9.sch		
Title: WLAN, Bluetooth, FM		
Size: A3	Date: 2016-10-28 23:06:03	Rev:
Plotted by eeshow 96ef3e0+		20161030-17:20Z
Id: 9/37		

Acceleration (legacy)

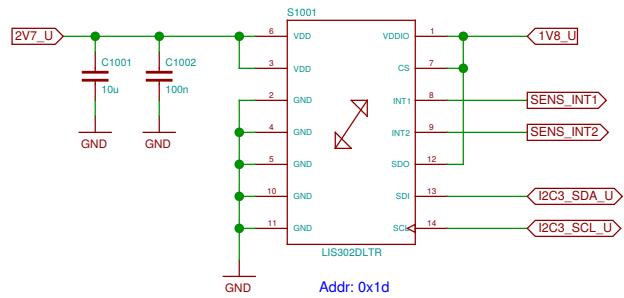

Pressure, humidity

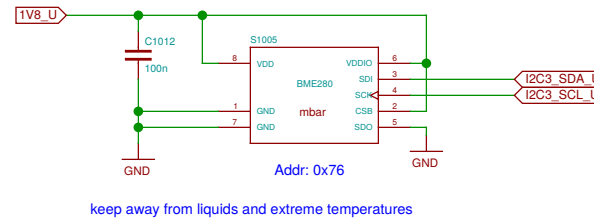

9-axis (acceleration, gyroscope, magnetometer)

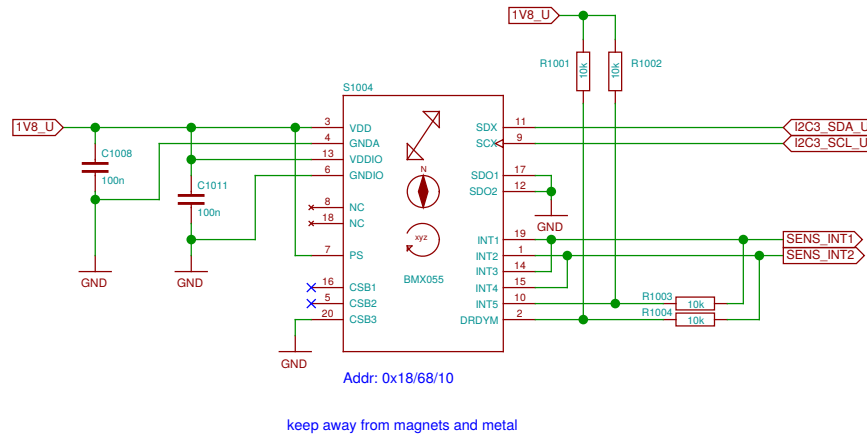

Sheet: /Sensors/		
File: neo900_SS_10.sch		
Title: Sensors		
Size: A3	Date: 2016-10-28 21:16:24	Rev:
Plotted by eeshow 96ef3e0+ 20161030-17:20Z		Id: 10/37

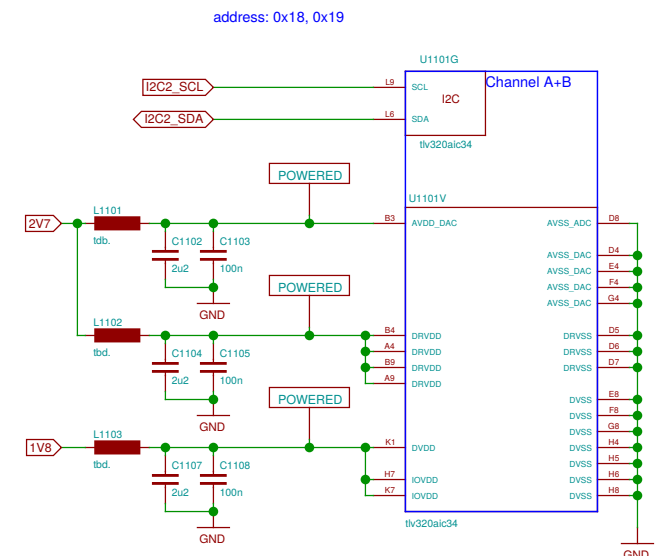
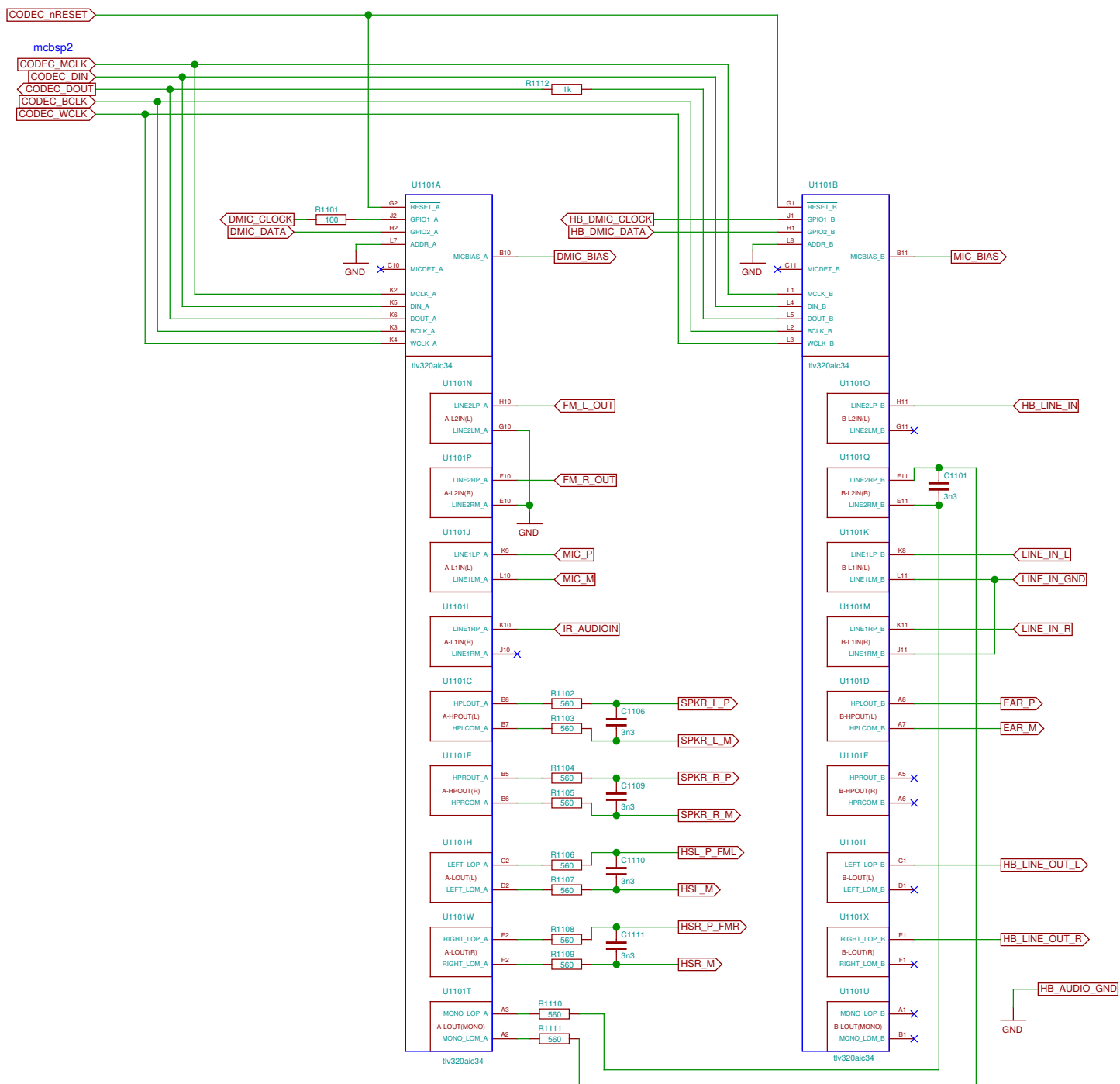

Sheet: /Audio Codec/ File: neo900_SS_11.sch		
Title: Audio Codec		
Size: A3	Date: 2016-10-30 17:08:14	Rev:
Plotted by eeshow 96ef3e0+ 20161030-17:20Z		Id: 11/37

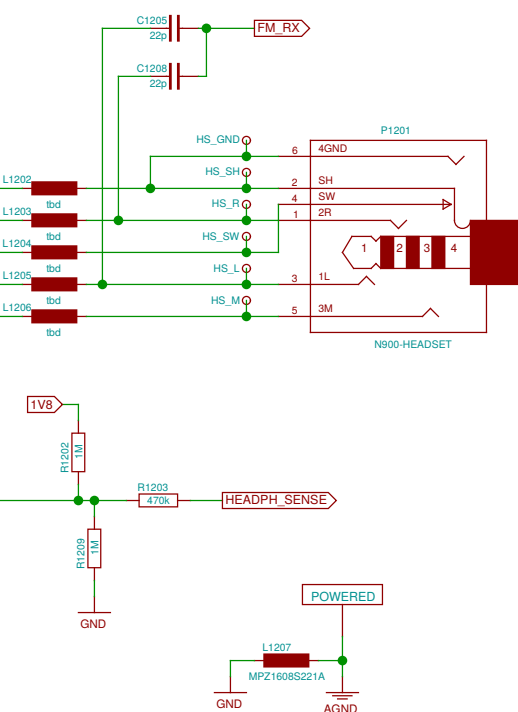
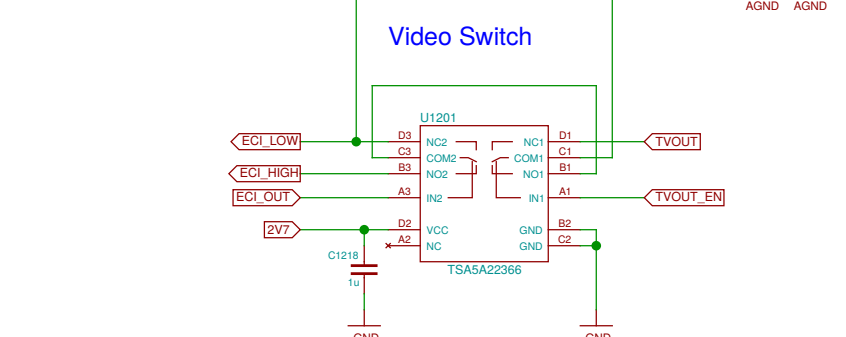
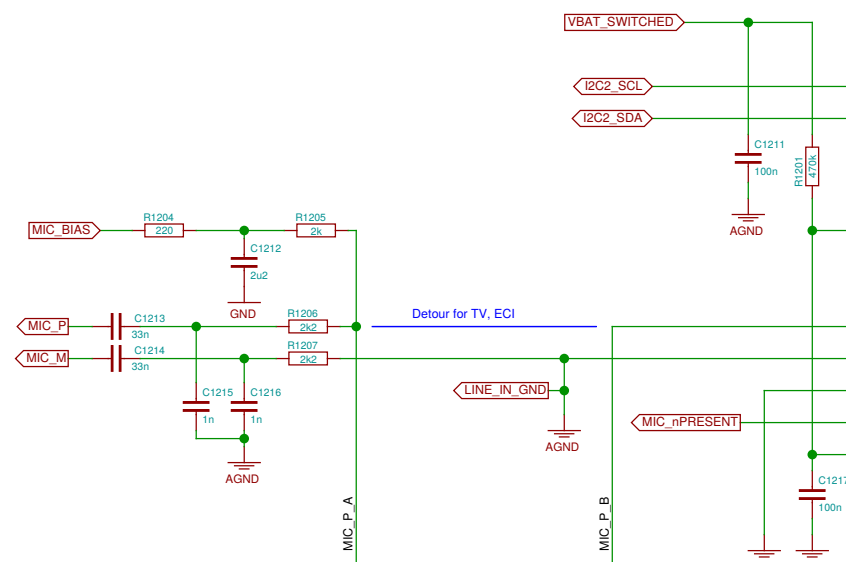
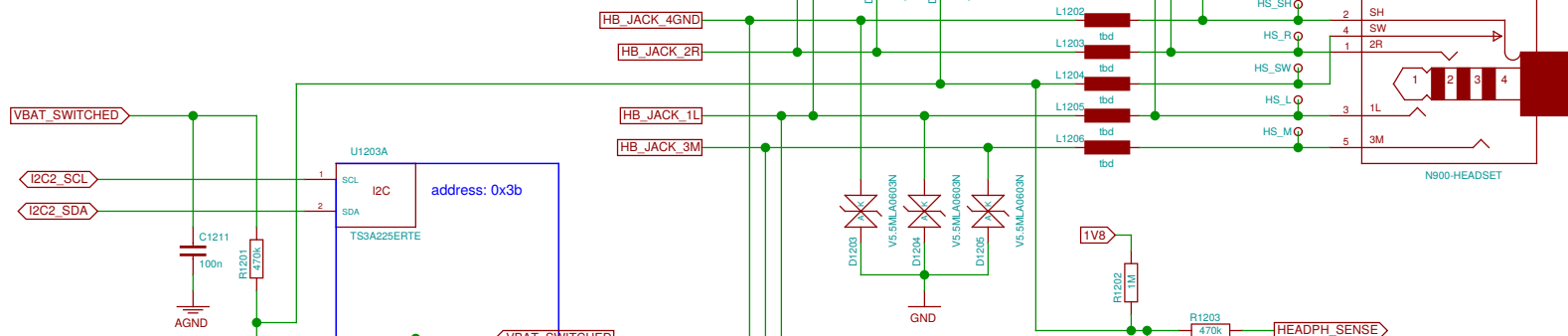
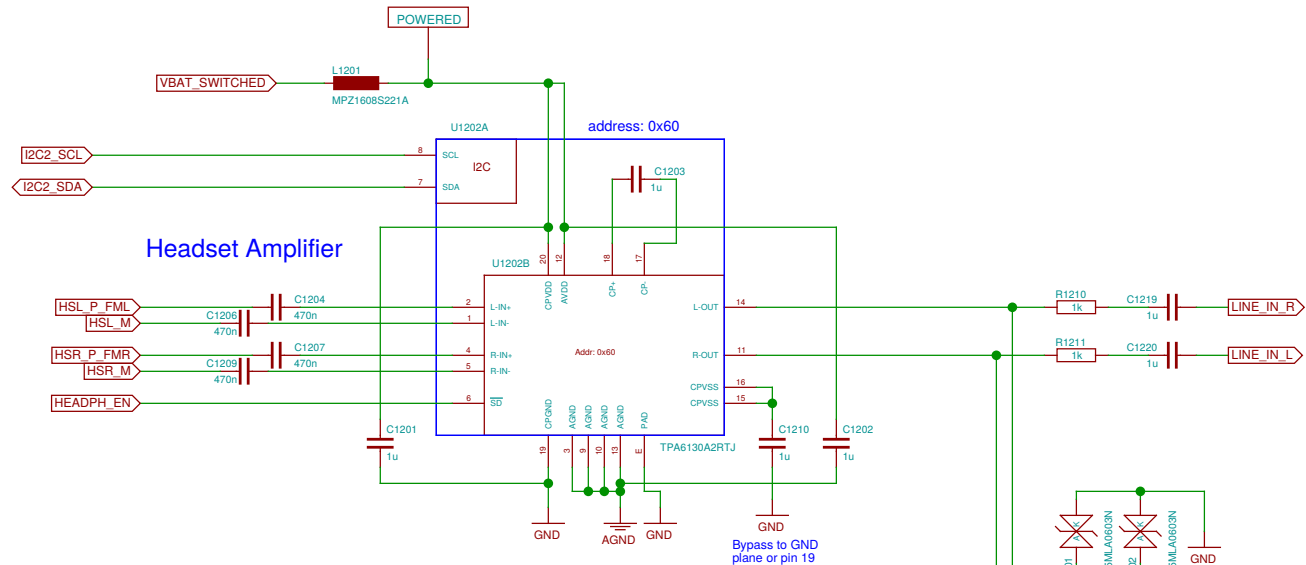

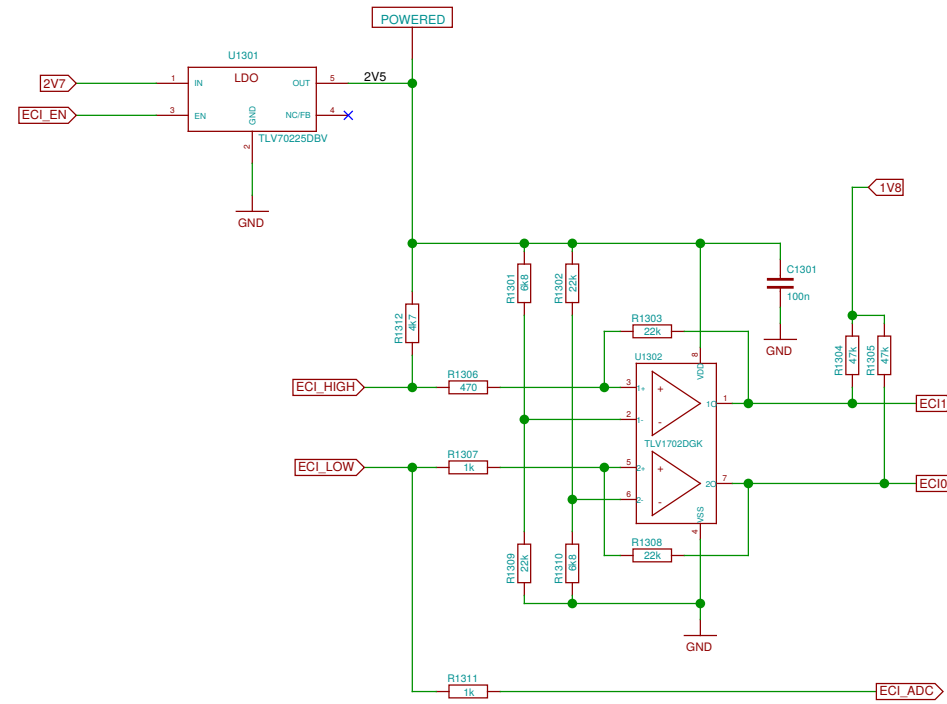

Sheet: /ECI/		
File: neo900_SS_13.sch		
Title: ECI		
Size: A3	Date: 2016-10-28 21:16:24	Rev:
Plotted by eeshow 96ef3e0+ 20161030-17:20Z		Id: 13/37

Hands-free

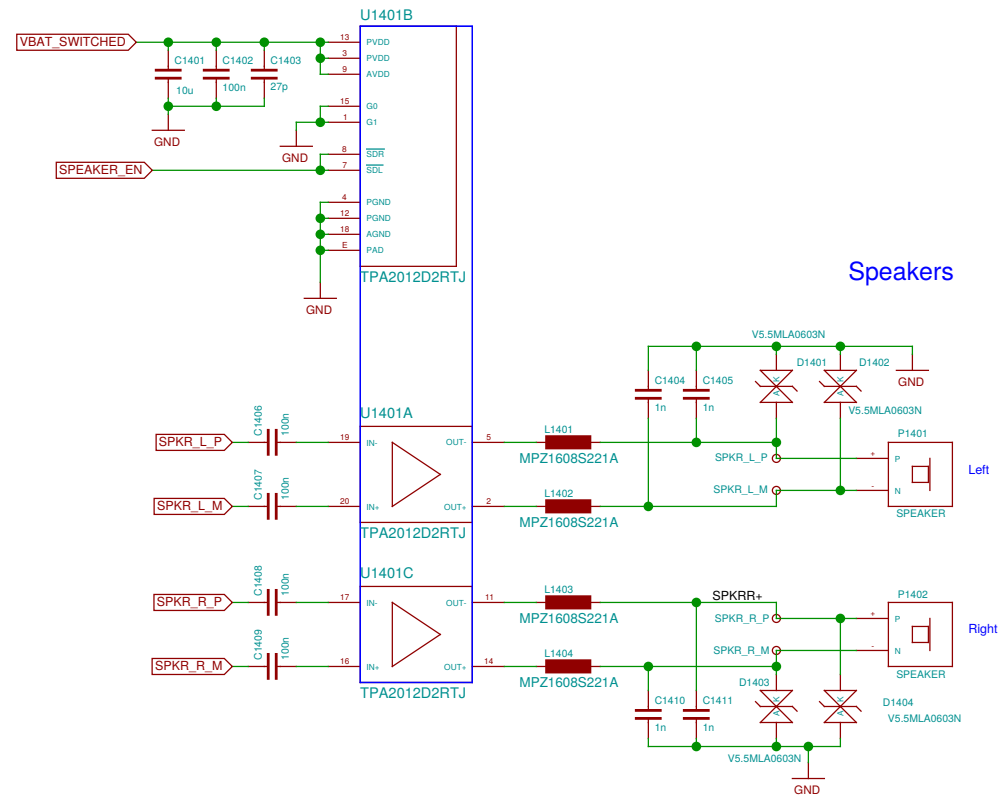

Digital Microphones

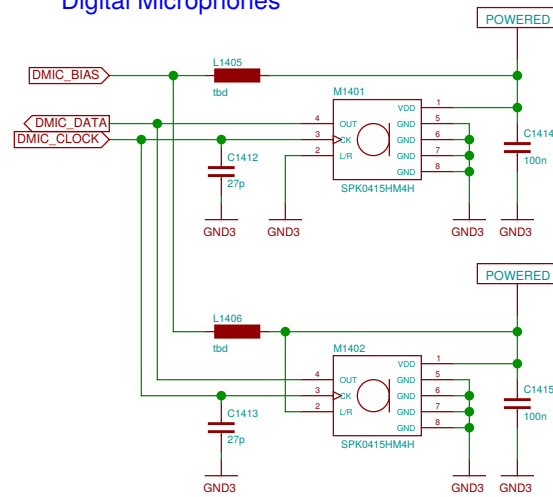

Sheet: /Audio Handsfree/		
File: neo900_SS_14.sch		
Title: Audio Handsfree		
Size: A3	Date: 2016-10-28 23:06:03	Rev:
Plotted by eeshow 96ef3e0+ 20161030-17:20Z		Id: 14/37

Shield Contacts on UPPER

For the display

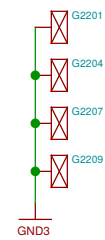

For the key mat

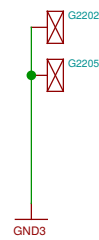

For the "key frame hook"

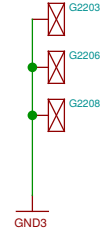

Stylus detect

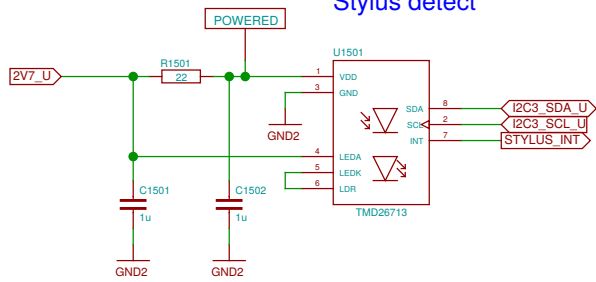

Vibramotor

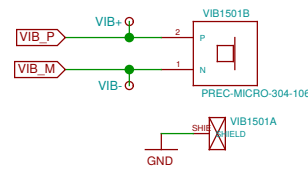

Slide sensor

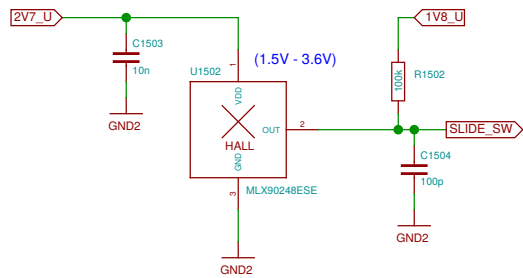

Sheet: Misc/ File: neo900_SS_15.sch		
Title: Misc		
Size: A3	Date: 2016-10-28 21:16:24	Rev:
Plotted by eeshow 96ef3e0+ 20161030-17:20Z		Id: 15/37

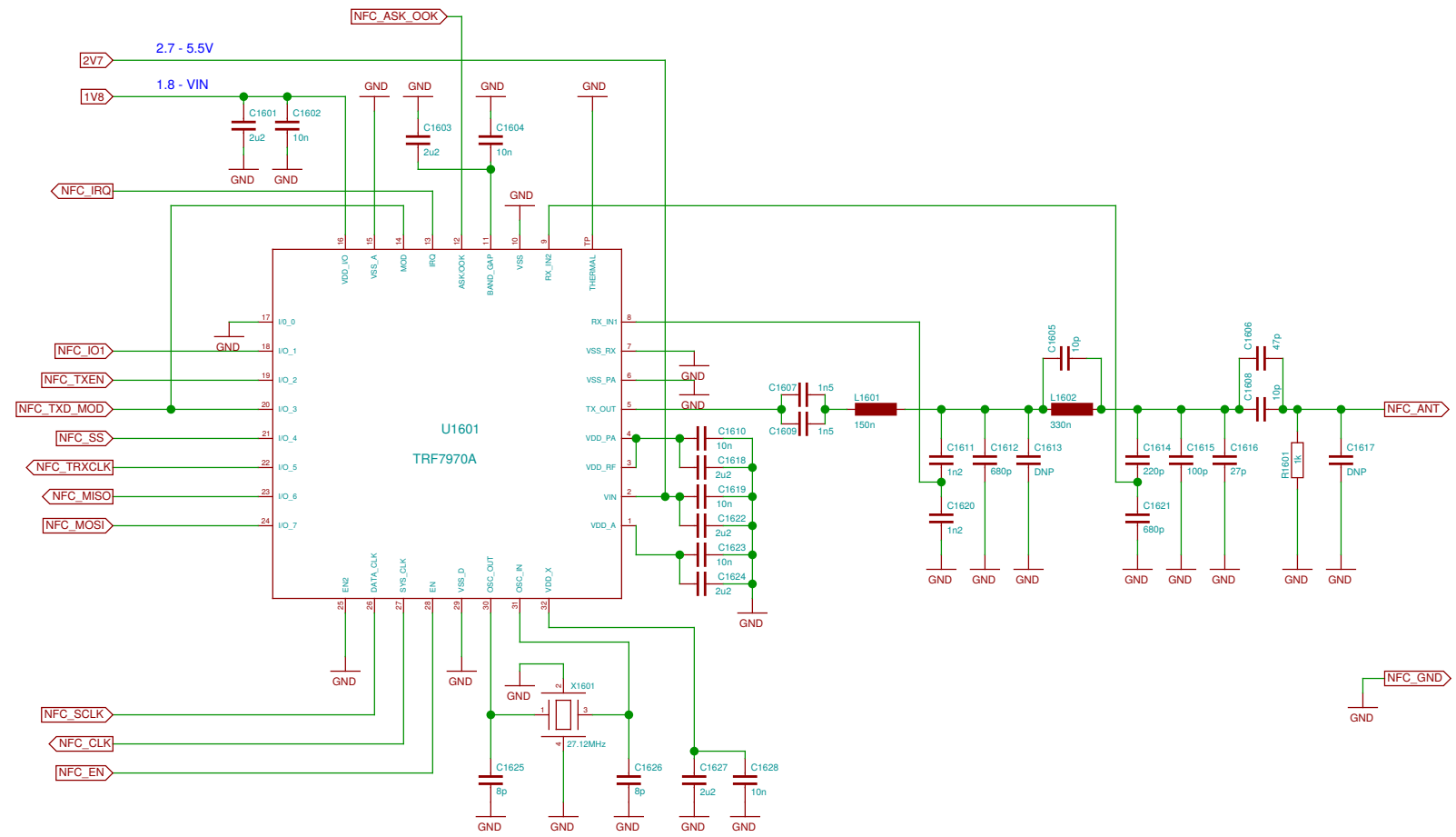

Some choices, 3.2 x 2.6 mm, 8-10 pF:
 NDK NX3225GA-27.12M-STD-CRG-2
 NDK NX3225SA-27.12M-STD-CSR-3
 Tattien XXCCEINANF-27.120000

Sheet: /RFID/NFC Reader/		
File: neo900_SS_16.sch		
Title: RFID/NFC Reader		
Size: A3	Date: 2016-10-28 21:16:24	Rev:
Plotted by eeshow 96ef3e0+ 20161030-17:20Z		Id: 16/37

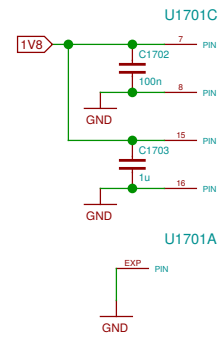
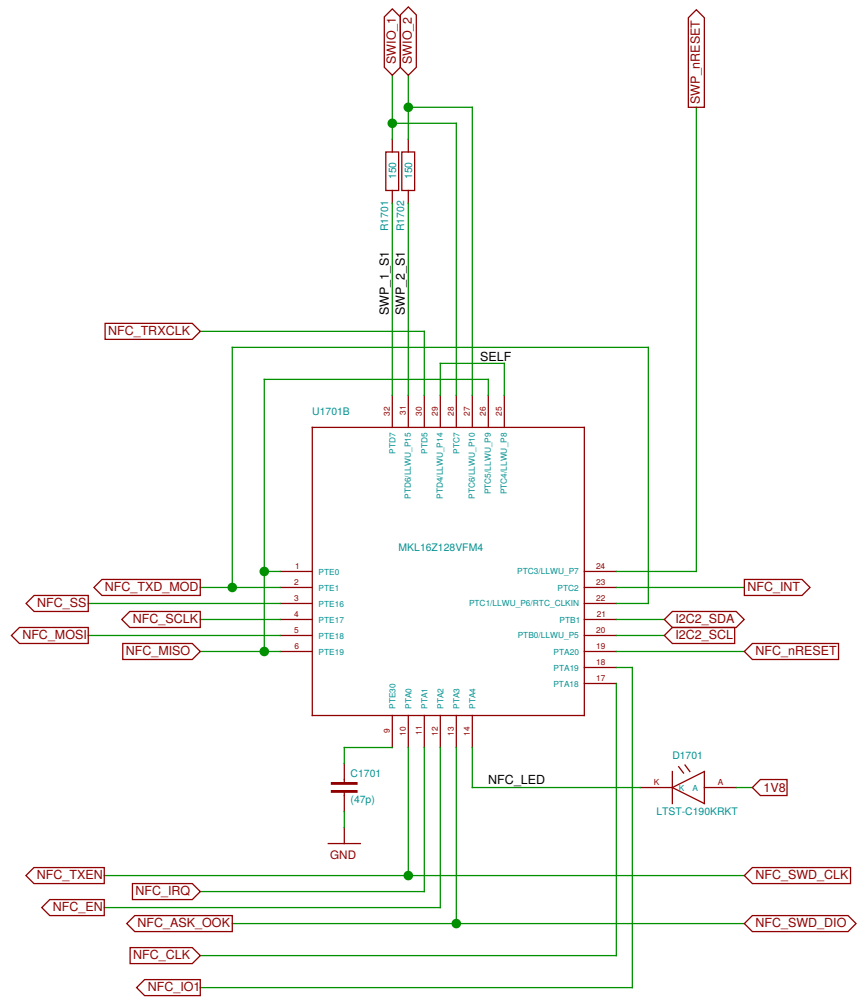

Sheet: /RFID/NFC Controller/		
File: neo900_SS_17.sch		
Title: RFID/NFC Controller		
Size: A3	Date: 2016-10-28 21:16:24	Rev:
Plotted by eeshow 96ef3e0+		20161030-17:20Z
Id: 17/37		

LOWER-BOB Interconnect (LOWER side)

Defined in the Hackerbus specification, <http://neo900.org/stuff/papers/hb.pdf>

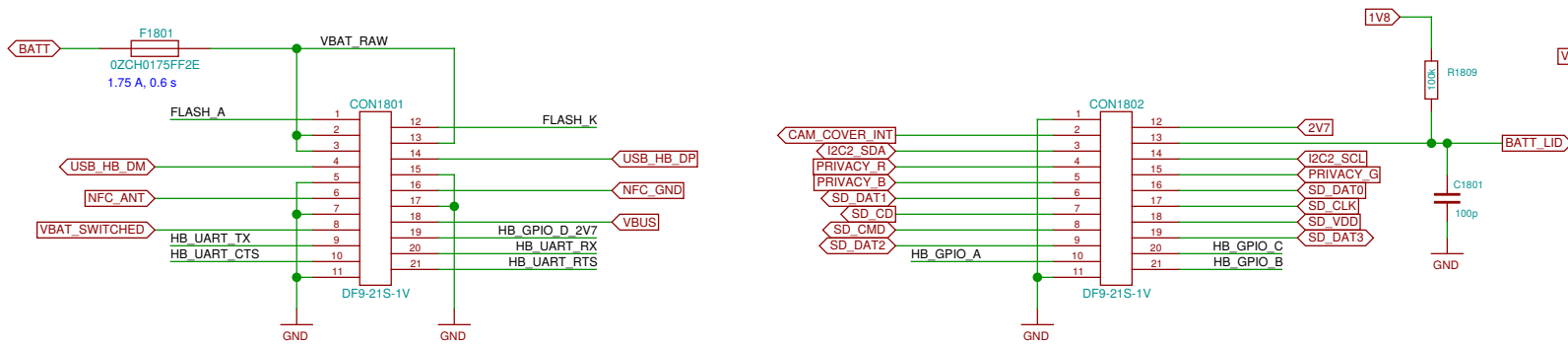

Flash/Torch

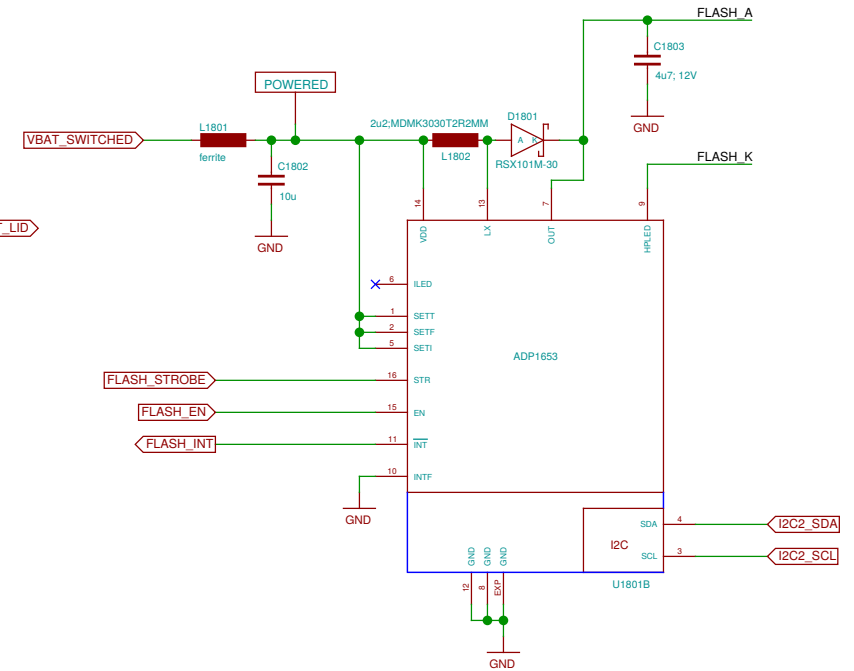

Level shifters for Hackerbus GPIO and UART

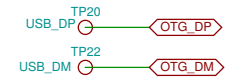
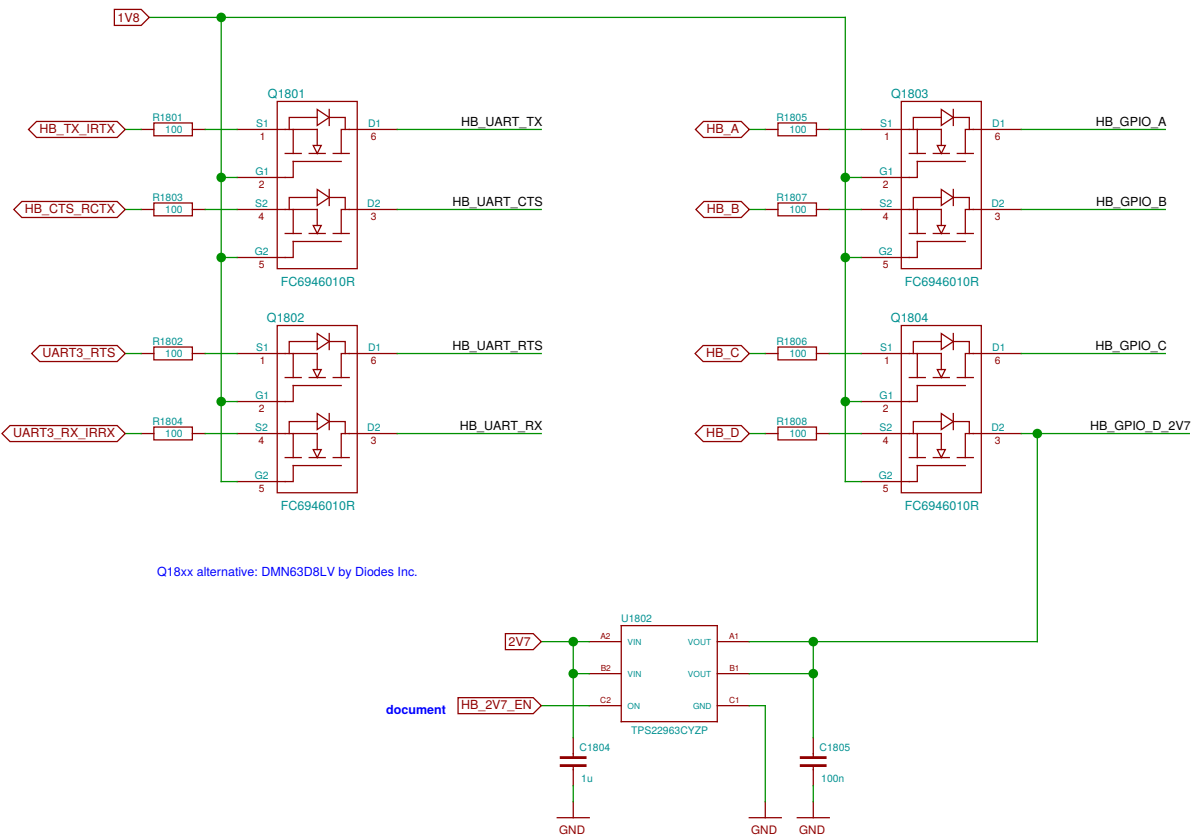

Patchfield



Sheet: /Hackerbus/		
File: neo900_SS_18.sch		
Title: Hackerbus		
Size: A3	Date: 2016-10-30 18:23:57	Rev:
Plotted by eeshow 96ef3e0+ 20161030-17:20Z		Id: 18/37

Missing 6x 2R for alternate function select (do we have the space for ca. 2.5 x 5mm?)

TODO: update D1901 footprint

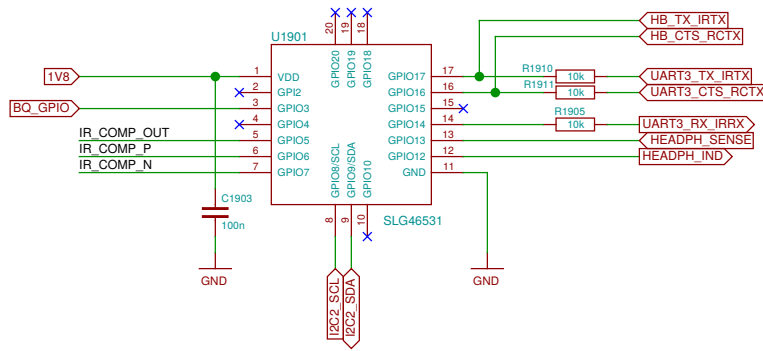
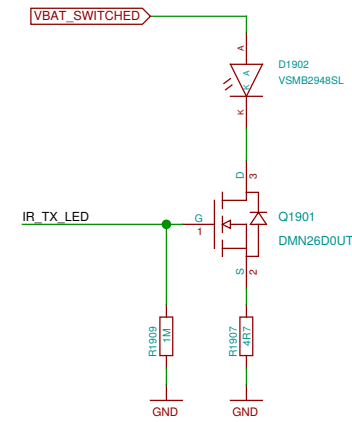
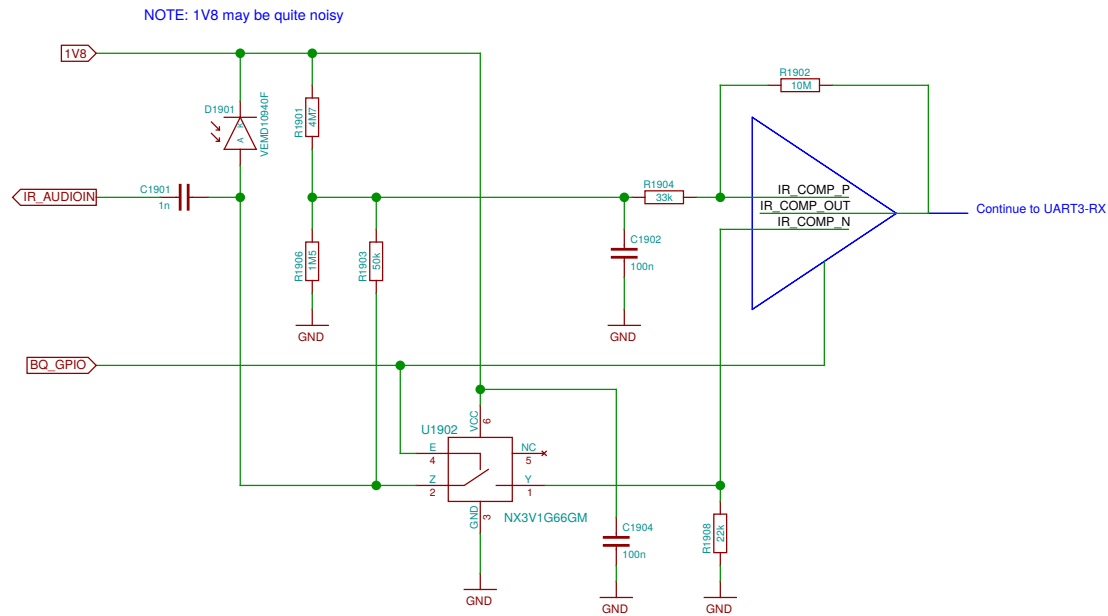

Sheet: /Infrared/ File: neo900_SS_19.sch		
Title: Infrared		
Size: A3	Date: 2016-10-29 17:39:34	Rev:
Plotted by eeshow 96ef3e0+ 20161030-17:20Z		Id: 19/37

This is just the collection of signals we have. Proper assignment still pending.

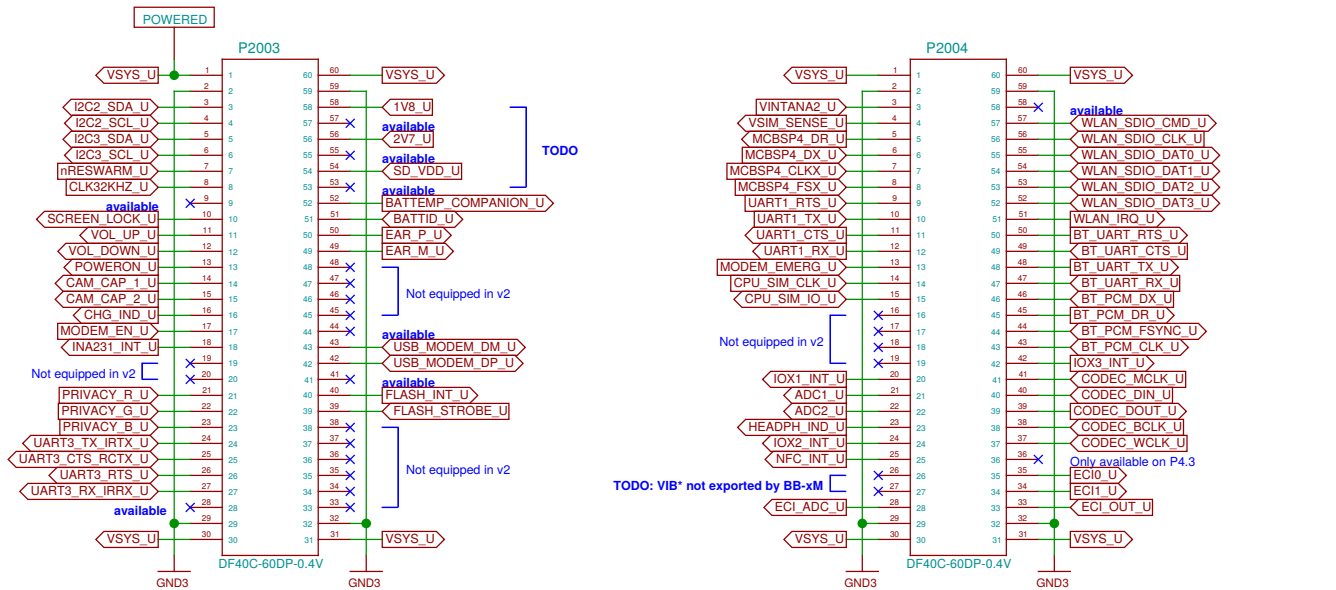

UPPER
LOWER

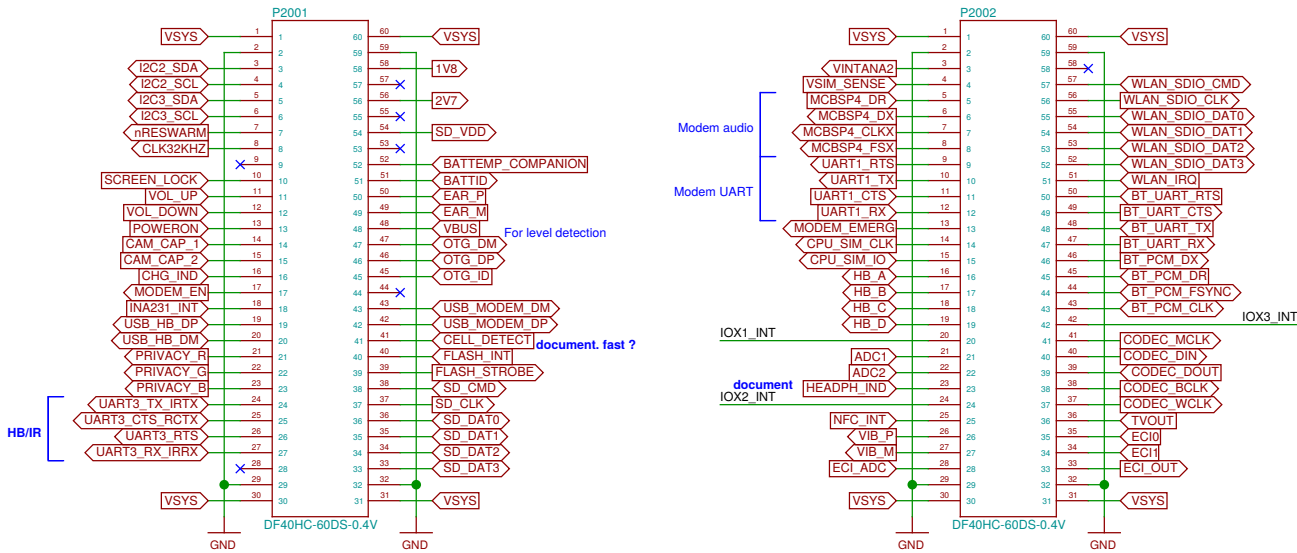

Current rating per contact: 0.3 A

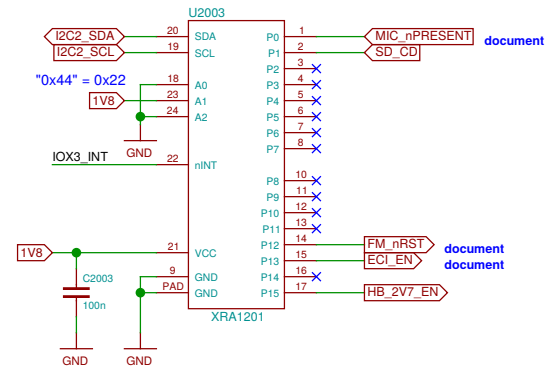
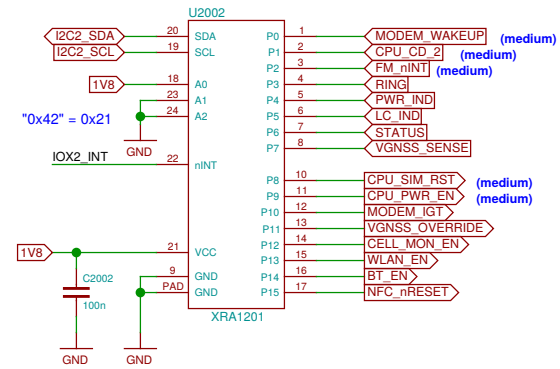
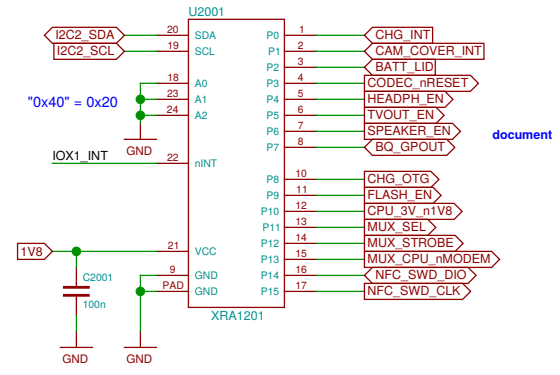

Camera Cover detect

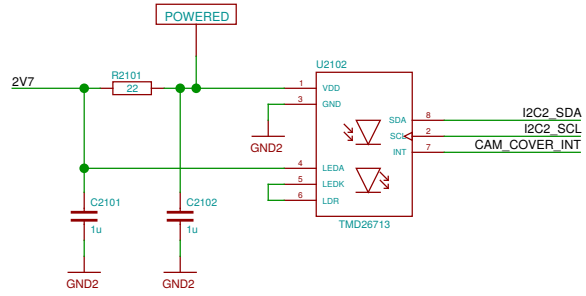

Battery Cover detect

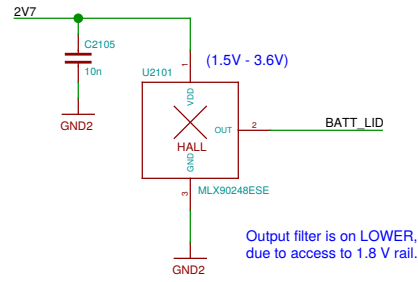

Memory card holder

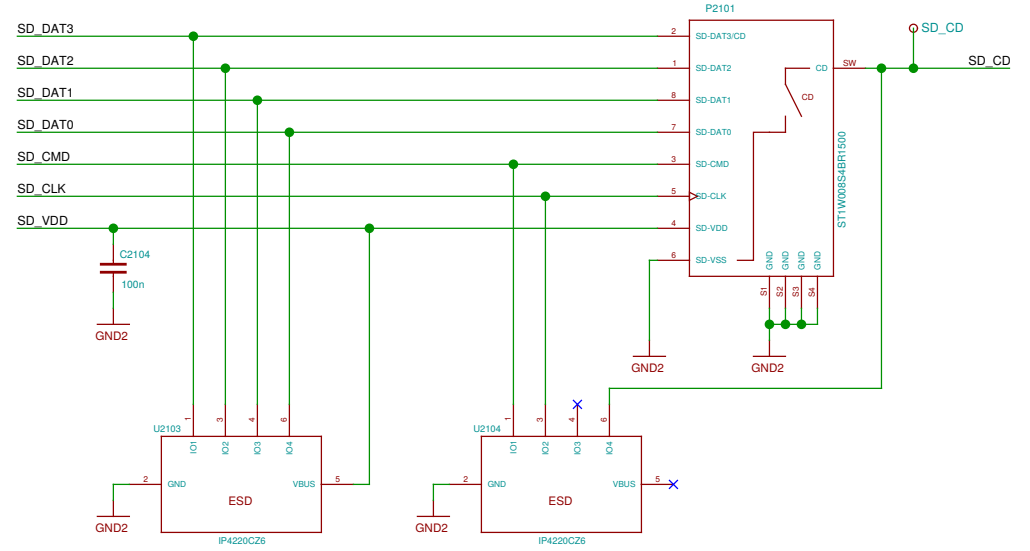

LOWER-BOB Interconnect (BOB side)

Defined in the Hackerbus specification, <http://neo900.org/stuff/papers/hb.pdf>

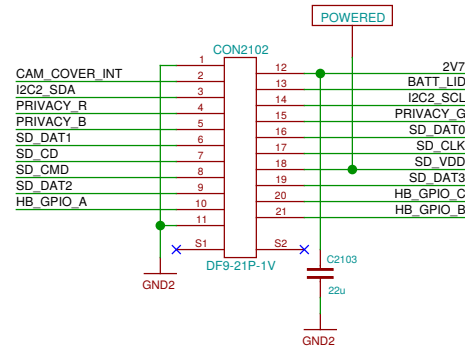
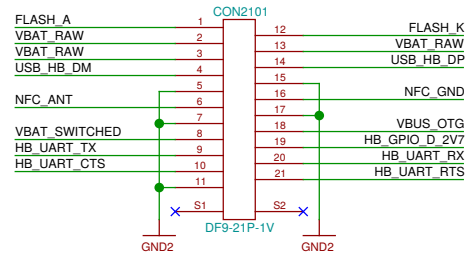

Camera flash

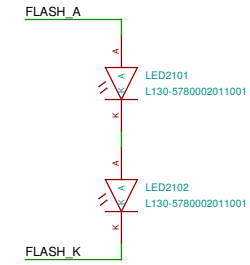

Hackerbus

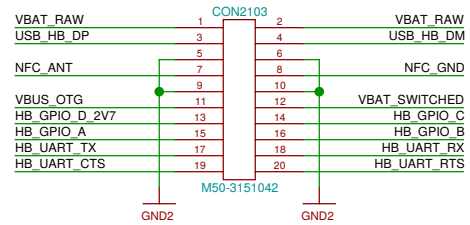

Privacy LED

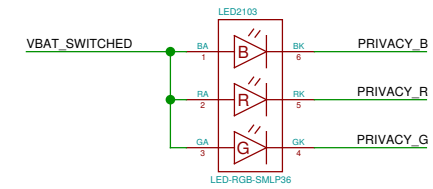

Sheet: /uSD Breakout Board/ File: neo900_SS_21.sch		
Title: uSD Breakout Board		
Size: A3	Date: 2016-10-28 21:16:24	Rev:
Plotted by eeshow 96ef3e0+ 20161030-17:20Z		Id: 21/37

TODO: consider sheet for deletion

Sheet: /empty/ File: neo900_SS_22.sch		
Title: empty		
Size: A3	Date: 2016-10-28 21:16:24	Rev:
Plotted by eeshow 96ef3e0+ 20161030-17:20Z		Id: 22/37

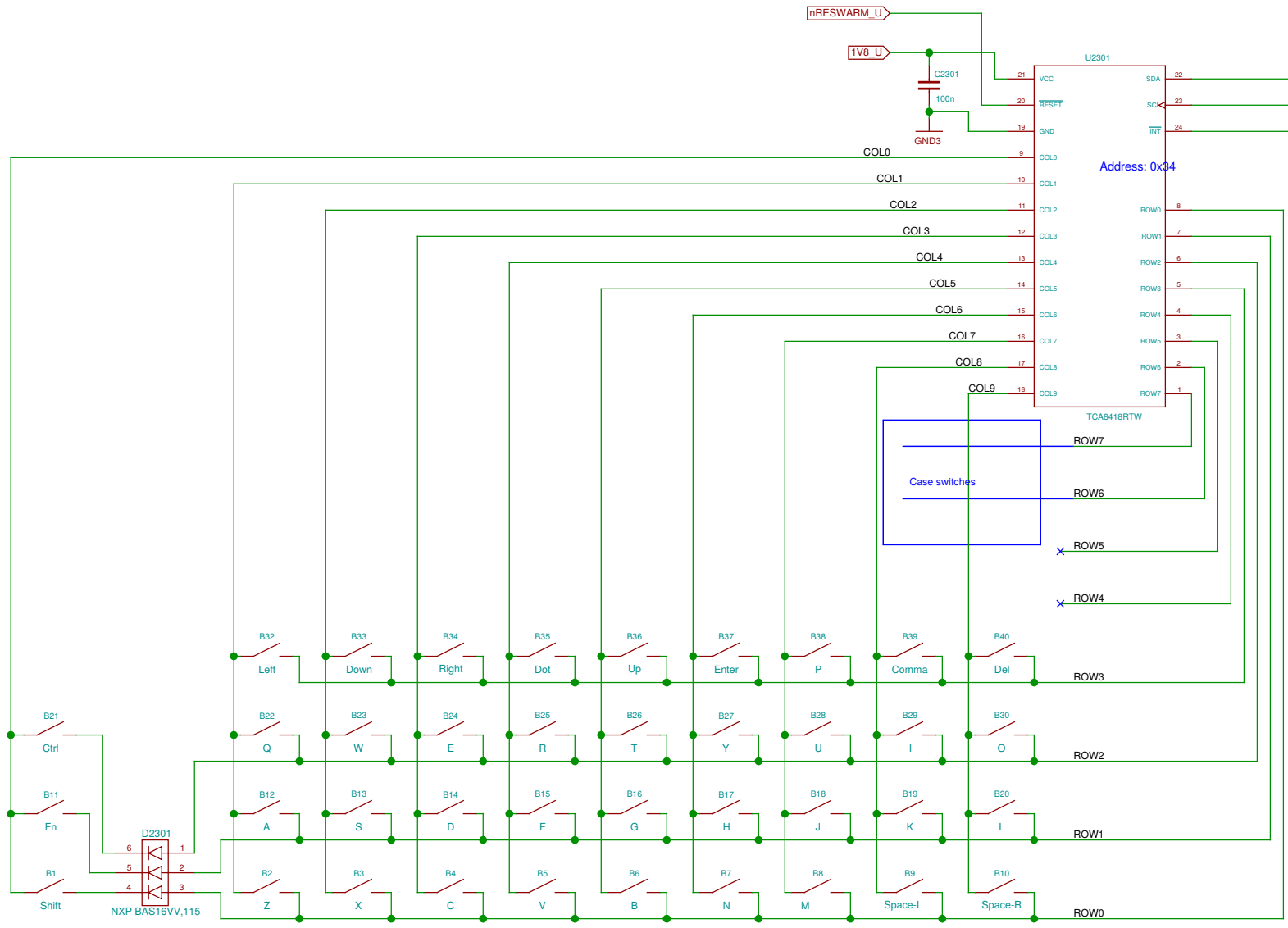

Alternative: Diodes Inc. BAS16VV-7
 Warning: Diodes Inc. have cathodes on pin 1 side, NXP anodes !

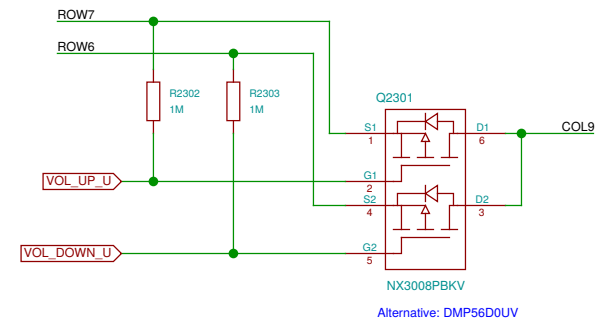
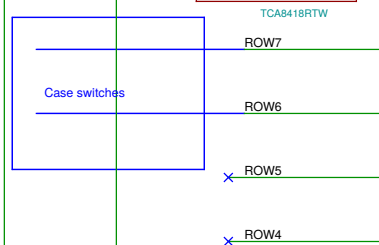

Sheet: /Keypad/ File: neo900_SS_23.sch		
Title: Keypad		
Size: A3	Date: 2016-10-31 06:28:58	Rev:
Plotted by eeshow 96ef3e0+ 20161030-17:20Z		Id: 23/37

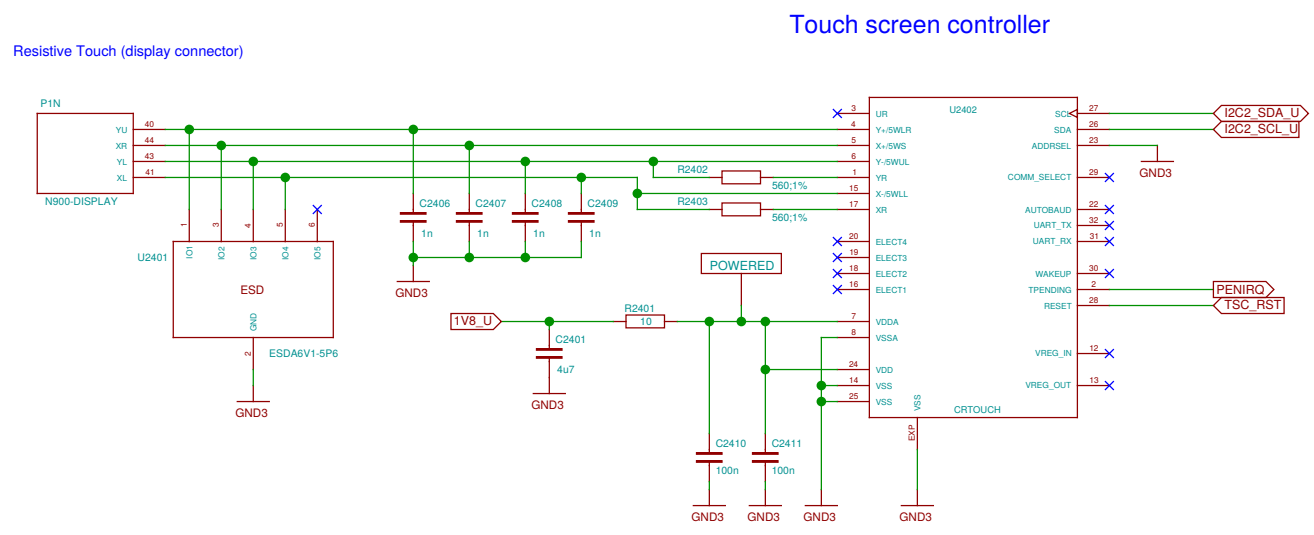

Sheet: /Display-Peripherals/		
File: neo900_SS_24.sch		
Title: Display-Peripherals		
Size: A3	Date: 2016-10-28 21:16:24	Rev:
Plotted by eeshow 96ef3e0+ 20161030-17:20Z		Id: 24/37

TWL4030, GPIO6/PWM0, ball M4

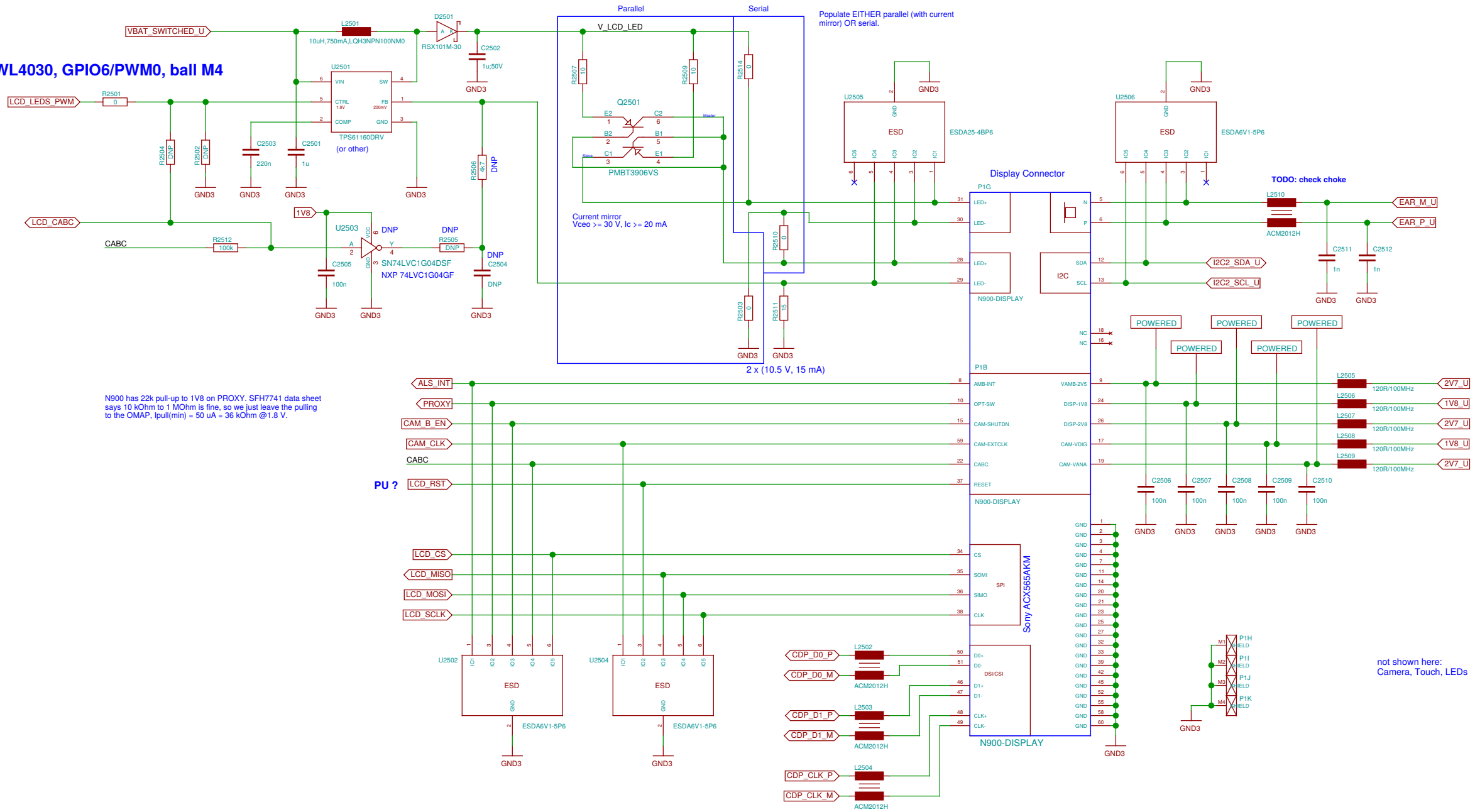

N900 has 22k pull-up to 1V8 on PROXY. SFH7741 data sheet says 10 kOhm to 1 MOhm is fine, so we just leave the pulling to the OMAP, Ipull(min) = 50 uA = 36 kOhm @ 1.8 V.

TODO: check choke

not shown here: Camera, Touch, LEDs

Sheet: /Display-Panel&Power/		
File: neo900_SS_25.sch		
Title: Display-Panel&Power		
Size: A3	Date: 2016-10-28 21:16:24	Rev:
Plotted by eeshow 96ef3e0+ 20161030-17:20Z		Id: 25/37

OMAP is not part of v2

Sheet: /CPU + PoP RAM/NAND/ File: neo900_SS_26.sch		
Title: CPU + PoP RAM/NAND		
Size: A3	Date: 2016-10-28 21:16:24	Rev:
Plotted by eeshow 96ef3e0+ 20161030-17:20Z		Id: 26/37

eMMC is not part of v2

Sheet: /eMMC/ File: neo900_SS_27.sch		
Title: eMMC		
Size: A3	Date: 2016-10-28 21:16:24	Rev:
Plotted by eeshow 96ef3e0+ 20161030-17:20Z		Id: 27/37

Companion chip (TPS65950) is not part of v2

Sheet: /PMU+Codec/ File: neo900_SS_28.sch		
Title: PMU+Codec		
Size: A3	Date: 2016-10-28 21:16:24	Rev:
Plotted by eeshow 96ef3e0+ 20161030-17:20Z		Id: 28/37

simple capless 400mA LDO for TPS65950 substitute
(only for prototype)

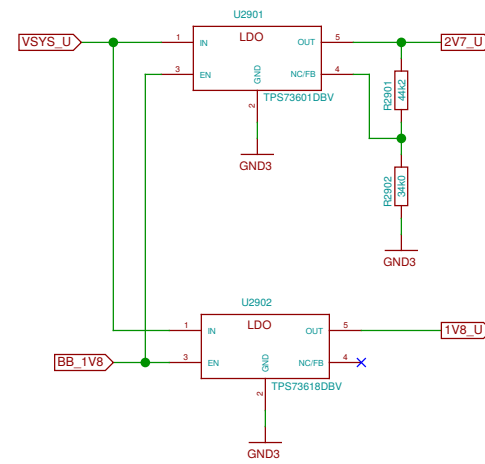

TODO: use REGEN ?

Sheet: /BB-XM Dummy (TWL4030)/		
File: neo900_SS_29.sch		
Title: BB-XM Dummy (TWL4030)		
Size: A3	Date: 2016-10-28 21:16:24	Rev:
Plotted by eeshow 96ef3e0+ 20161030-17:20Z		Id: 29/37

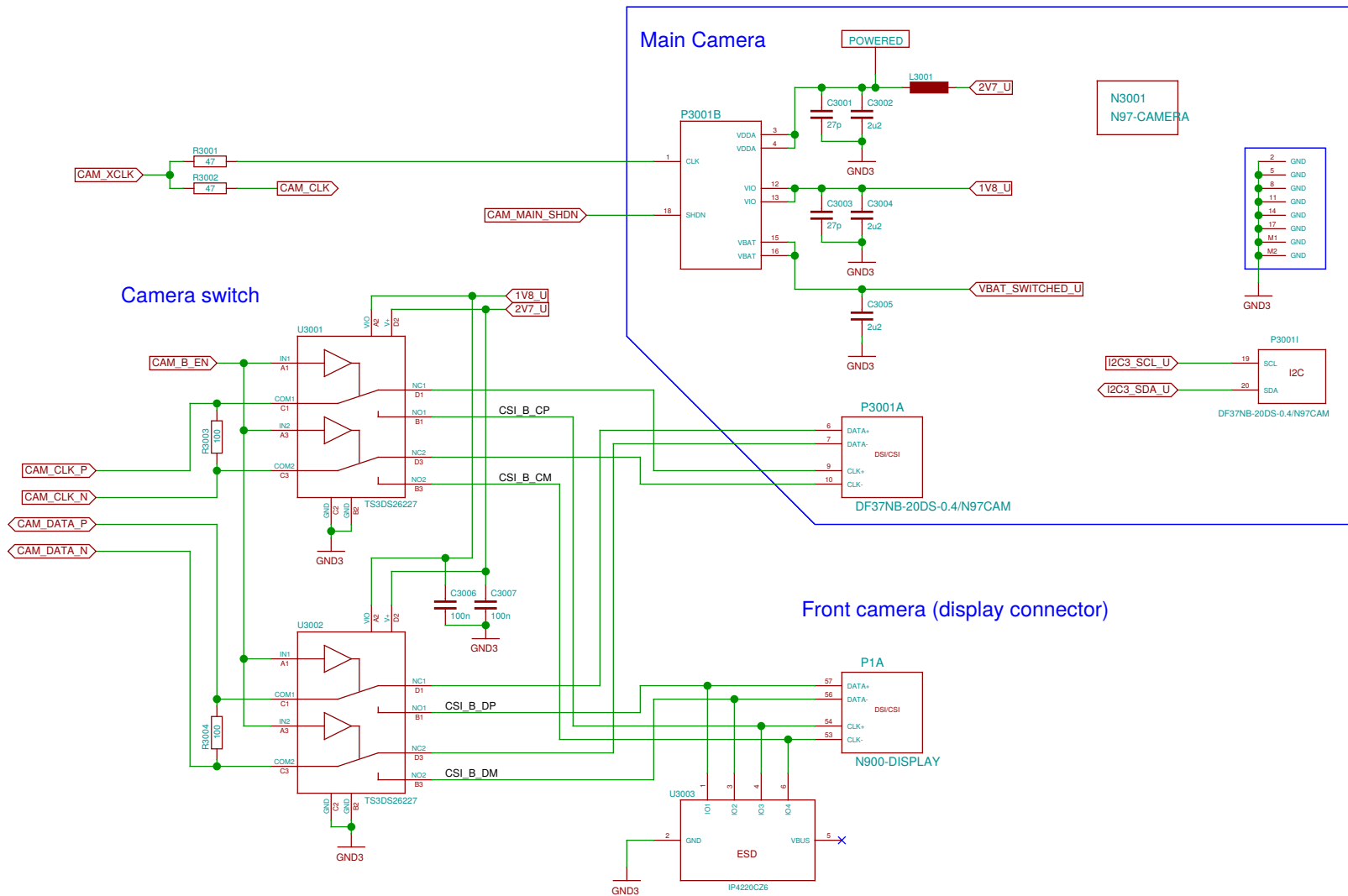

Sheet: /Camera/ File: neo900_SS_30.sch		
Title: Camera		
Size: A3	Date: 2016-10-28 21:16:24	Rev:
Plotted by eeshow 96ef3e0+ 20161030-17:20Z		Id: 30/37

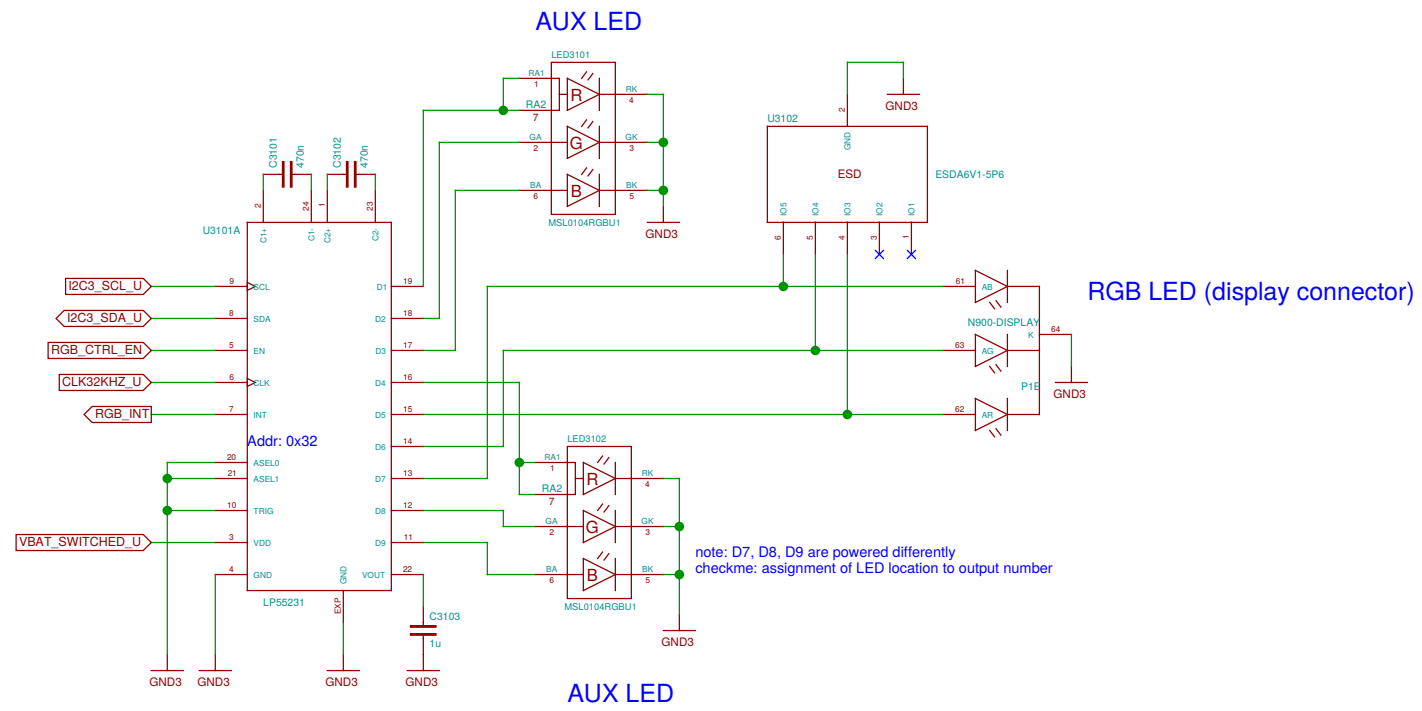

Sheet: /Fancy LEDs/		
File: neo900_SS_31.sch		
Title: Fancy LEDs		
Size: A3	Date: 2016-10-28 21:16:24	Rev:
Plotted by eeshow 96ef3e0+ 20161030-17:20Z		Id: 31/37

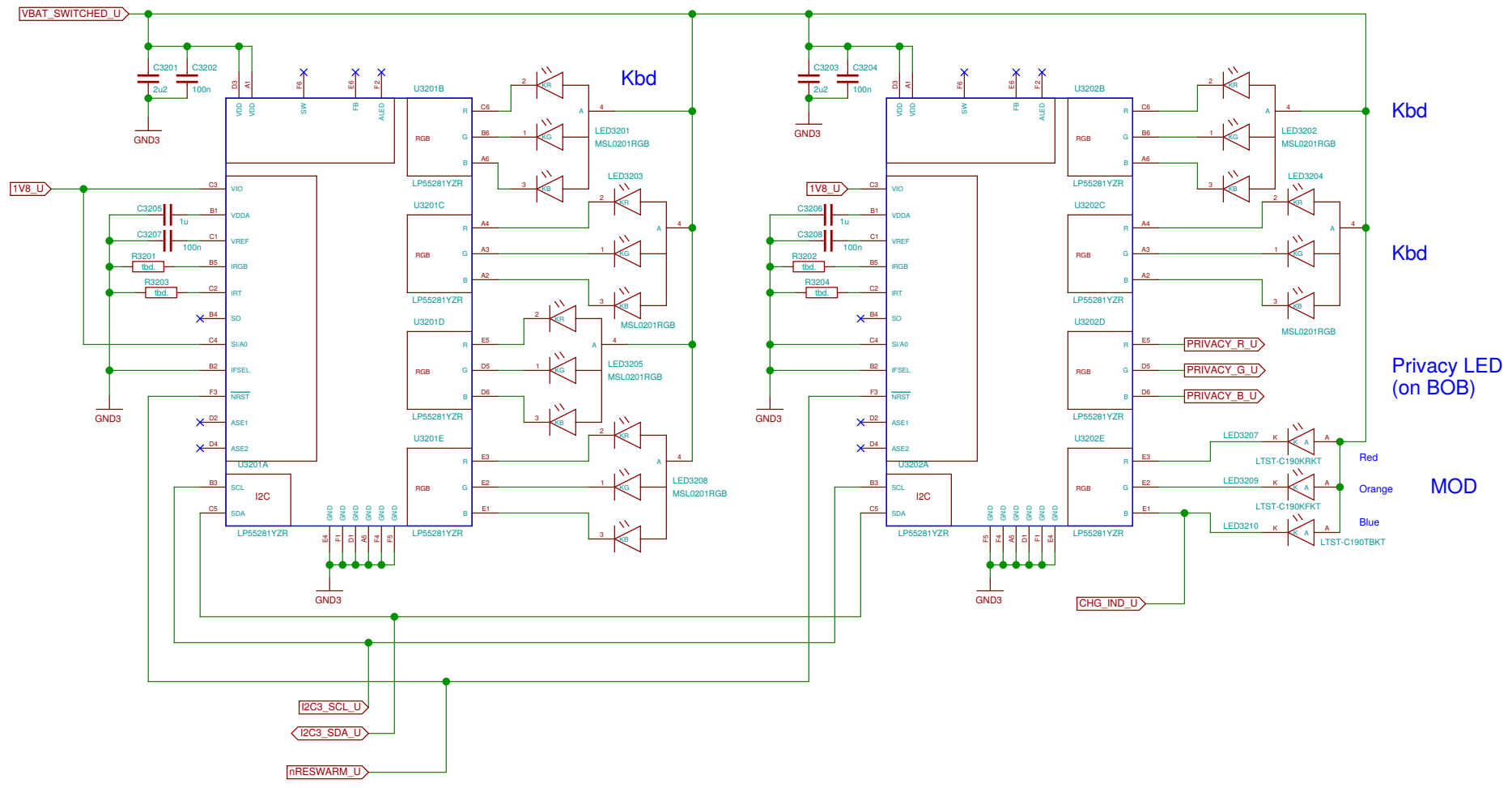

Sheet: /Basic LEDs/		
File: neo900_SS_32.sch		
Title: Basic LEDs		
Size: A3	Date: 2016-10-28 21:16:24	Rev:
Plotted by eeshow 96ef3e0+ 20161030-17:20Z		Id: 32/37

Cleaning up. The connections to BB-xM are on the next sheets.

connect to BB
by some Micro-USB cable

Modem USB

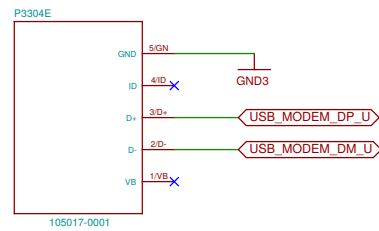

32 kHz clock

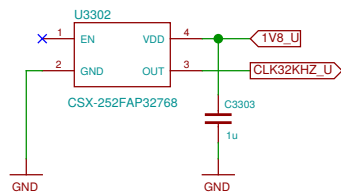

Alternative: OYKTGLJANF-0.032768

Sheet: /Connector to BB-XM/ File: neo900_SS_33.sch		
Title: Connector to BB-XM		
Size: A3	Date: 2016-10-28 21:16:24	Rev:
Plotted by eeshow 96ef3e0+ 20161030-17:20Z		Id: 33/37

TODO: update pin names in footprint

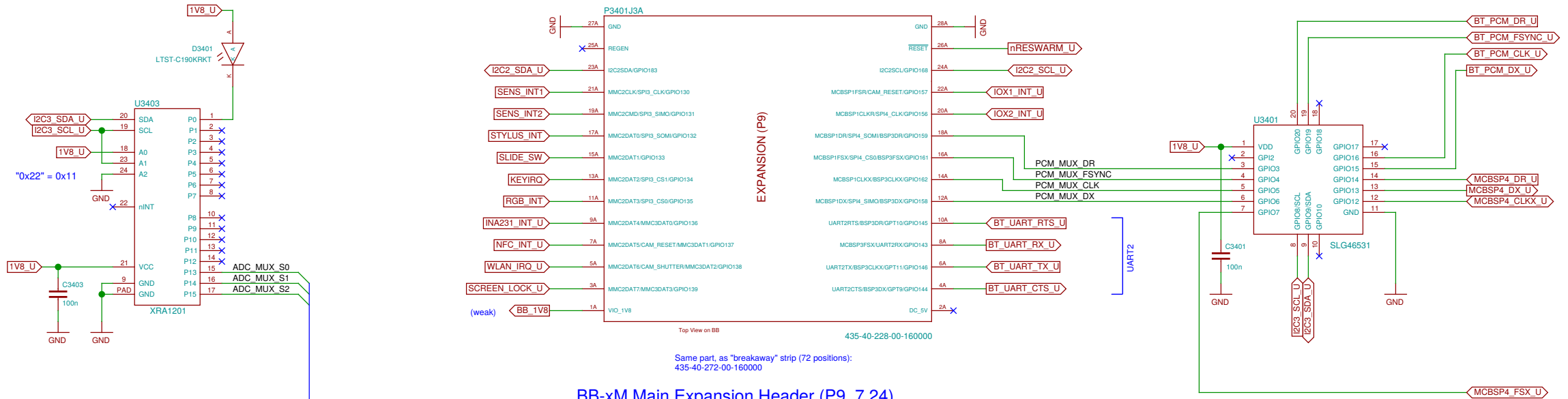

BB-xM Main Expansion Header (P9, 7.24)

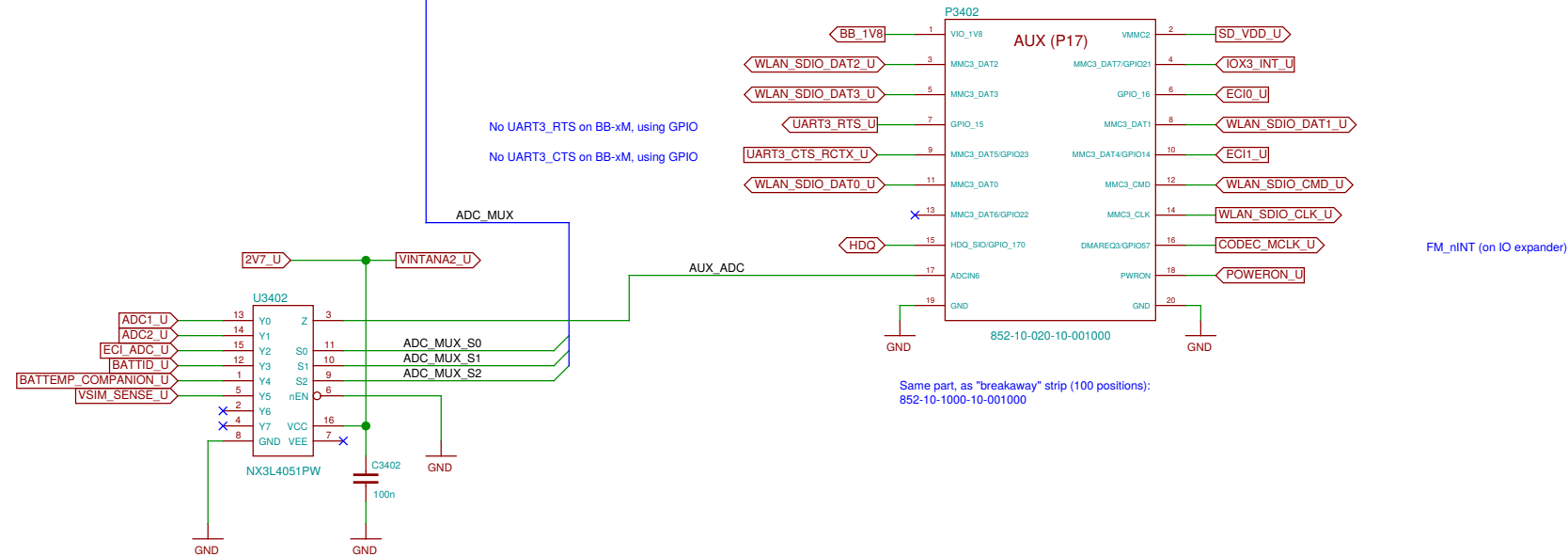

P11 (7.25)



P13 (7.25)

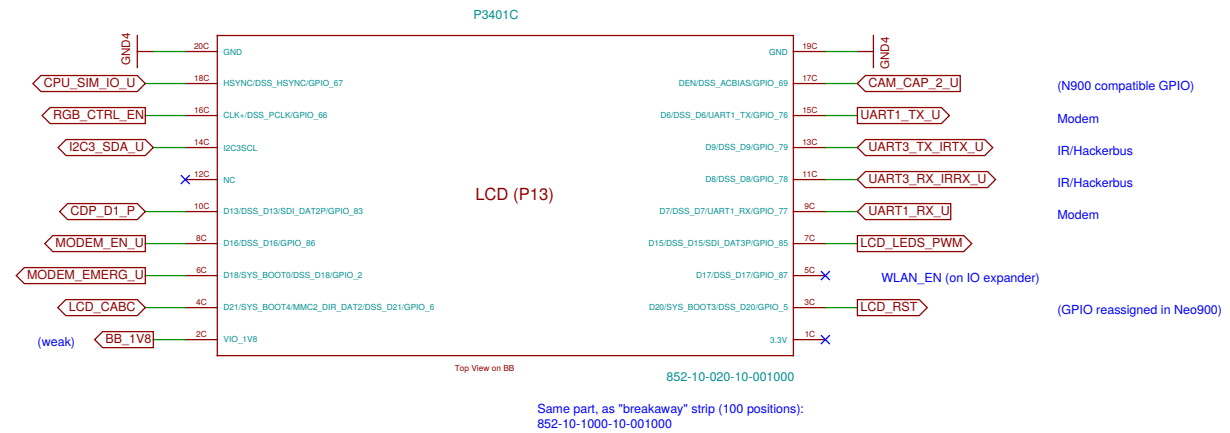

TODO: update pin names in footprint

Sheet: /BB-XM Adapter (DISP)/		
File: neo900_SS_35.sch		
Title: BB-XM Adapter (DISP)		
Size: A3	Date: 2016-10-28 21:16:24	Rev:
Plotted by eeshow 96ef3e0+ 20161030-17:20Z		Id: 35/37

Processor Camera Port Interface (P10, 7.20.3)

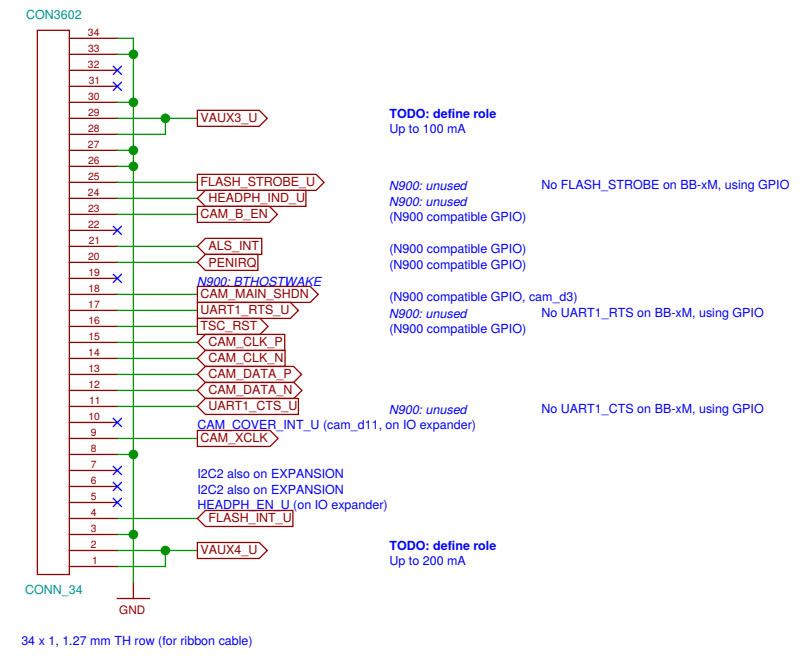
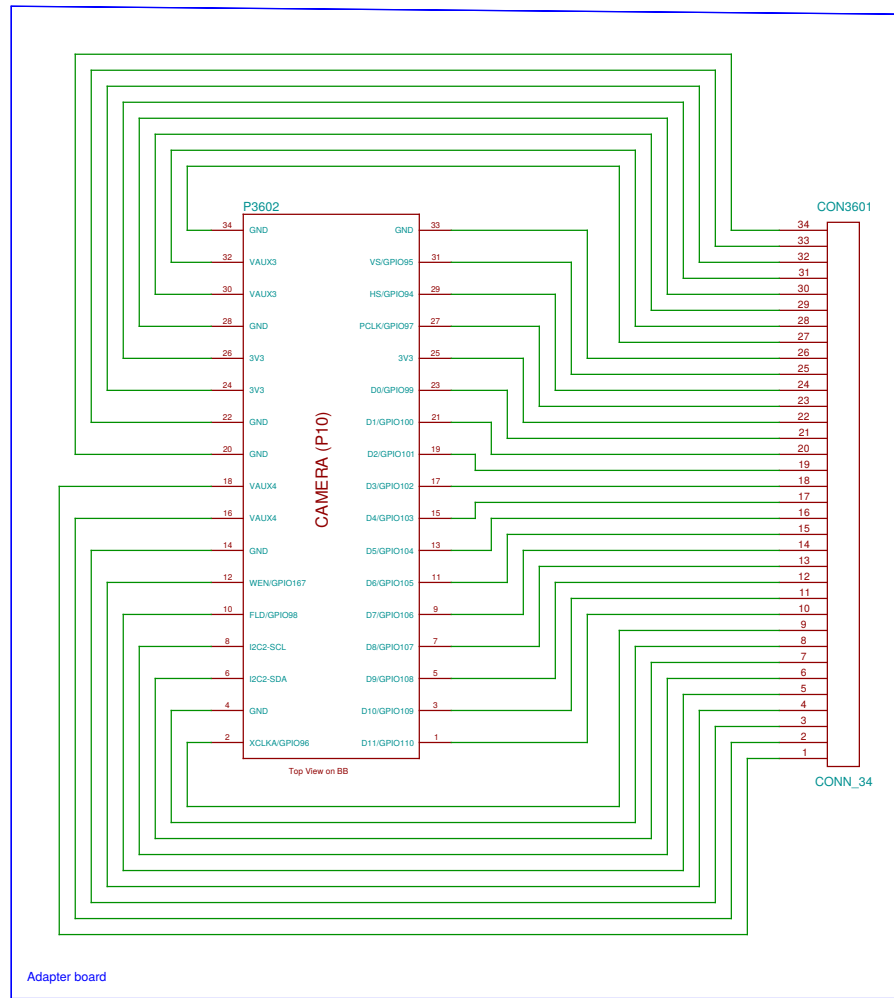

TODO: update pin names in footprint

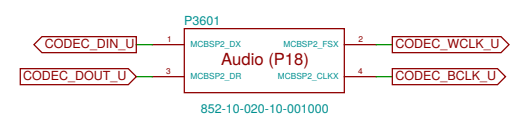

This part is a "breakaway" strip (20 positions) and needs to be customized (cut) before assembly. Alternatively, 852-10-100-10-001000 (100 positions) could be used.

Sheet: /BB-XM Adapter (CAM)/		
File: neo900_SS_36.sch		
Title: BB-XM Adapter (CAM)		
Size: A3	Date: 2016-10-28 21:16:24	Rev:
Plotted by eeshow 96ef3e0+ 20161030-17:20Z		Id: 36/37

Molex Jumper cables to connect BB-XM-Adapter to Uppwer board

N3701 15015-0439	N3702 15015-0439	N3703 15015-0439
CPU	DISP	CAM

N3704 N900 case assembly

N3705 N97-CAMERA-HOLE

N3706 headset jack

N3707 STENCIL-TOP

N3708 STENCIL-BOTTOM

Sheet: /No-Solder Components/ File: neo900_SS_37.sch		
Title: No-Solder Components		
Size: A3	Date: 2016-10-28 21:16:24	Rev:
Plotted by eeshow 96ef3e0+ 20161030-17:20Z		Id: 37/37