

[Click | Here](#)

V

This sheet: [index](#)

Sheet: OTG

File: neo900_SS_2.sch

[OTG & Switches](#)

Sheet: Charger/OTG-Booster

File: neo900_SS_3.sch

[Charger/OTG-Booster](#)

Sheet: Modem Power

File: neo900_SS_4.sch

[Modem Power](#)

Sheet: Fuel Gauge

File: neo900_SS_5.sch

[Fuel Gauge](#)

Sheet: 3G/4G Modem + SIM

File: neo900_SS_6.sch

[3G/4G Modem + SIM](#)

Sheet: Dual SIM switch

File: neo900_SS_7.sch

[Dual SIM switch](#)

Sheet: Antenna connections

File: neo900_SS_8.sch

[Antenna connections](#)

Sheet: WLAN, Bluetooth, FM

File: neo900_SS_9.sch

[WLAN, Bluetooth, FM](#)

Sheet: Sensors

File: neo900_SS_10.sch

[Sensors](#)

Sheet: Audio Codec

File: neo900_SS_11.sch

[Audio Codec](#)

Sheet: Audio Headset + Mic

File: neo900_SS_12.sch

[Audio Headset + Mic](#)

Sheet: ECI

File: neo900_SS_13.sch

[ECI](#)

Sheet: Audio Handsfree

File: neo900_SS_14.sch

[Audio Handsfree](#)

Sheet: Misc

File: neo900_SS_15.sch

[Misc](#)

Sheet: RFID/NFC Reader

File: neo900_SS_16.sch

[RFID/NFC Reader](#)

Sheet: RFID/NFC Controller

File: neo900_SS_17.sch

[RFID/NFC Controller](#)

Sheet: Hackerbus

File: neo900_SS_18.sch

[Hackerbus](#)

Sheet: Infrared

File: neo900_SS_19.sch

[Infrared](#)

Sheet: B2B LOWER-UPPER

File: neo900_SS_20.sch

[B2B LOWER-UPPER](#)

Sheet: uSD Breakout Board

File: neo900_SS_21.sch

[uSD Breakout Board](#)

Sheet: empty

File: neo900_SS_22.sch

[empty](#)

Sheet: Keypad

File: neo900_SS_23.sch

[Keypad](#)

Sheet: Display-Peripherals

File: neo900_SS_24.sch

[Display-Peripherals](#)

Sheet: Display-Panel&Power

File: neo900_SS_25.sch

[Display-Panel&Power](#)

[Click | Here](#)

V

Sheet: CPU + PoP RAM/NAND

File: neo900_SS_26.sch

[CPU + PoP RAM/NAND](#)

Sheet: eMMC

File: neo900_SS_27.sch

[eMMC](#)

Sheet: PMU+Codec

File: neo900_SS_28.sch

[PMU+Codec](#)

Sheet: BB-XM Dummy (TWL4030)

File: neo900_SS_29.sch

[BB-XM Dummy \(TWL4030\)](#)

Sheet: Camera

File: neo900_SS_30.sch

[Camera](#)

Sheet: Fancy LEDs

File: neo900_SS_31.sch

[Fancy LEDs](#)

Sheet: Basic LEDs

File: neo900_SS_32.sch

[Basic LEDs](#)

Sheet: Connector to BB-XM

File: neo900_SS_33.sch

[Connector to BB-XM](#)

Sheet: BB-XM Adapter (CPU)

File: neo900_SS_34.sch

[BB-XM Adapter \(CPU\)](#)

Sheet: BB-XM Adapter (DISP)

File: neo900_SS_35.sch

[BB-XM Adapter \(DISP\)](#)

Sheet: BB-XM Adapter (CAM)

File: neo900_SS_36.sch

[BB-XM Adapter \(CAM\)](#)

Sheet: No-Solder Components

File: neo900_SS_37.sch

[No-Solder Components](#)

Note regarding I2C addresses:
Addresses in the schematics are provided for convenience.
The authoritative source is
<https://neo900.org/git/misc/tree/i2c>

Sheet: /		
File: neo900.sch		
Title: Neo900		
Size: A3	Date: 2016-10-31 08:32:45	Rev:
Plotted by eeshow 01a1b57+ 20161103-02:14Z		Id: 1/37

Lock switch

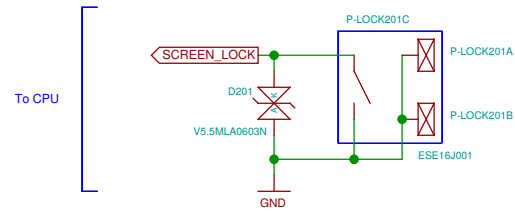

On-off

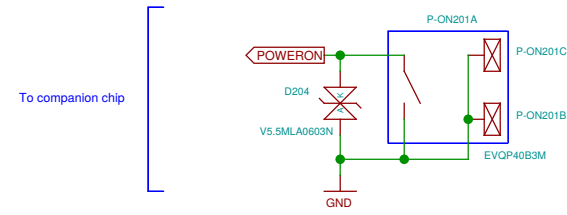

Volume

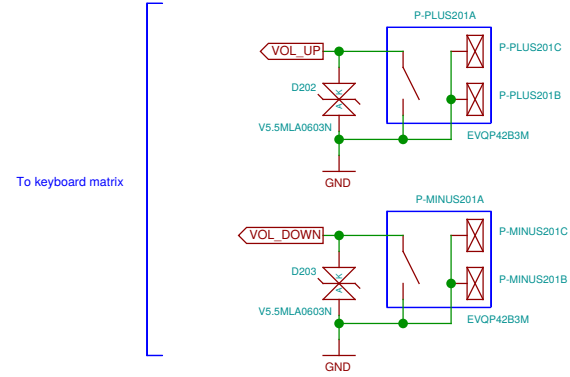

Camera trigger

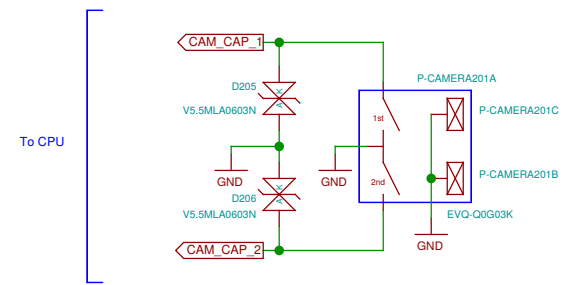

USB OTG connector

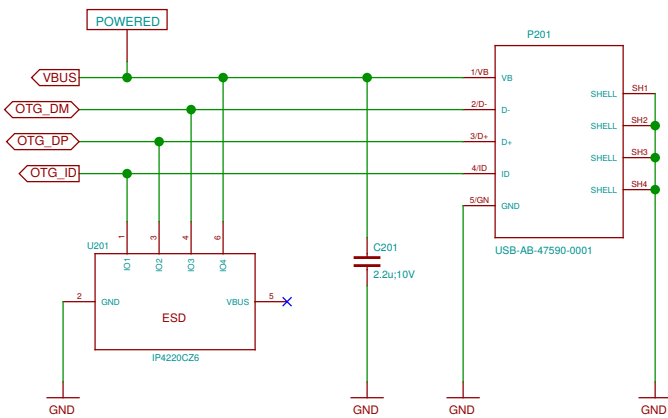

Sheet: ./OTG/		
File: neo900_SS_2.sch		
Title: OTG		
Size: A3	Date: 2016-10-31 08:32:45	Rev:
Plotted by eeshow 01a1b57+ 20161103-02:14Z		Id: 2/37

Battery charger with USB OTG

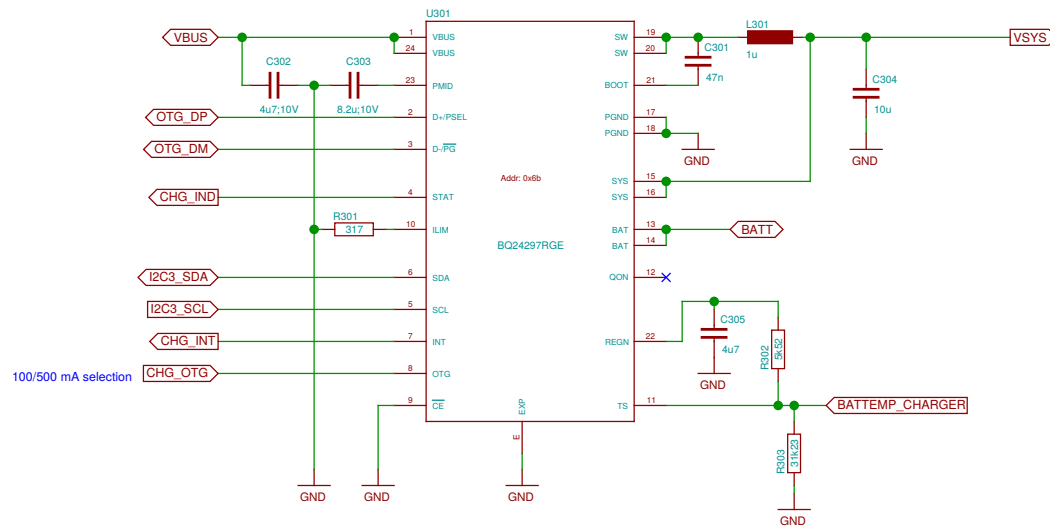

Power distribution and sequencing

Most high-current consumers are on VBAT_SWITCHED.
1V8 signals that the regulators on UPPER are operational.

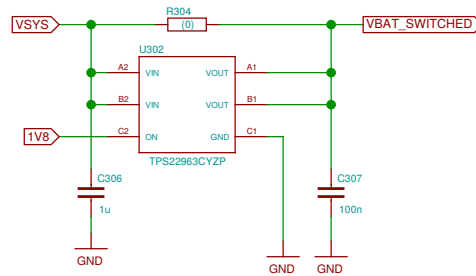

KiCad bureaucracy

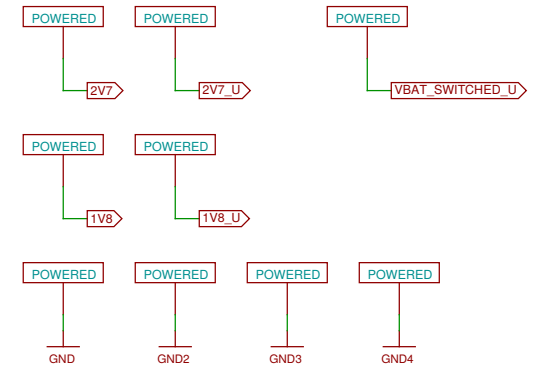

Modem current monitor

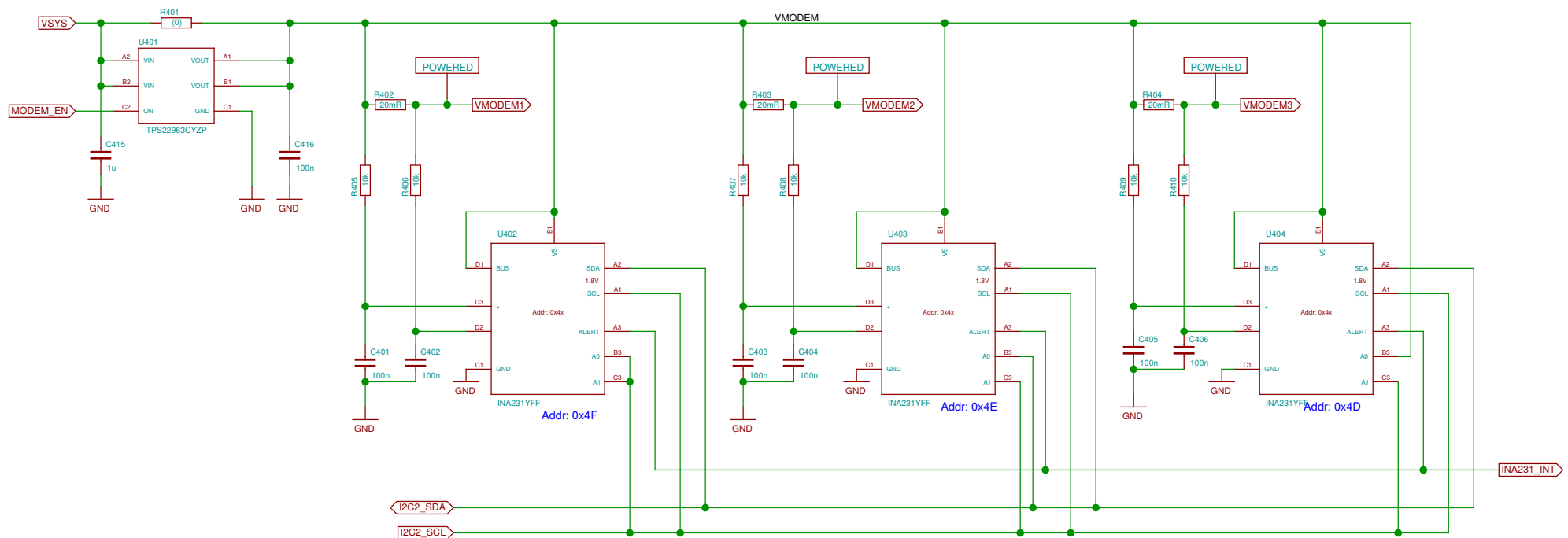

SIM current sensing

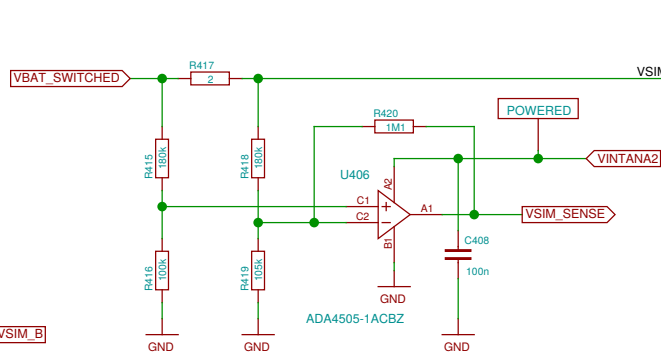

SIM power supply

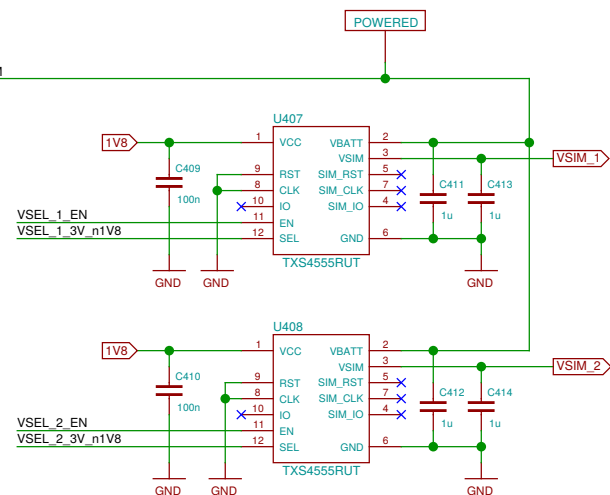

SIM power selection

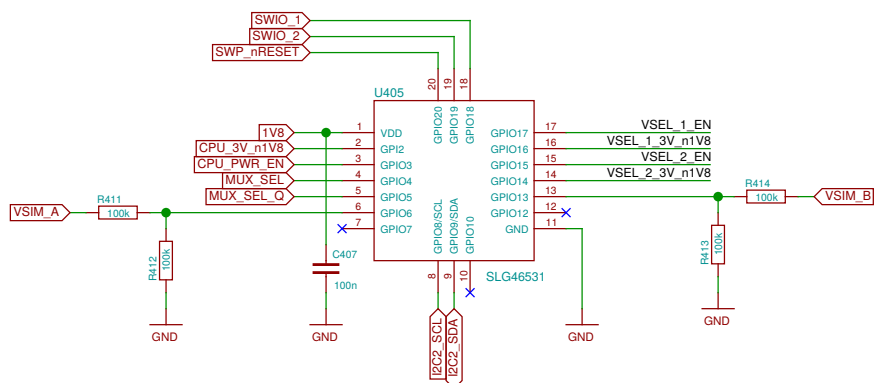

TODO: update SLG design for changed pins

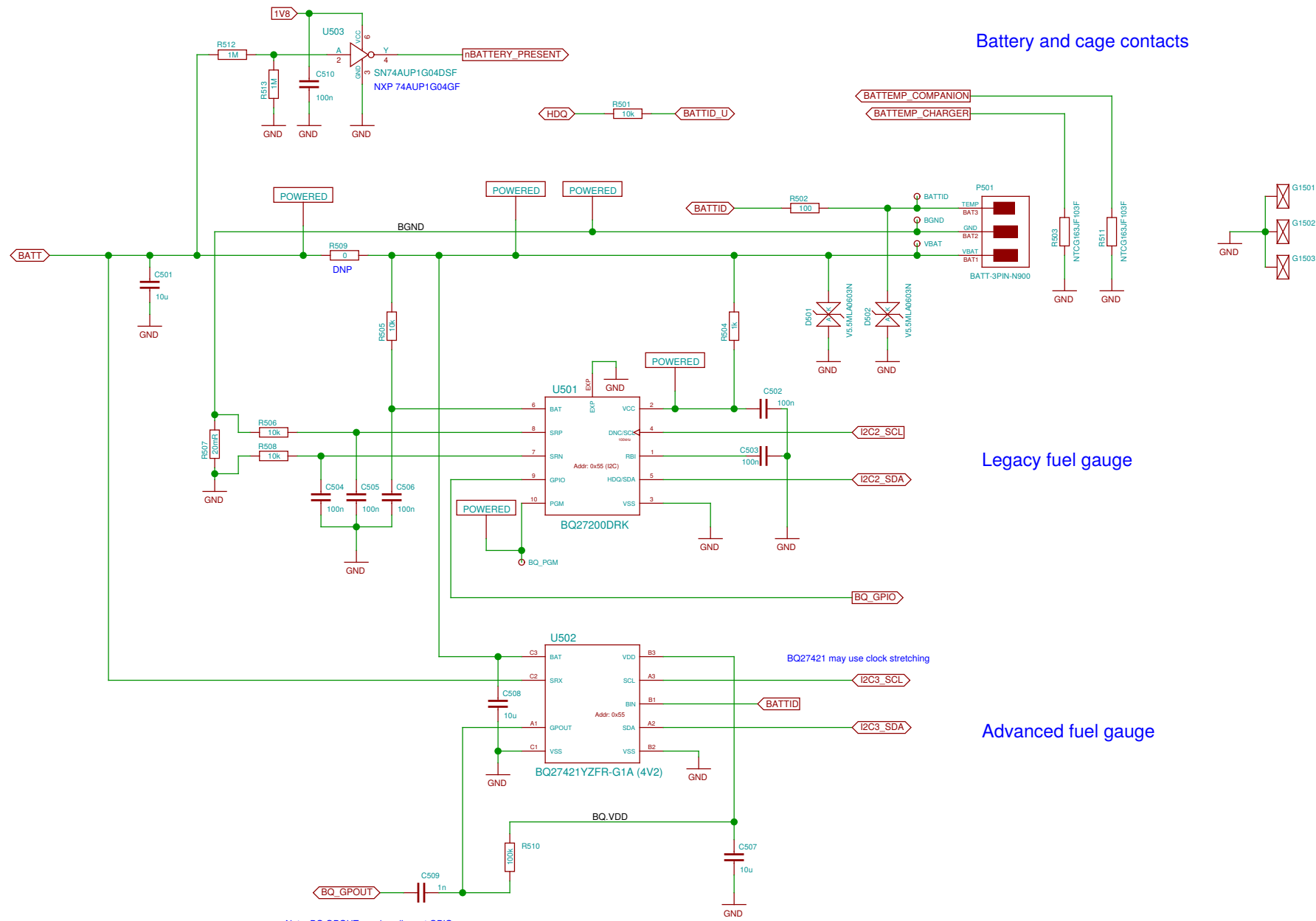

Battery and cage contacts

Legacy fuel gauge

Advanced fuel gauge

Note: BQ.GPOUT needs pull-up at GPIO.

Sheet: /Fuel Gauge/		
File: neo900_SS_5.sch		
Title: Fuel Gauge		
Size: A3	Date: 2016-10-31 08:32:45	Rev:
Plotted by eeshow 01a1b57+ 20161103-02:14Z		Id: 5/37

SIM B bus

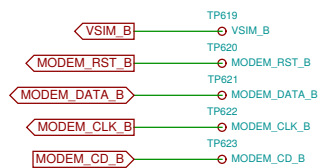

17+10+10 = 37 test points. PCB space permitting, to be in arranged a 6 x 6 + 1 grid with 1.0 mm pitch. This patchfield is to be placed adjacent to the SIM B bus test points.

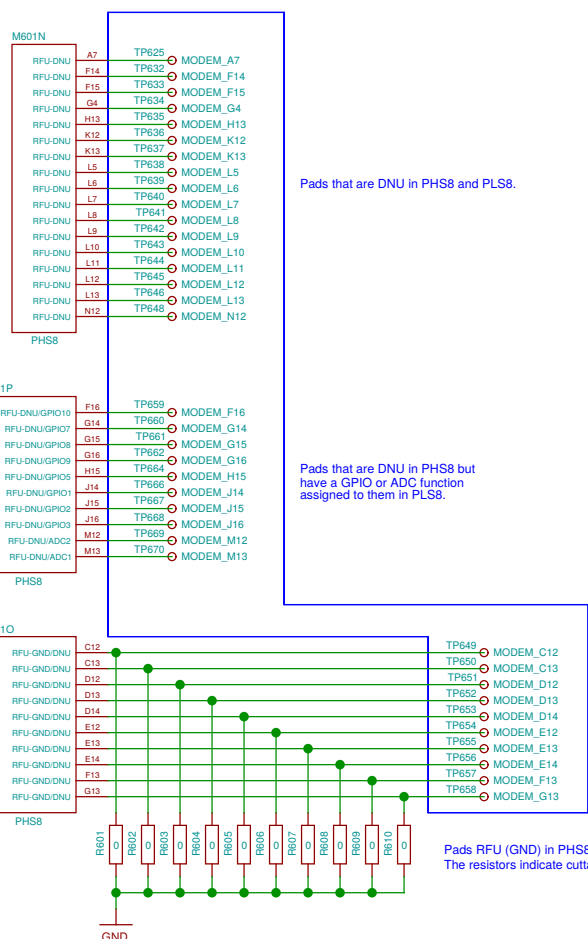

Pads that are DNU in PHS8 and PLS8.

Pads that are DNU in PHS8 but have a GPIO or ADC function assigned to them in PLS8.

Pads RFU (GND) in PHS8 and RFU (DNU) in PLS8. The resistors indicate cuttable traces.

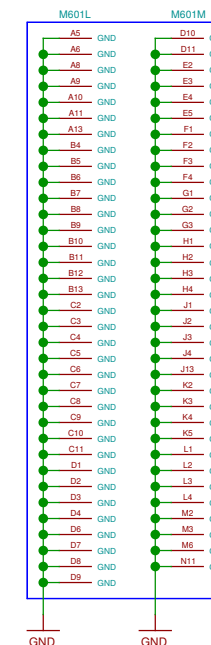
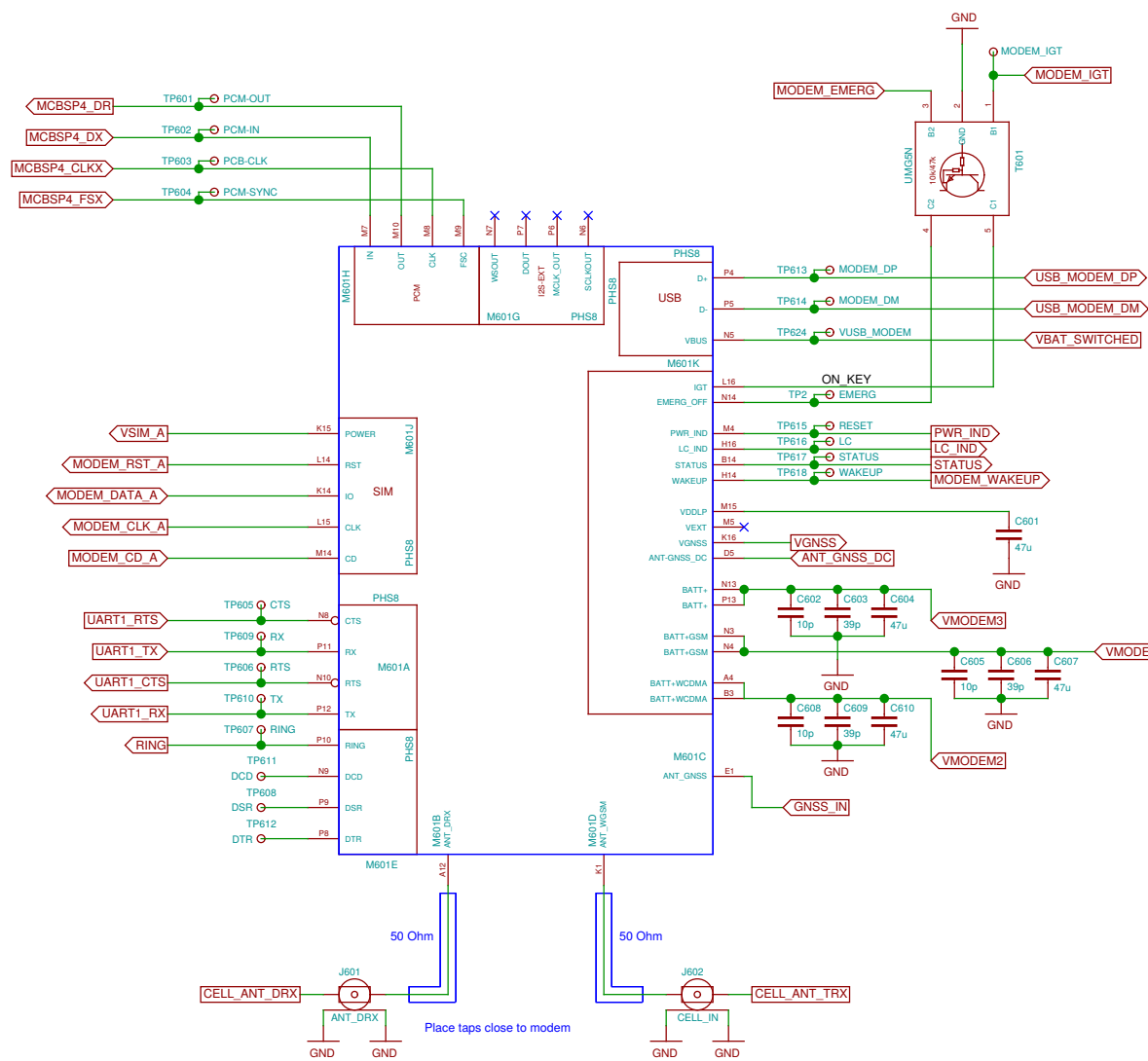

Anti-eavesdropping

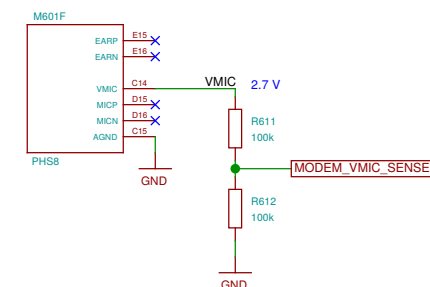

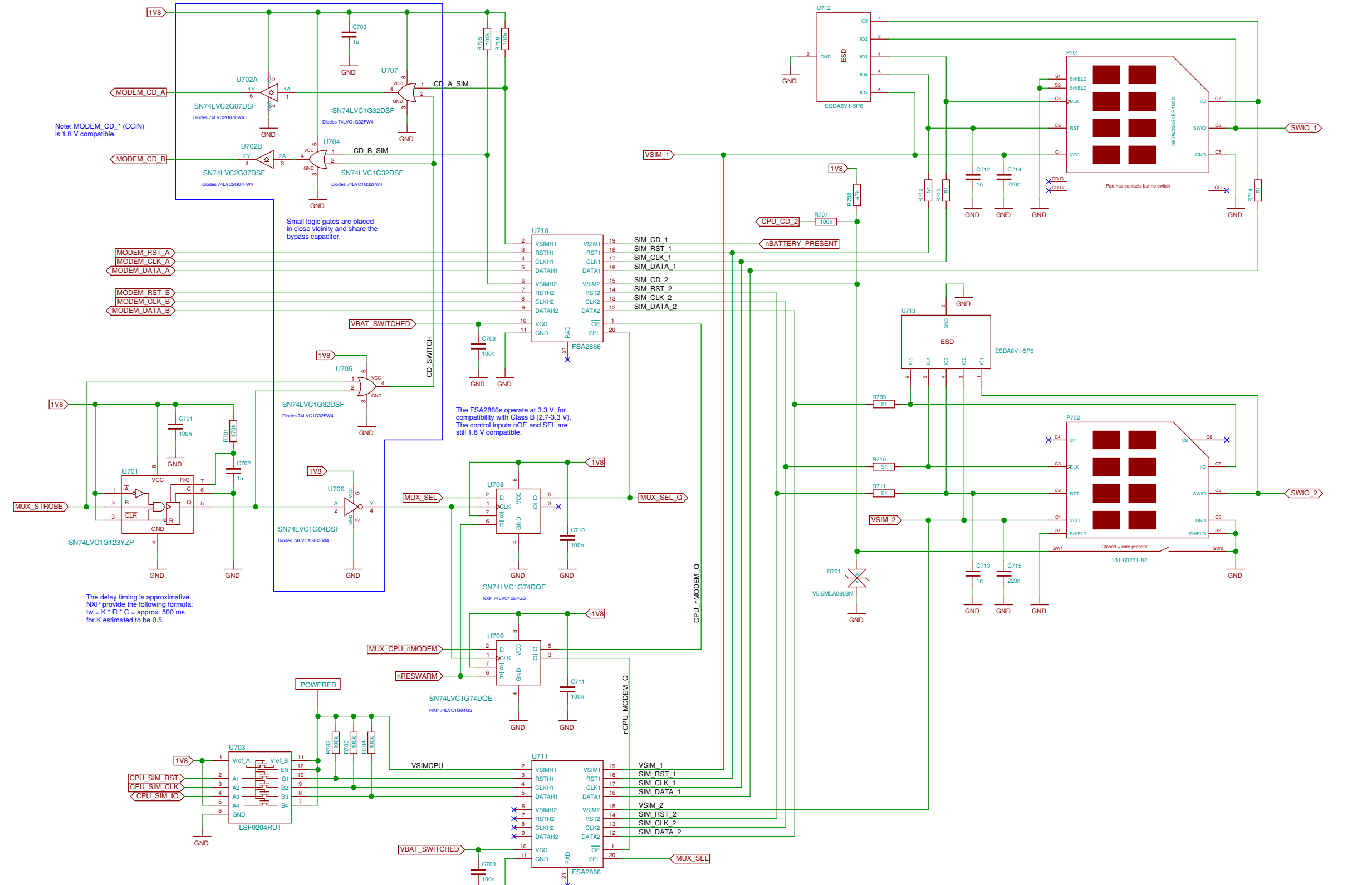

Note: MODEM_CD_* (CCIN) is 1.8 V compatible.

Small logic gates are placed in close vicinity and share the bypass capacitor.

The FSA2866s operate at 3.3 V, for compatibility with Class B (2.7-3.3 V). The control inputs nOE and SEL are still 1.8 V compatible.

The delay timing is approximative. NXP provide the following formula: $t_w = K * R * C = \text{approx. } 500 \text{ ms}$ for K estimated to be 0.5.

Sheet: ./Dual SIM switch/ File: neo900_SS_7.sch		
Title: Dual SIM switch		
Size: A3	Date: 2016-10-31 08:32:45	Rev:
Plotted by eeshow 01a1b57+ 20161103-02:14Z		Id: 7/37

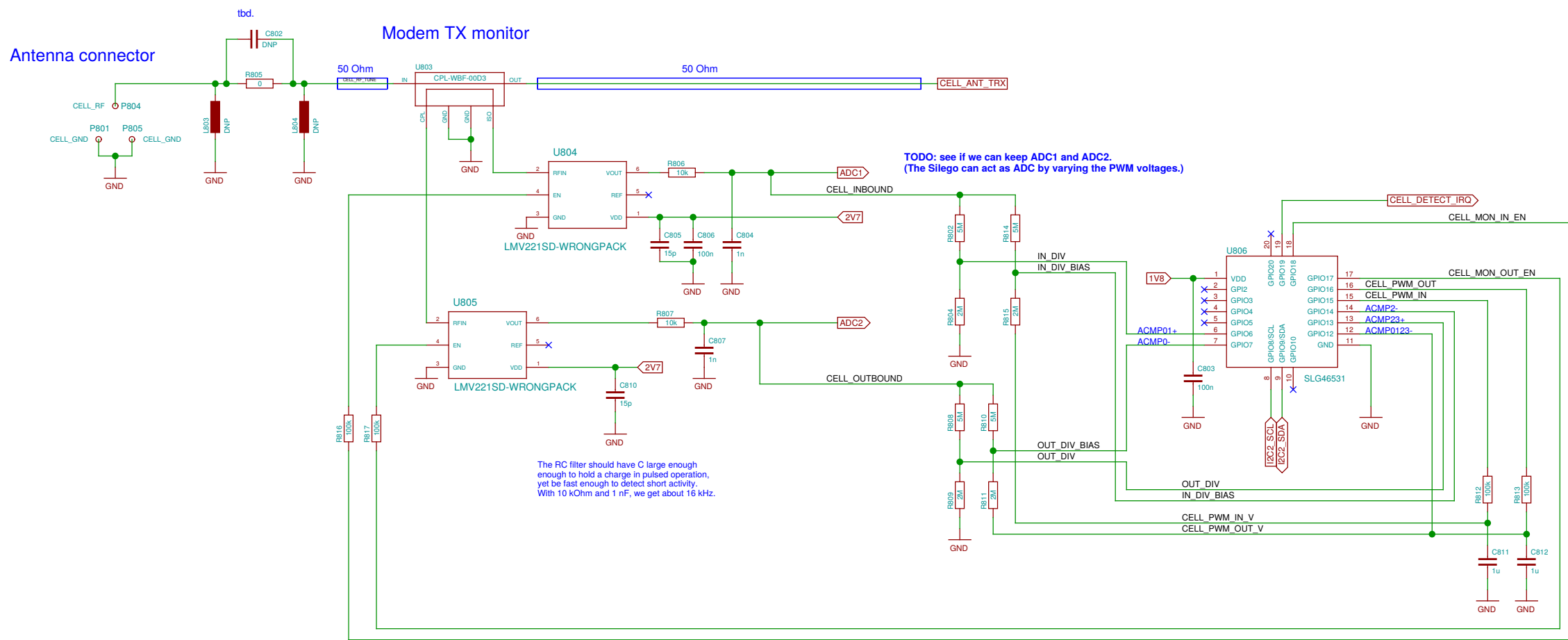
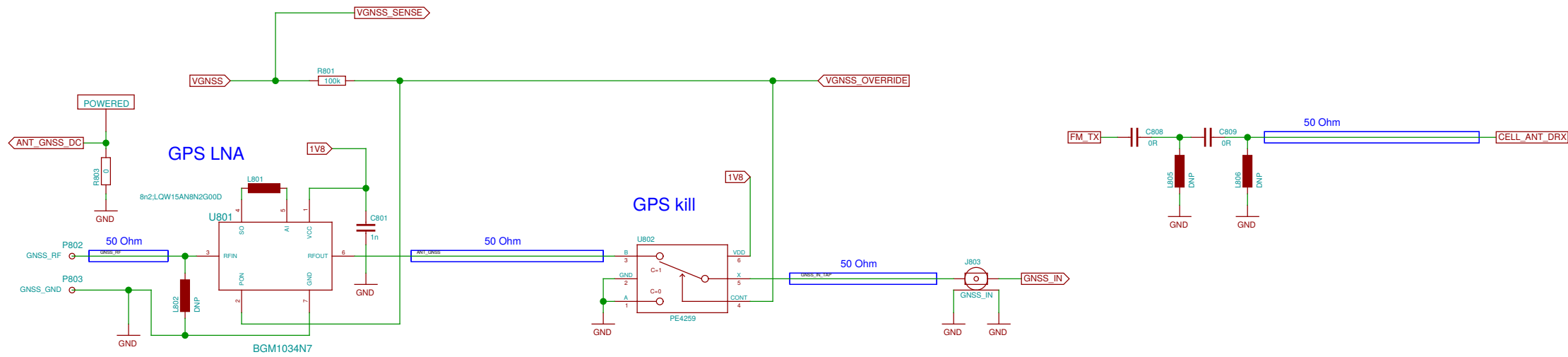

TODO: see if we can keep ADC1 and ADC2.
(The Silego can act as ADC by varying the PWM voltages.)

The RC filter should have C large enough enough to hold a charge in pulsed operation, yet be fast enough to detect short activity. With 10 kOhm and 1 nF, we get about 16 kHz.

Sheet: /Antenna connections/ File: neo900_SS_8.sch		
Title: Antenna connections		
Size: A3	Date: 2016-11-03 17:00:16	Rev:
Plotted by eeshow 01a1b57+ 20161103-02:14Z		Id: 8/37

TODO: assign footprints for c-spring contacts

WLAN/BT antenna

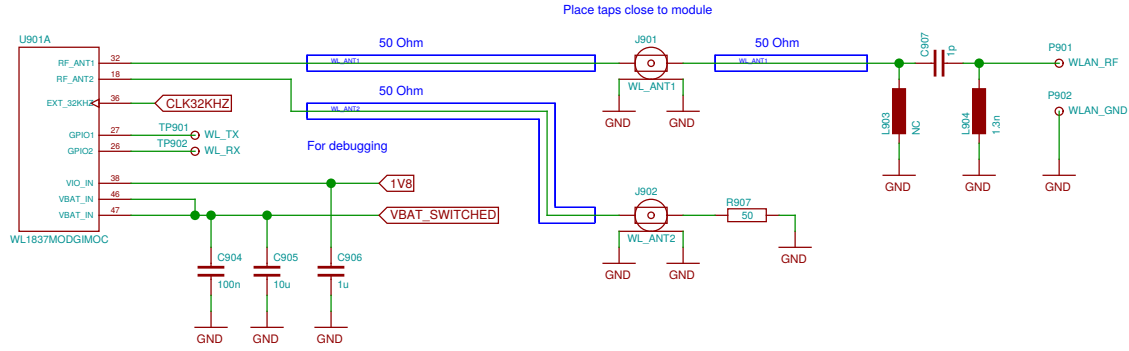

WLAN

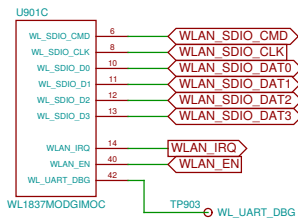

Bluetooth

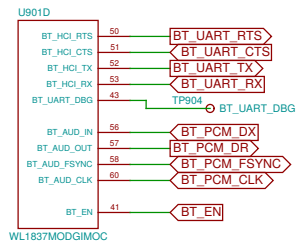

Reserved / Debugging

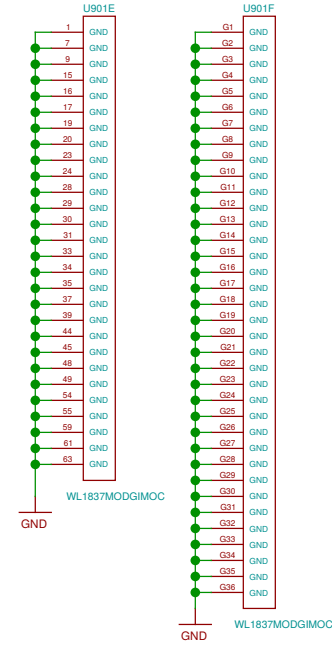
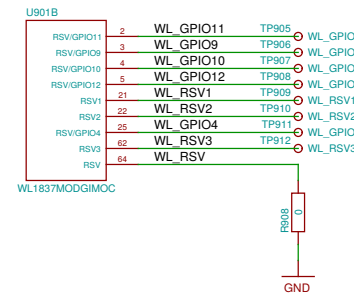

FM Radio (TX/RX)

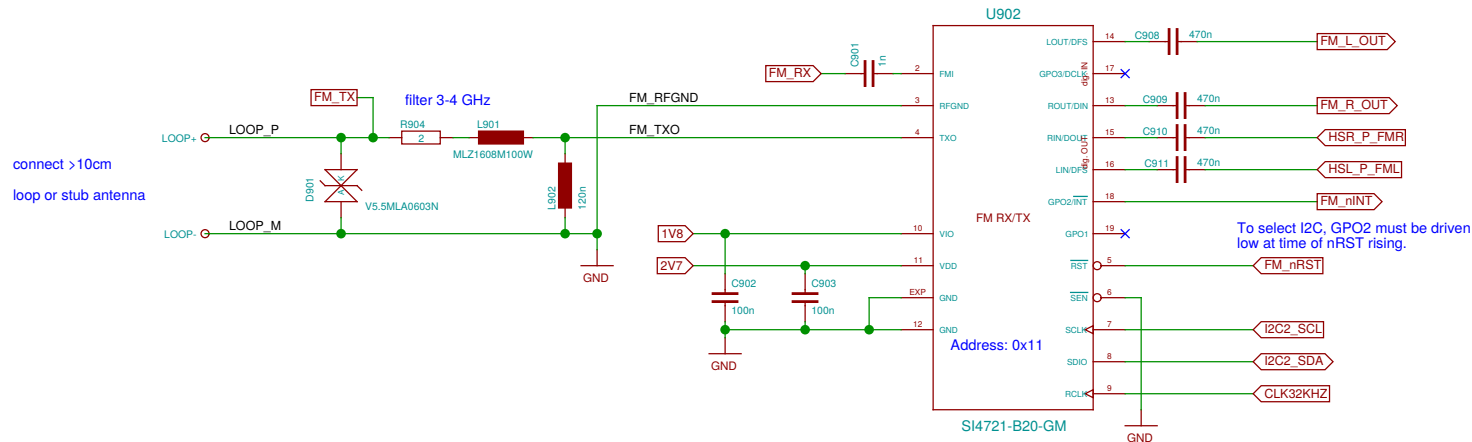

connect >10cm loop or stub antenna

To select I2C, GPO2 must be driven low at time of nRST rising.

SI4705 is pin compatible (mostly) but RX-only

Sheet: /WLAN, Bluetooth, FM/ File: neo900_SS_9.sch	
Title: WLAN, Bluetooth, FM	
Size: A3	Date: 2016-10-31 22:24:58
Plotted by: eeshow 01a1b57+ 20161103-02:14Z	Rev: Id: 9/37

Acceleration (legacy)

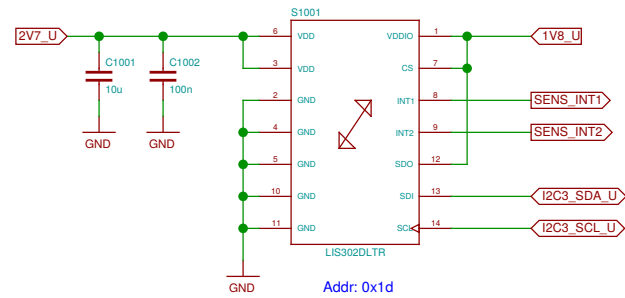

Pressure, humidity

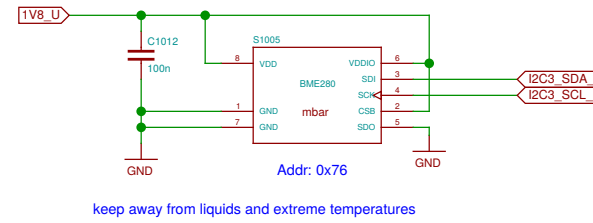

9-axis (acceleration, gyroscope, magnetometer)

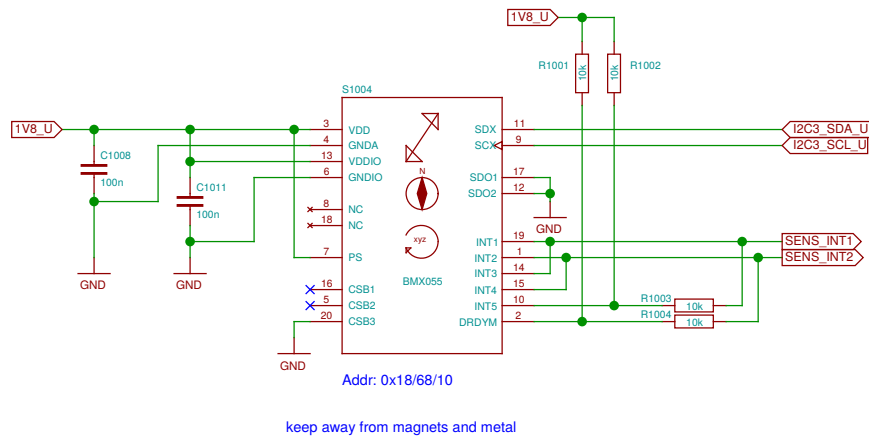

Sheet: ./Sensors/		
File: neo900_SS_10.sch		
Title: Sensors		
Size: A3	Date: 2016-10-31 08:32:45	Rev:
Plotted by eeshow 01a1b57+ 20161103-02:14Z		Id: 10/37

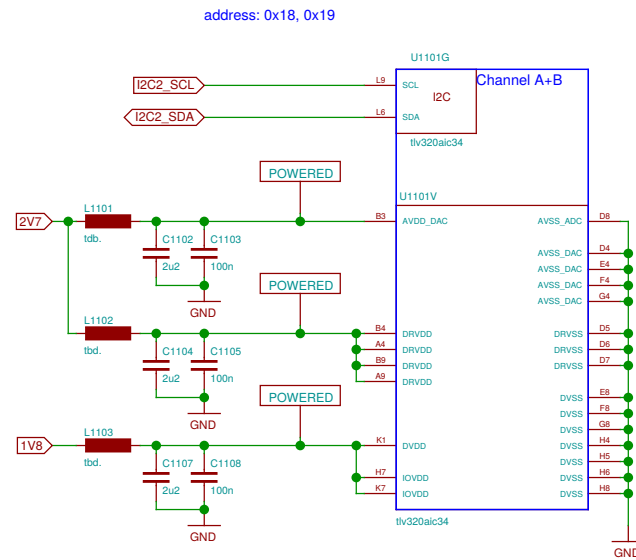
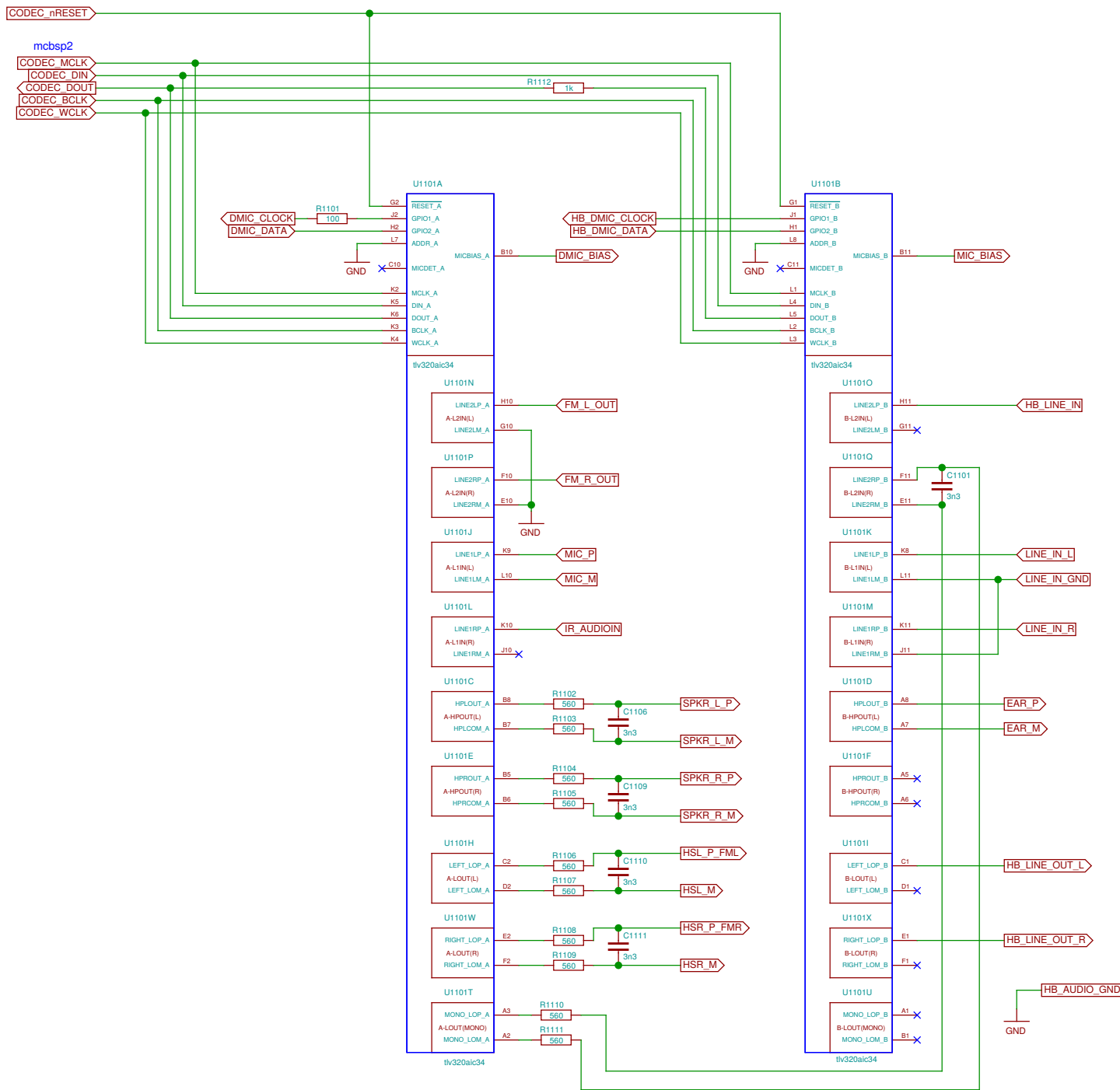

Sheet: /Audio Codec/		
File: neo900_SS_11.sch		
Title: Audio Codec		
Size: A3	Date: 2016-10-31 08:32:45	Rev:
Plotted by eeshow 01a1b57+ 20161103-02:14Z		Id: 11/37

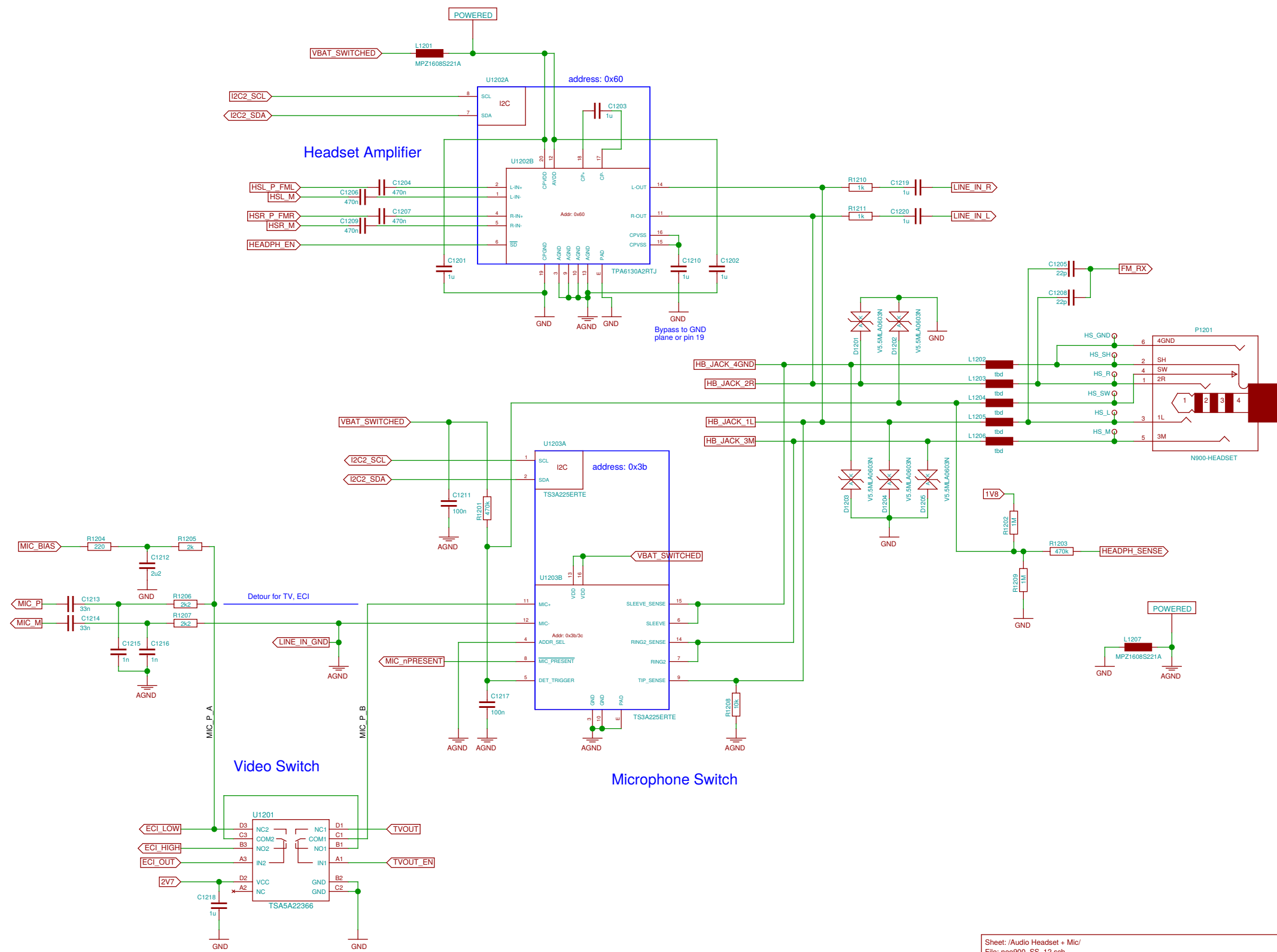

Sheet: /Audio Headset + Mic/	
File: neo900_SS_12.sch	
Title: Audio Headset + Mic	
Size: A3	Date: 2016-10-31 08:32:45
Plotted by eeshow 01a1b57+ 20161103-02:14Z	Rev:
	Id: 12/37

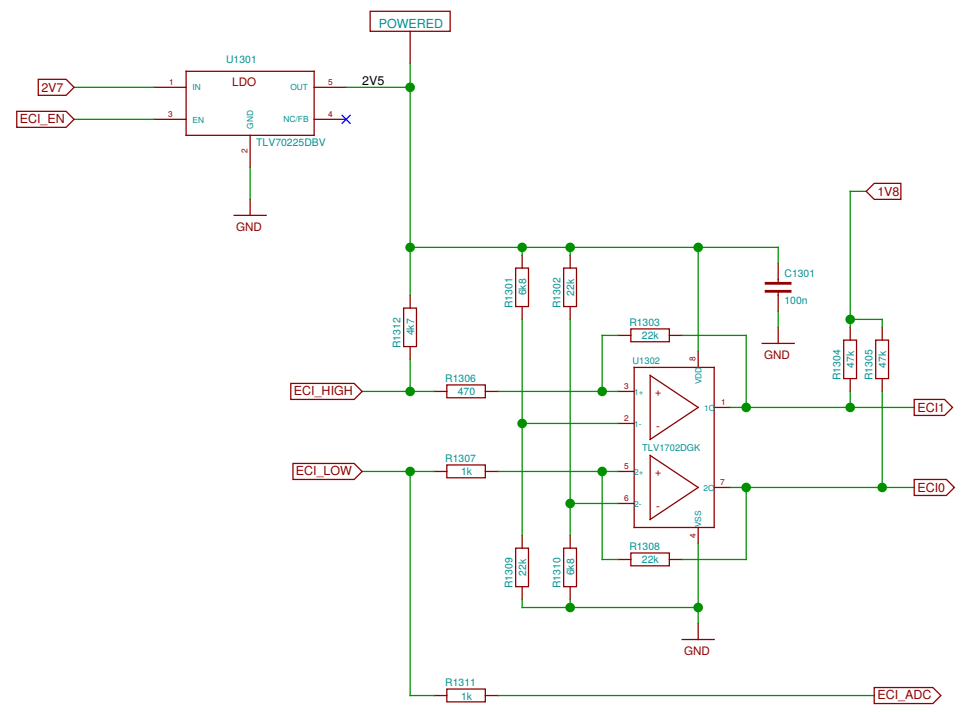

Sheet: /ECI/		
File: neo900_SS_13.sch		
Title: ECI		
Size: A3	Date: 2016-10-31 08:32:45	Rev:
Plotted by eeshow 01a1b57+ 20161103-02:14Z		Id: 13/37

Hands-free

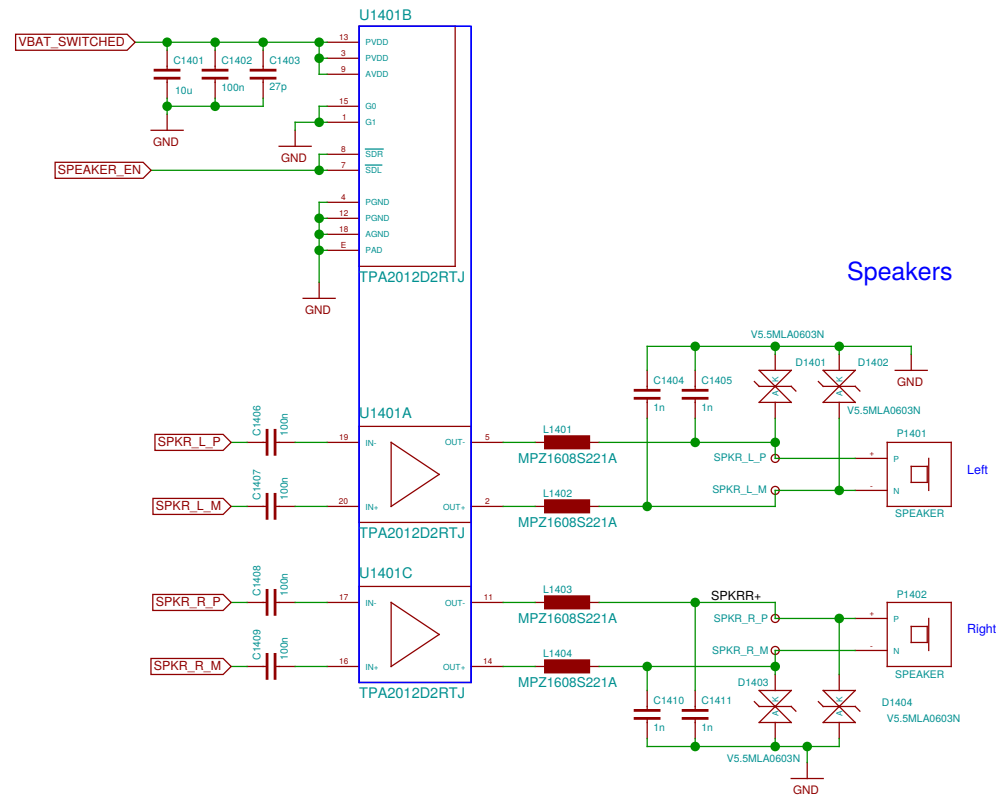

Digital Microphones

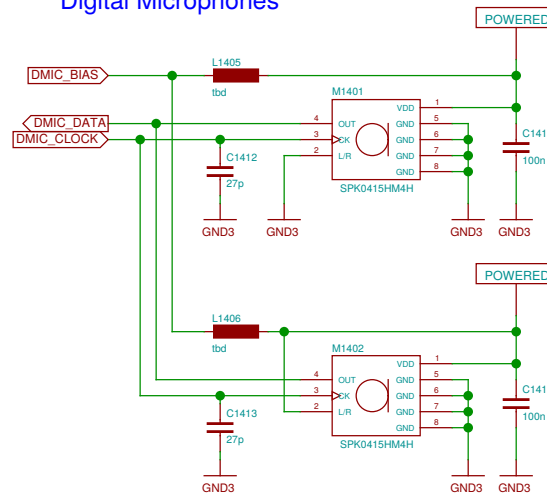

Sheet: /Audio Handsfree/		
File: neo900_SS_14.sch		
Title: Audio Handsfree		
Size: A3	Date: 2016-10-31 08:32:45	Rev:
Plotted by eeshow 01a1b57+ 20161103-02:14Z		Id: 14/37

Shield Contacts on UPPER

For the display

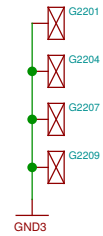

For the key mat

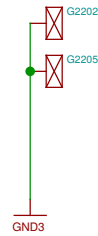

For the "key frame hook"

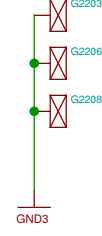

Stylus detect

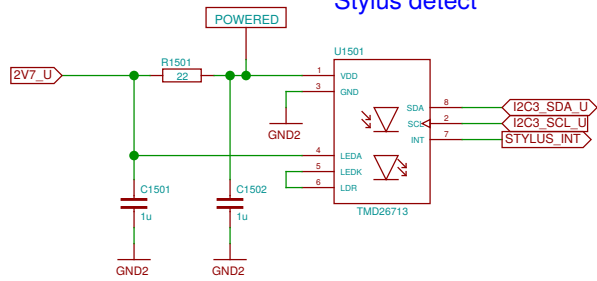

Vibramotor

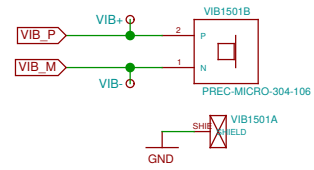

Slide sensor

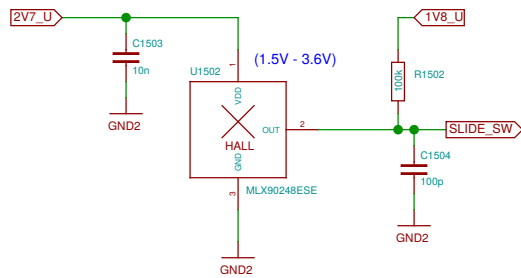

Sheet: /Misc/		
File: neo900_SS_15.sch		
Title: Misc		
Size: A3	Date: 2016-10-31 08:32:45	Rev:
Plotted by eeshow 01a1b57+ 20161103-02:14Z		Id: 15/37

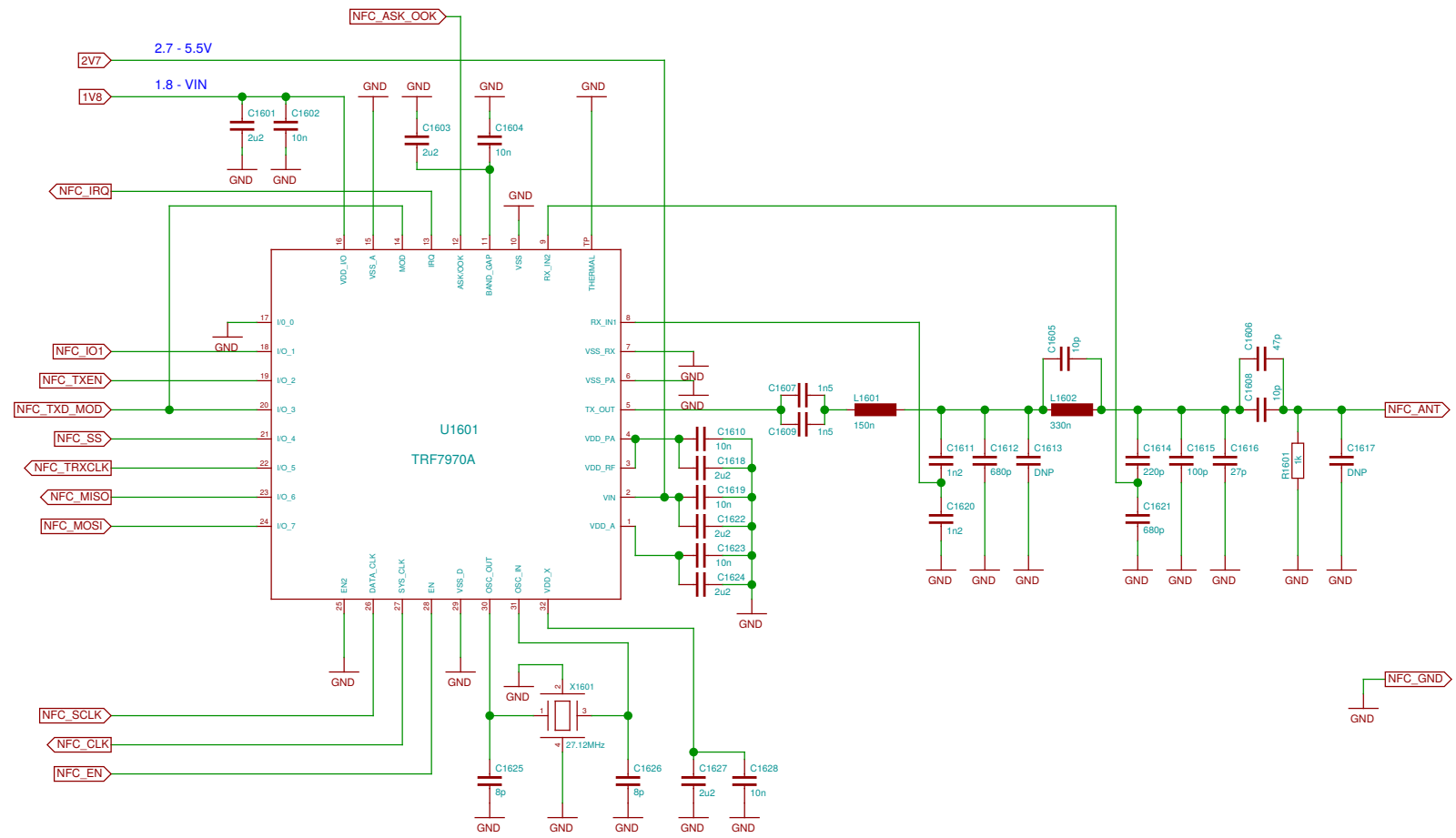

Some choices, 3.2 x 2.6 mm, 8-10 pF:
 NDK NX3225GA-27.12M-STD-CRG-2
 NDK NX3225SA-27.12M-STD-CSR-3
 Taitien XXCCEINANF-27.120000

Sheet: /RFID/NFC Reader/ File: neo900_SS_16.sch		
Title: RFID/NFC Reader		
Size: A3	Date: 2016-10-31 08:32:45	Rev:
Plotted by eeshow 01a1b57+ 20161103-02:14Z		Id: 16/37

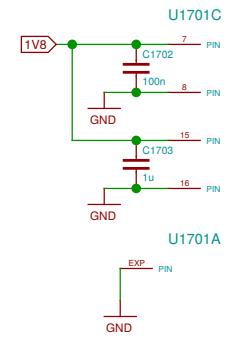
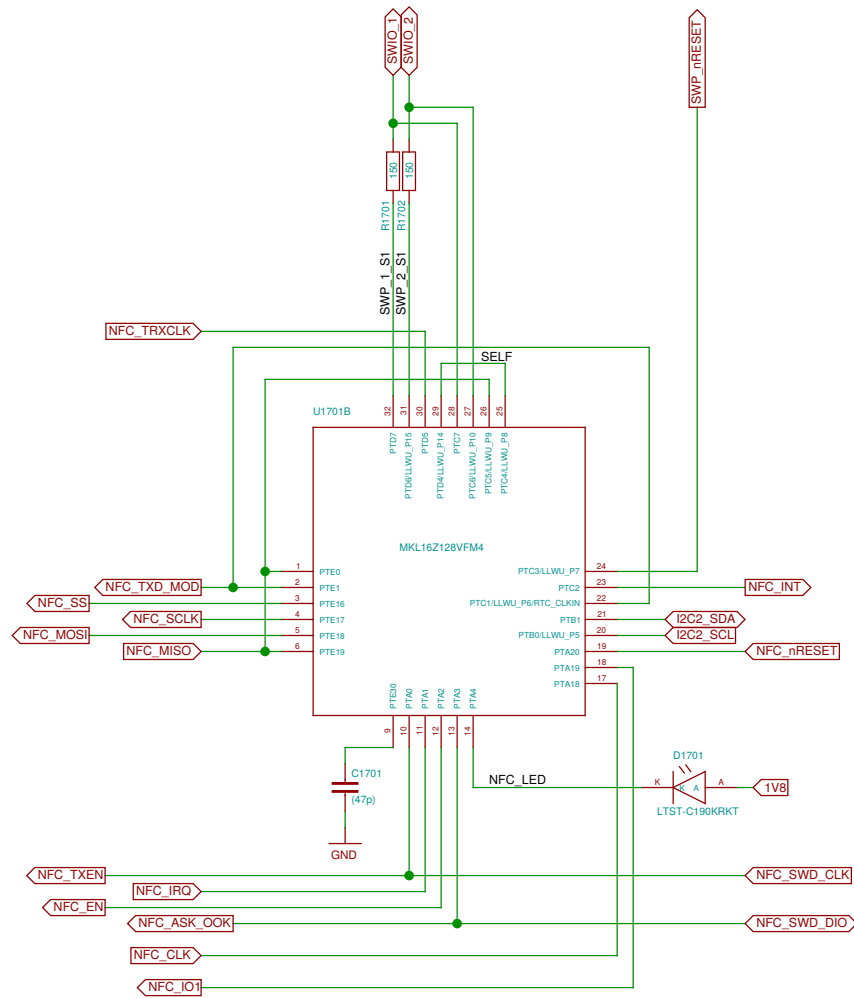

LOWER-BOB Interconnect (LOWER side)

Defined in the Hackerbus specification, <http://neo900.org/stuff/papers/hb.pdf>

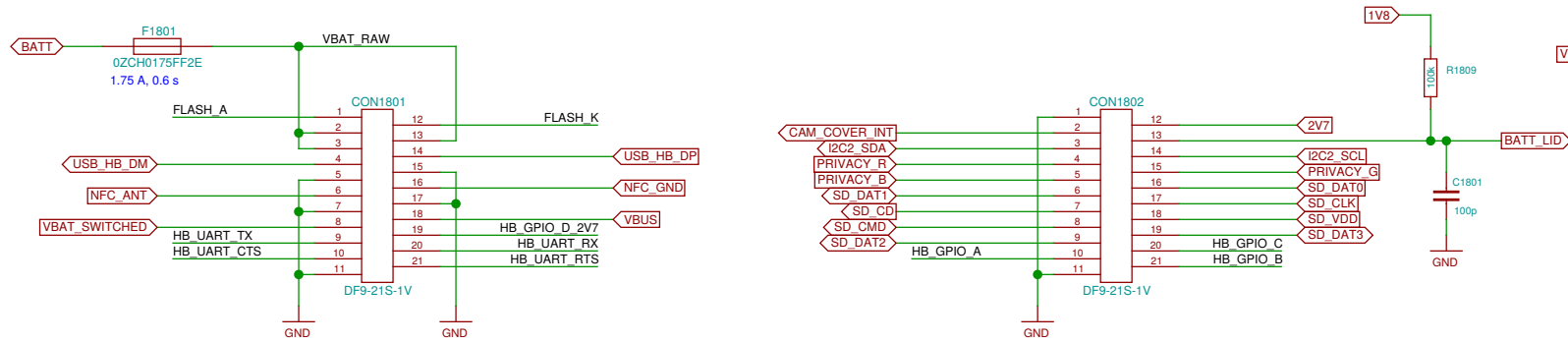

Flash/Torch

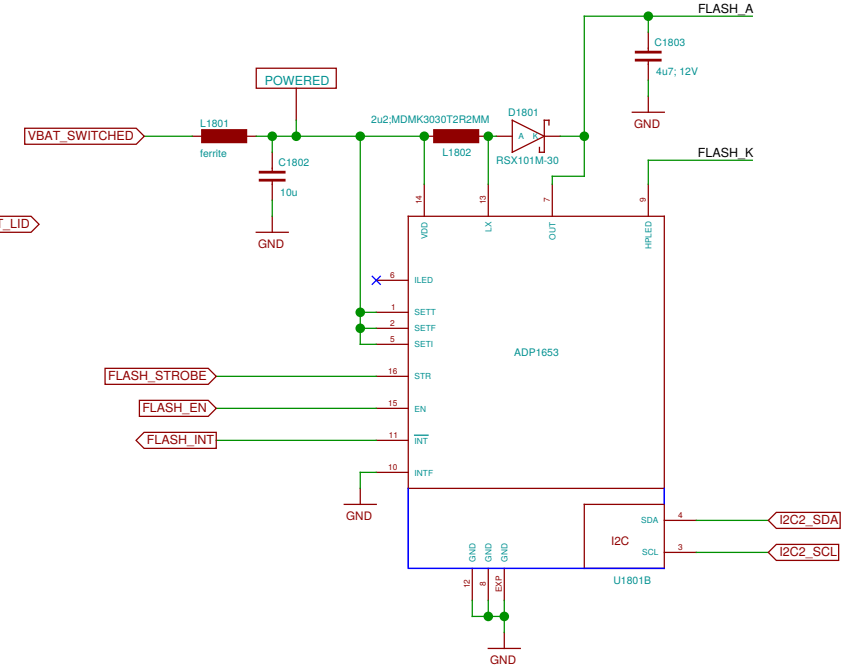

Level shifters for Hackerbus GPIO and UART

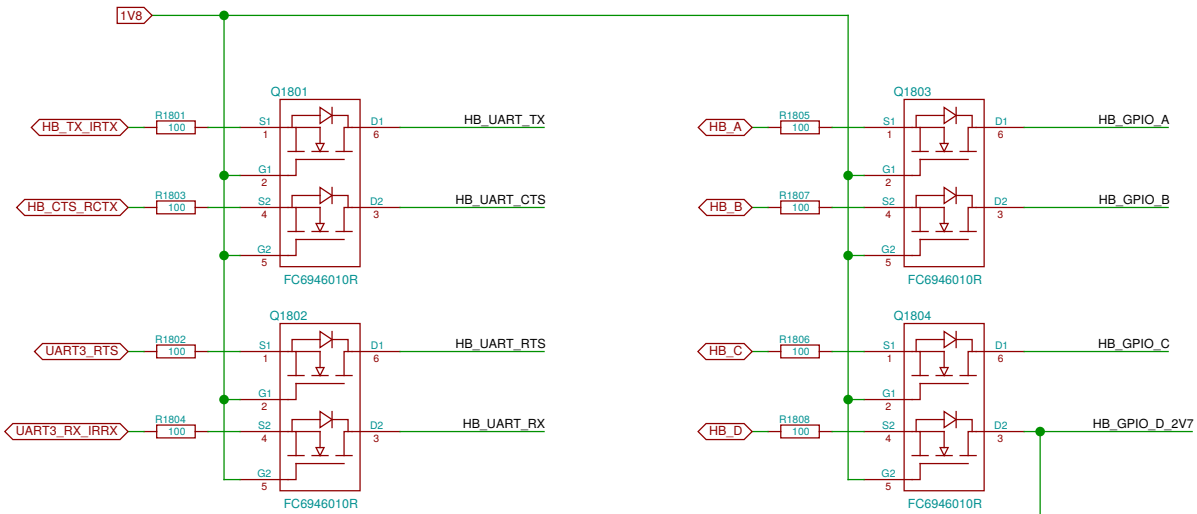

Q18xx alternative: DMN63D8LV by Diodes Inc.

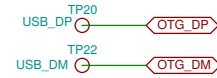
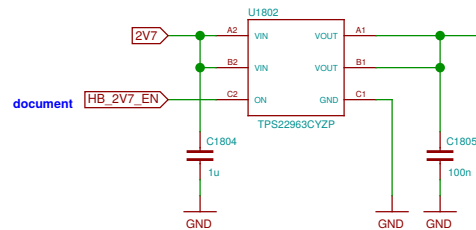

Patchfield

The following signals (or some of them) - **IF FEASIBLE** - should be made available on testpoints next to the 100 Ohm array of R1801 to R1808 for easy yellow wire solder-patching of secondary HB pin functions.

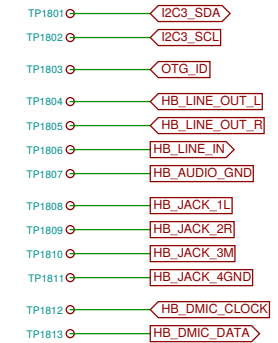

Sheet: /Hackerbus/ File: neo900_SS_18.sch	
Title: Hackerbus	
Size: A3	Date: 2016-10-31 08:32:45
Plotted by: eeshow 01a1b57+ 20161103-02:14Z	Rev: Id: 18/37

TODO: update D1901 footprint

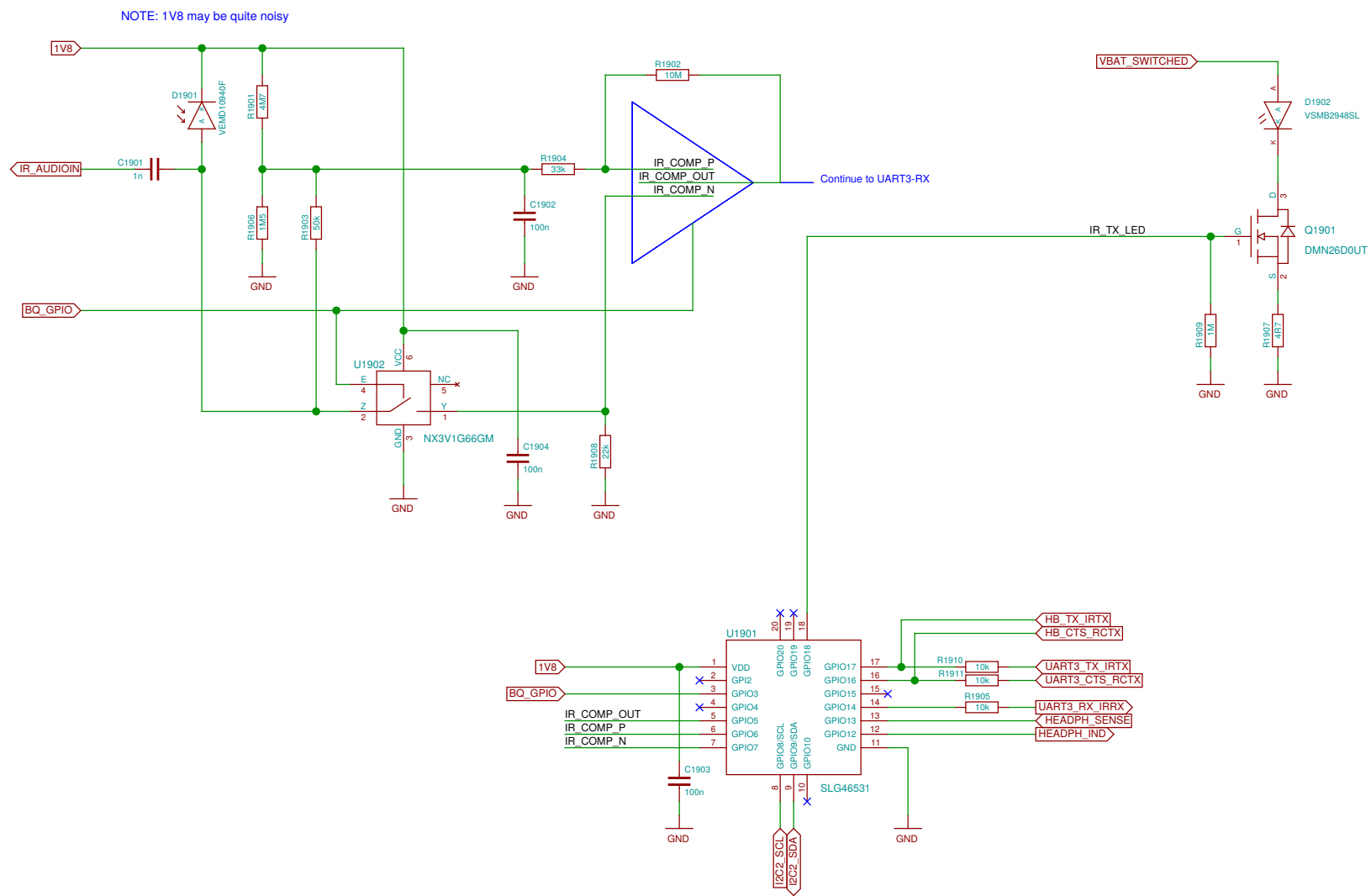

Sheet: /Infrared/		Date: 2016-11-04 21:44:22	
File: neo900_SS_19.sch		Rev:	
Title: Infrared		Id: 19/37	
Size: A3	Plotted by eeshow 01a1b57+ 20161103-02:14Z		

This is just the collection of signals we have. Proper assignment still pending.

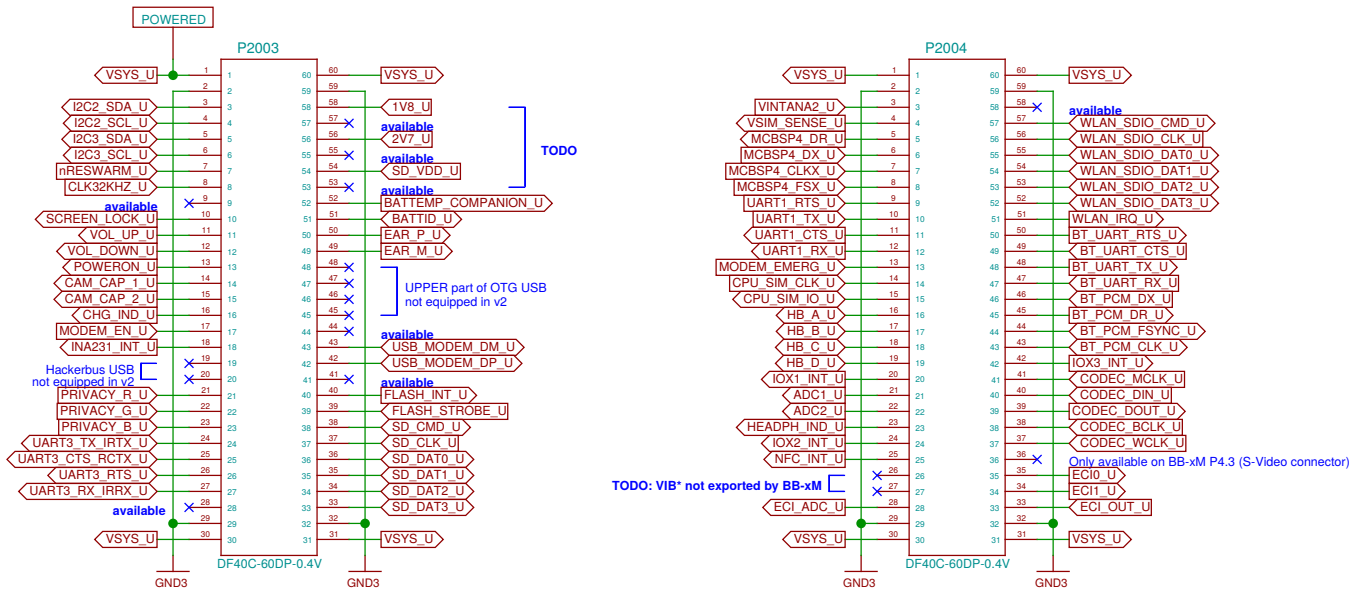

UPPER
LOWER

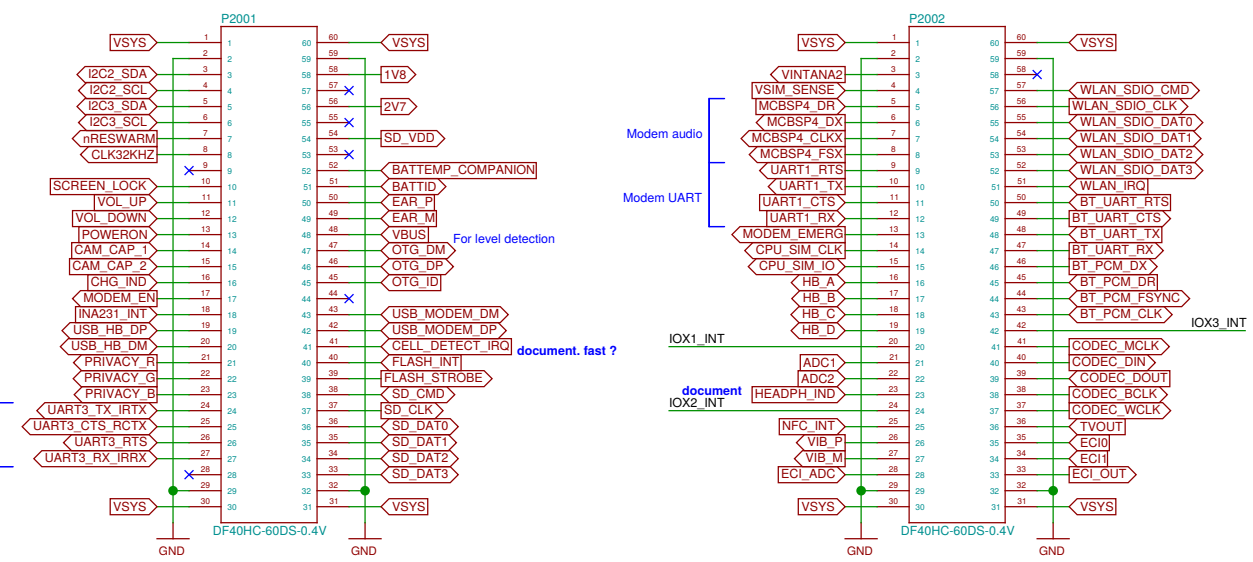
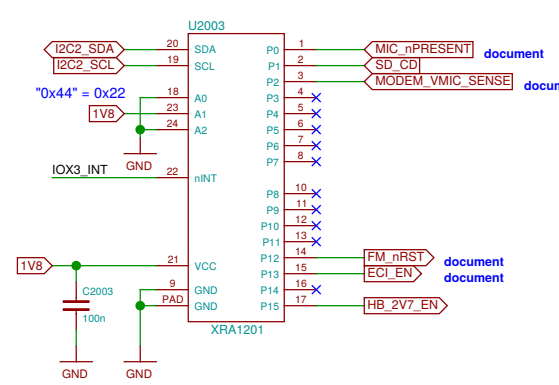
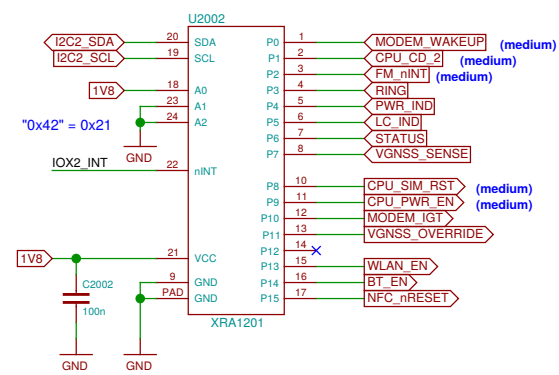
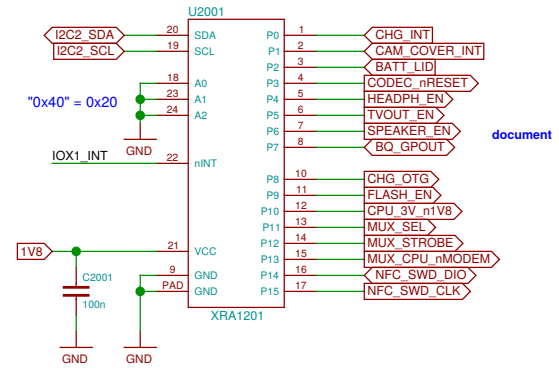

Current rating per contact: 0.3 A

Camera Cover detect

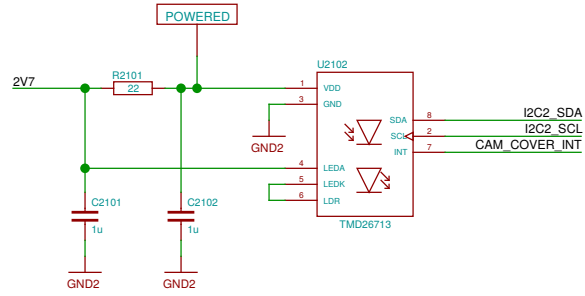

Battery Cover detect

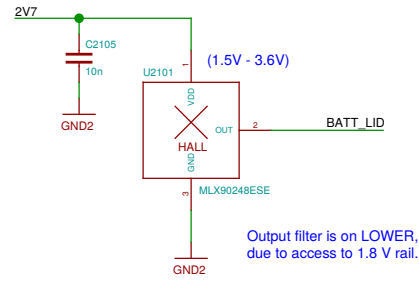

Memory card holder

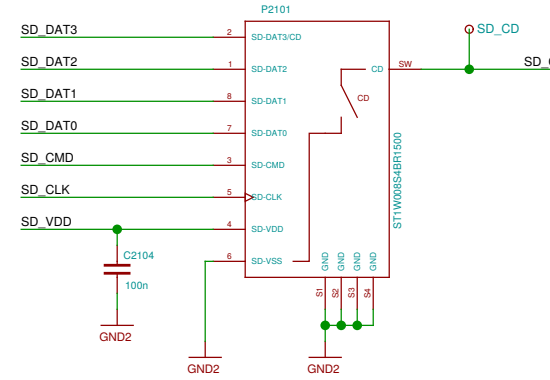

Camera flash

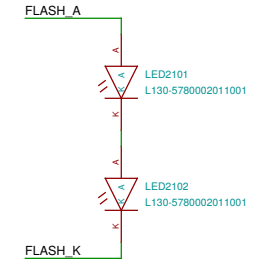

Privacy LED

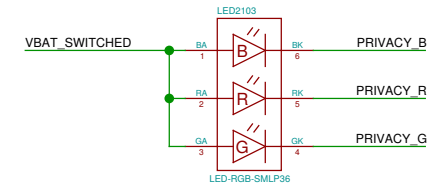

LOWER-BOB Interconnect (BOB side)

Defined in the Hackerbus specification, <http://neo900.org/stuff/papers/hb.pdf>

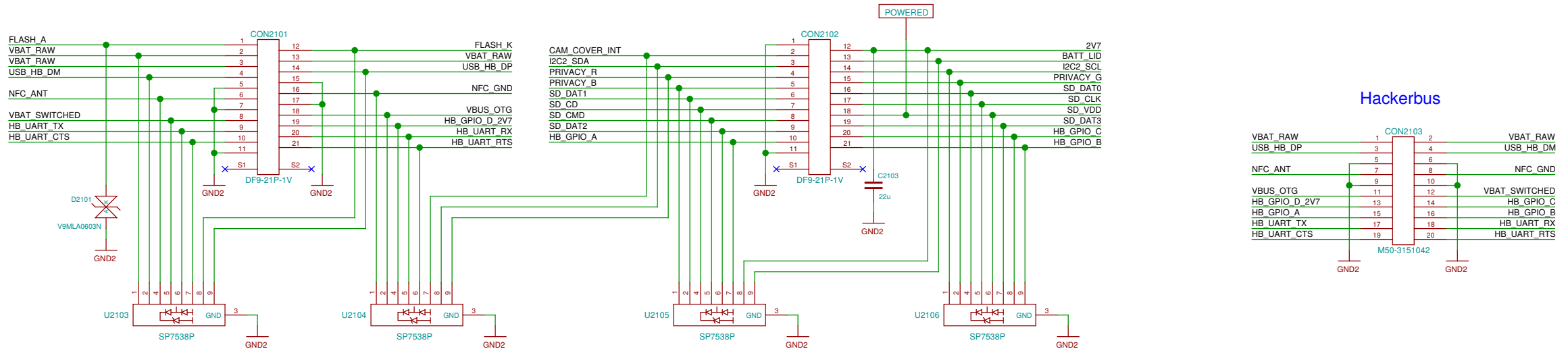

ESD pin assignment is only indicative.
Actual assignment to be defined by layout.

Sheet: /uSD Breakout Board/ File: neo900_SS_21.sch		
Title: uSD Breakout Board		
Size: A3	Date: 2016-11-05 03:52:42	Rev:
Plotted by eeshow 01a1b57+ 20161103-02:14Z		Id: 21/37

TODO: consider sheet for deletion

Sheet: /empty/		
File: neo900_SS_22.sch		
Title: empty		
Size: A3	Date: 2016-10-31 08:32:45	Rev:
Plotted by eeshow 01a1b57+ 20161103-02:14Z		Id: 22/37

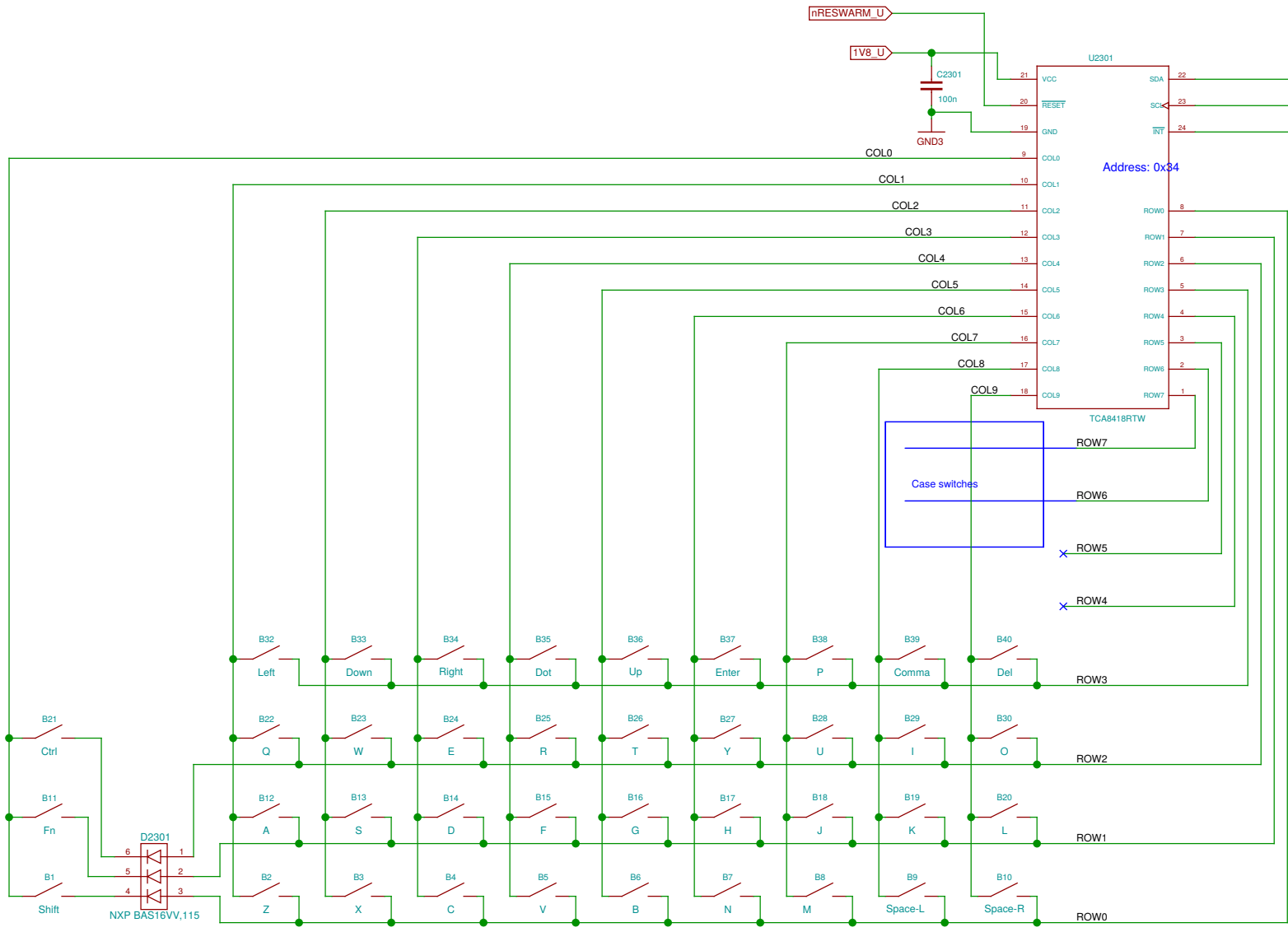

Alternative: Diodes Inc. BAS16VV-7
 Warning: Diodes Inc. have cathodes on pin 1 side, NXP anodes !

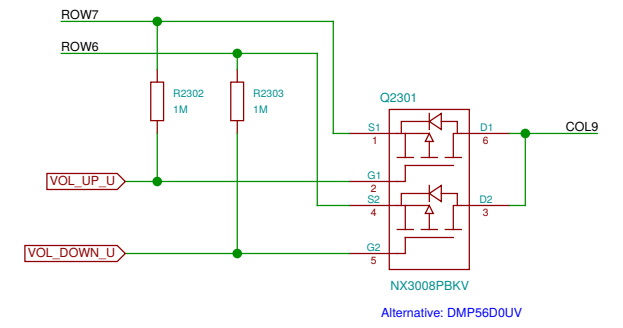

Sheet: /Keypad/		
File: neo900_SS_23.sch		
Title: Keypad		
Size: A3	Date: 2016-10-31 08:32:45	Rev:
Plotted by eeshow 01a1b57+ 20161103-02:14Z		Id: 23/37

Resistive Touch (display connector)

Touch screen controller

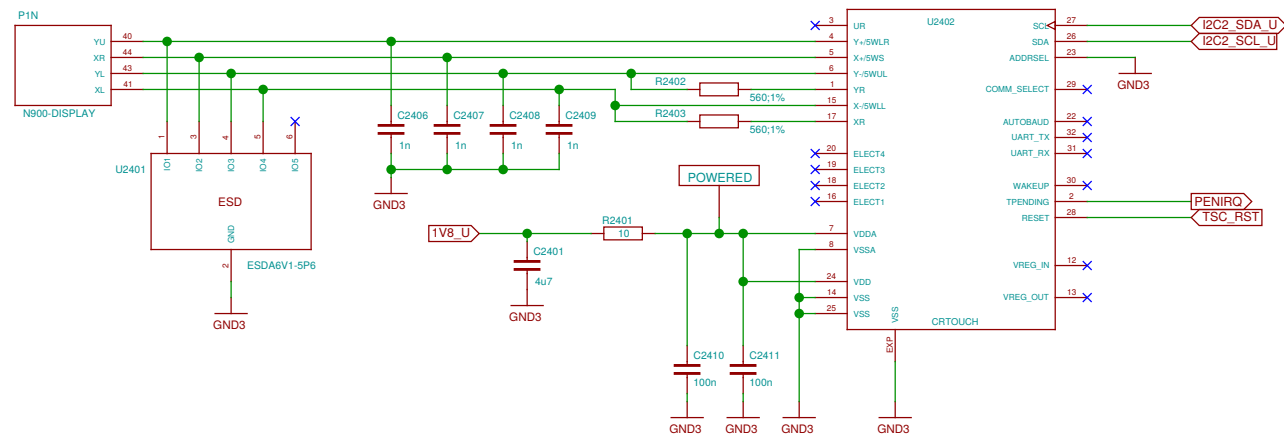

Sheet: ./Display-Peripherals/ File: neo900_SS_24.sch		
Title: Display-Peripherals		
Size: A3	Date: 2016-10-31 08:32:45	Rev:
Plotted by eeshow 01a1b57+ 20161103-02:14Z		Id: 24/37

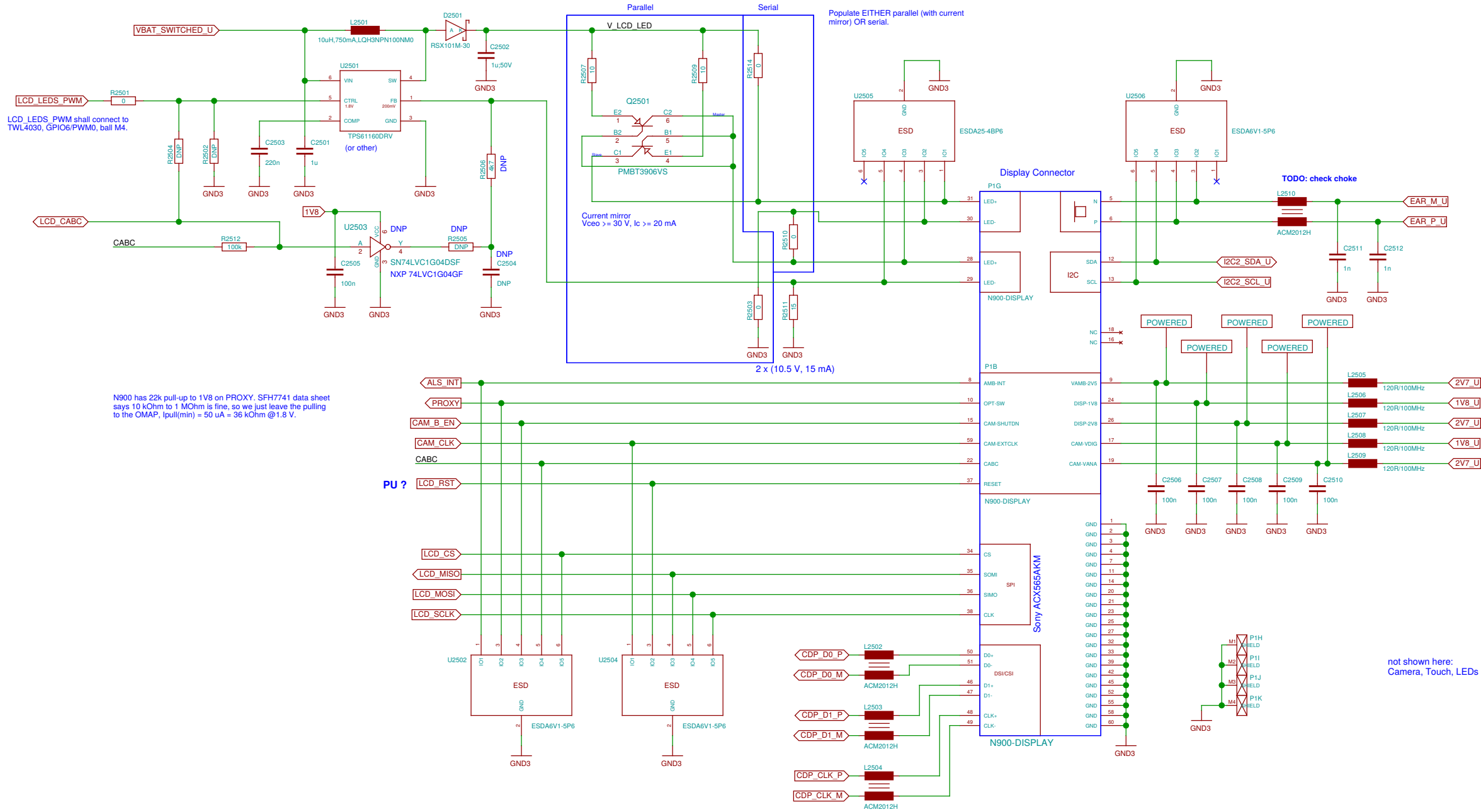

LCD_LEDS_PWM shall connect to TWL4030, GPIO6/PWM0, ball M4.

N900 has 22k pull-up to 1V8 on PROXY. SFH7741 data sheet says 10 kOhm to 1 MOhm is fine, so we just leave the pulling to the OMAP, Ipull(min) = 50 uA = 36 kOhm @1.8 V.

TODO: check choke

not shown here: Camera, Touch, LEDs

Sheet: /Display-Panel&Power/		
File: neo900_SS_25.sch		
Title: Display-Panel&Power		
Size: A3	Date: 2016-10-31 22:21:41	Rev:
Plotted by eeshow 01a1b57+ 20161103-02:14Z		Id: 25/37

OMAP is not part of v2

Sheet: ./CPU + PoP RAM/NAND/ File: neo900_SS_26.sch		
Title: CPU + PoP RAM/NAND		
Size: A3	Date: 2016-10-31 08:32:45	Rev:
Plotted by eeshow 01a1b57+ 20161103-02:14Z		Id: 26/37

eMMC is not part of v2

Sheet: /eMMC/		
File: neo900_SS_27.sch		
Title: eMMC		
Size: A3	Date: 2016-10-31 08:32:45	Rev:
Plotted by eeshow 01a1b57+ 20161103-02:14Z		Id: 27/37

Companion chip (TPS65950) is not part of v2

Sheet: /PMU+Codec/		
File: neo900_SS_28.sch		
Title: PMU+Codec		
Size: A3	Date: 2016-10-31 08:32:45	Rev:
Plotted by eeshow 01a1b57+ 20161103-02:14Z		Id: 28/37

simple capless 400mA LDO for TPS65950 substitute
(only for prototype)

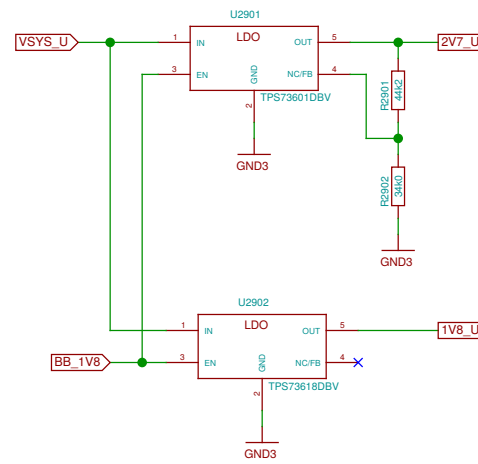

TODO: use REGEN ?

Sheet: /BB-XM Dummy (TWL4030/		
File: neo900_SS_29.sch		
Title: BB-XM Dummy (TWL4030)		
Size: A3	Date: 2016-10-31 08:32:45	Rev:
Plotted by eeshow 01a1b57+ 20161103-02:14Z		Id: 29/37

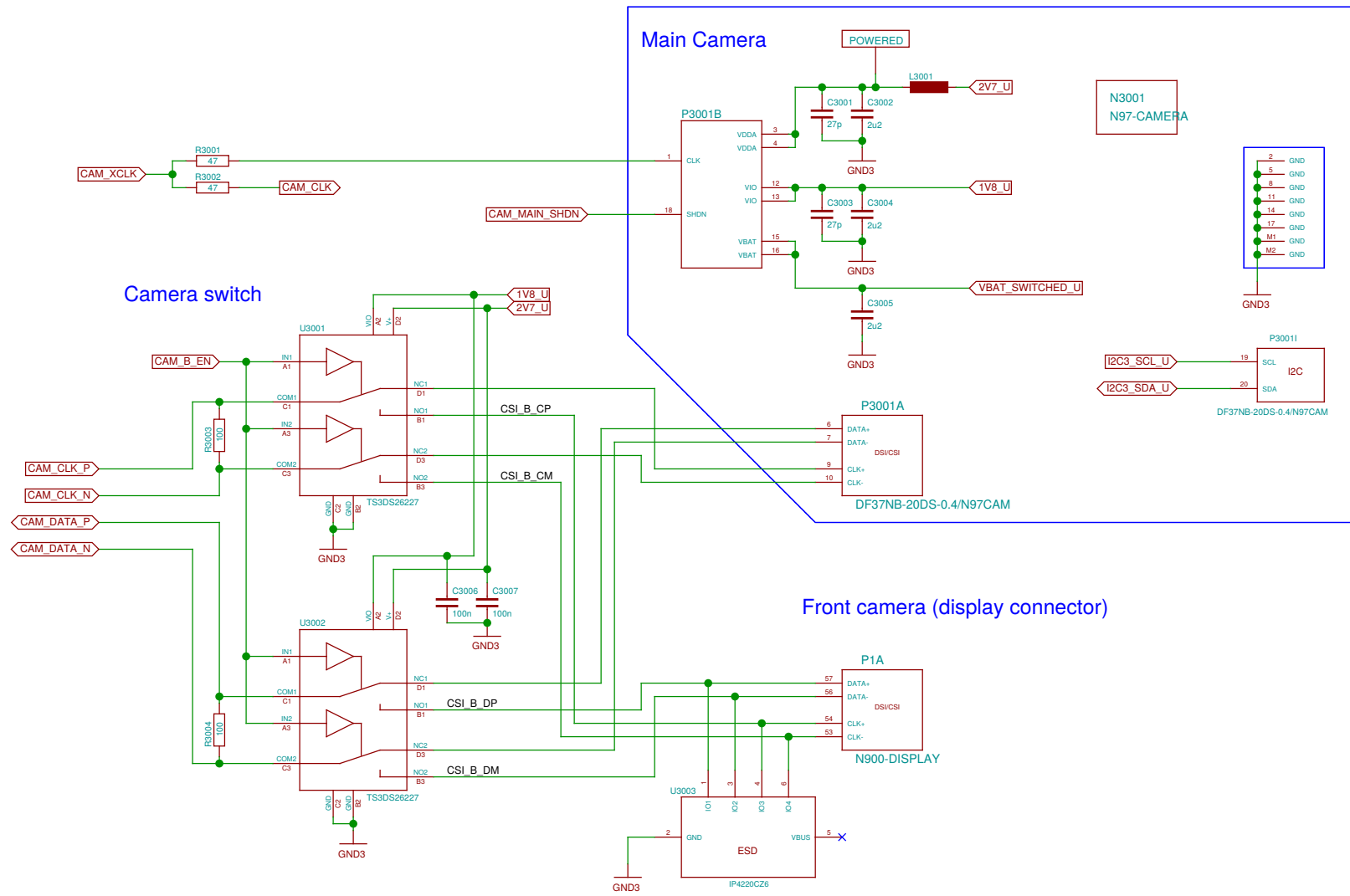

Sheet: ./Camera/ File: neo900_SS_30.sch		
Title: Camera		
Size: A3	Date: 2016-10-31 08:32:45	Rev:
Plotted by eeshow 01a1b57+ 20161103-02:14Z		Id: 30/37

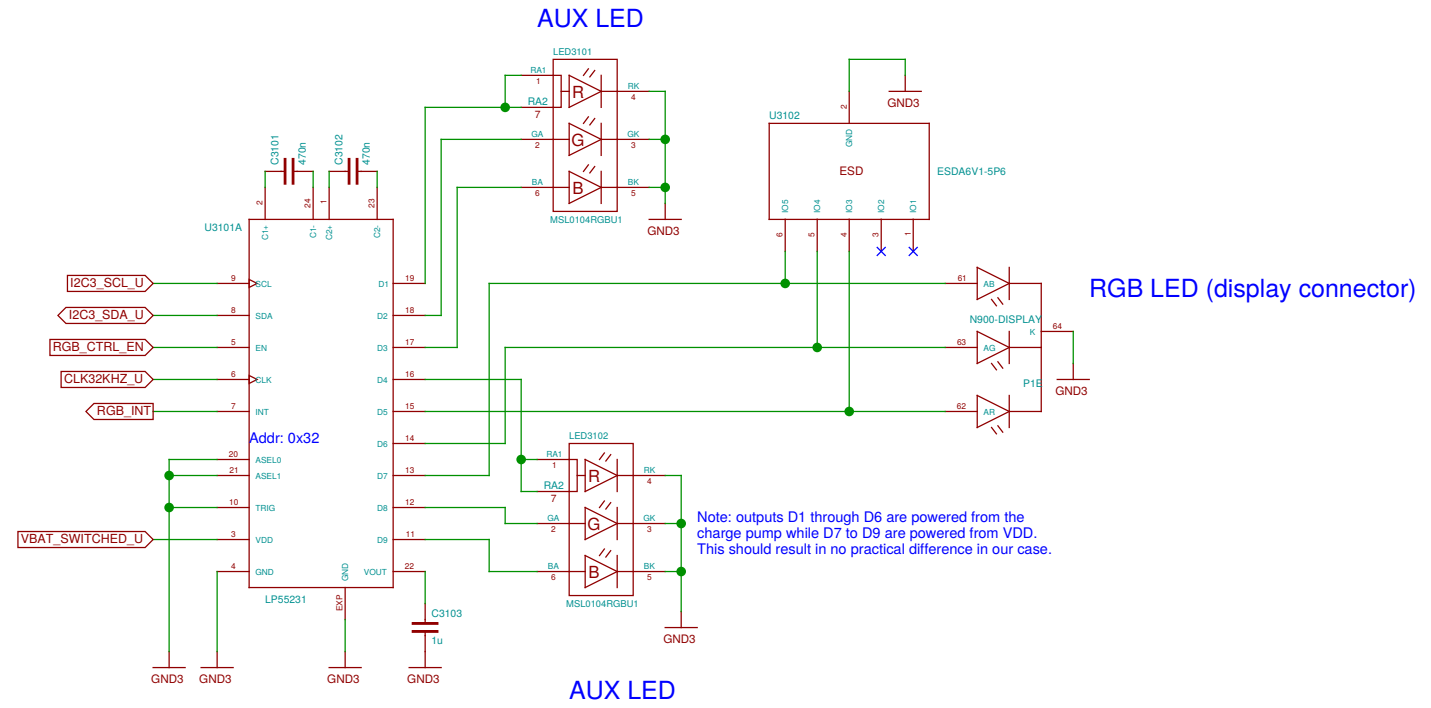

Sheet: /Fancy LEDs/		
File: neo900_SS_31.sch		
Title: Fancy LEDs		
Size: A3	Date: 2016-10-31 19:05:55	Rev:
Plotted by eeshow 01a1b57+ 20161103-02:14Z		Id: 31/37

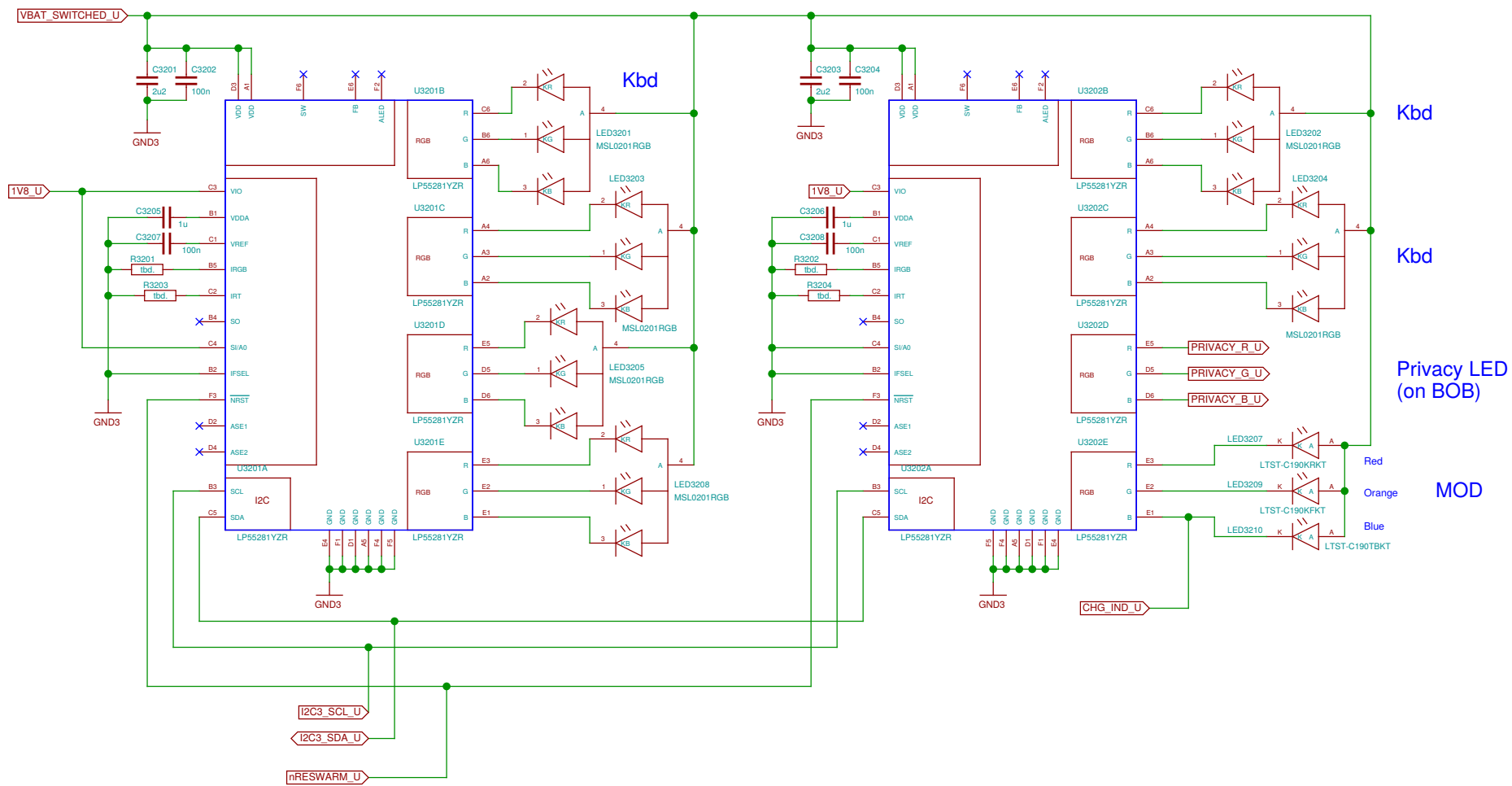

Cleaning up. The connections to BB-xM are on the next sheets.

connect to BB
by some Micro-USB cable

Modem USB

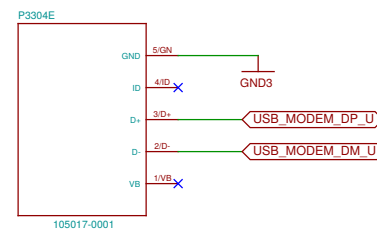

32 kHz clock

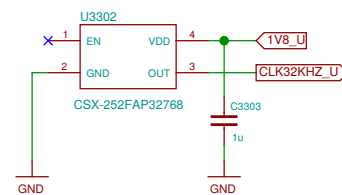

Alternative: OYKTGLJANF-0.032768

Sheet: ./Connector to BB-XM/ File: neo900_SS_33.sch		
Title: Connector to BB-XM		
Size: A3	Date: 2016-10-31 08:32:45	Rev:
Plotted by eeshow 01a1b57+ 20161103-02:14Z		Id: 33/37

TODO: update pin names in footprint

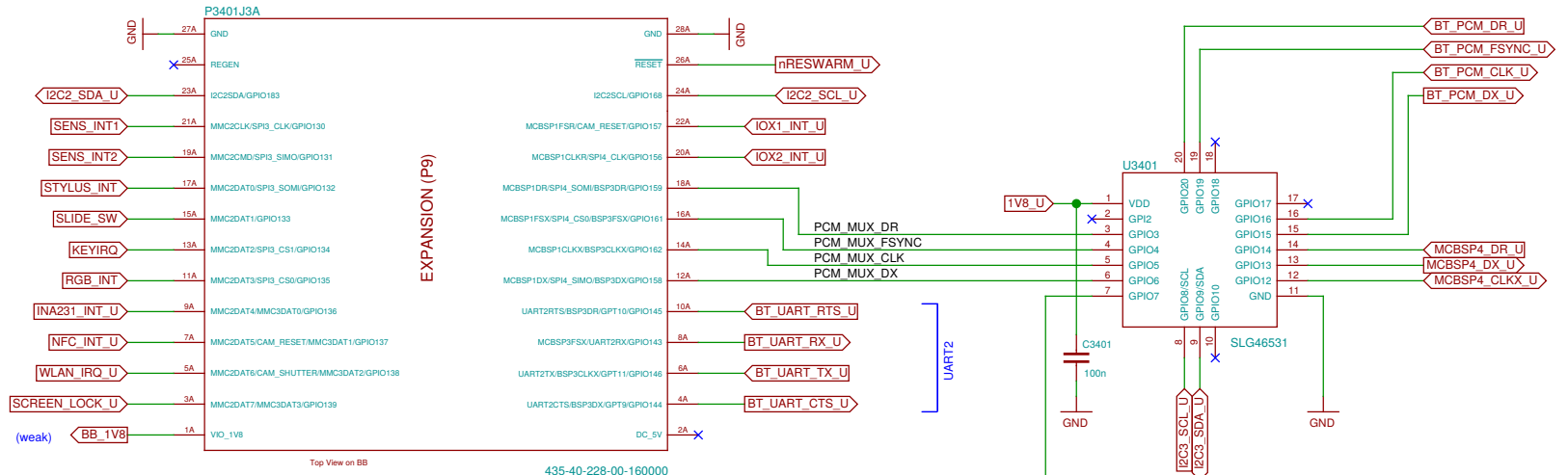
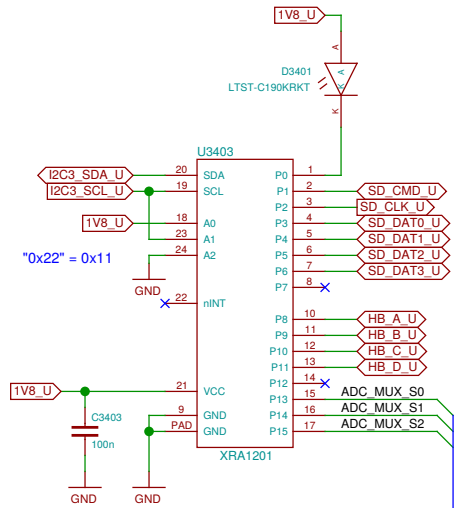

Same part, as "breakaway" strip (72 positions):
435-40-272-00-160000

BB-xM Main Expansion Header (P9, 7.24)

Auxiliary Expansion Header (P17, 7.26)

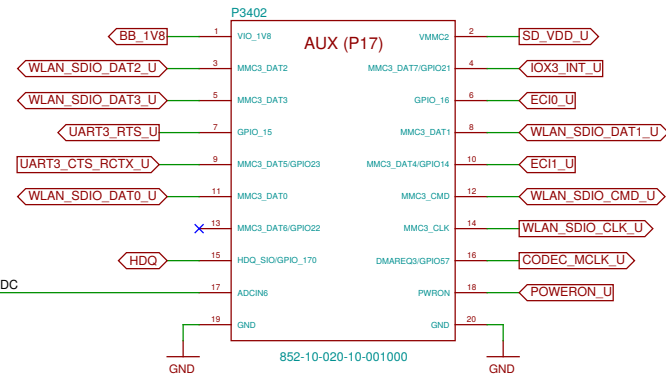

Same part, as "breakaway" strip (100 positions):
852-10-1000-10-001000

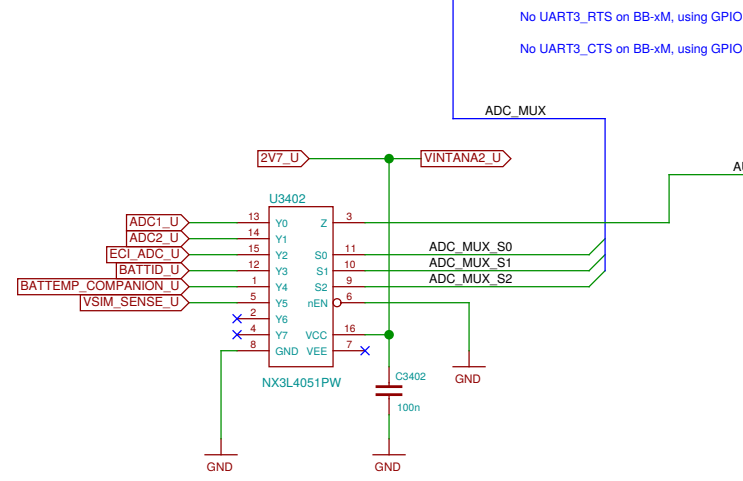

FM_nINT (on IO expander)

Sheet: /BB-XM Adapter (CPU)		
File: neo900_SS_34.sch		
Title: BB-XM Adapter (CPU)		
Size: A3	Date: 2016-11-04 01:46:51	Rev:
Plotted by eeshow 01a1b57+ 20161103-02:14Z		Id: 34/37

P11 (7.25)

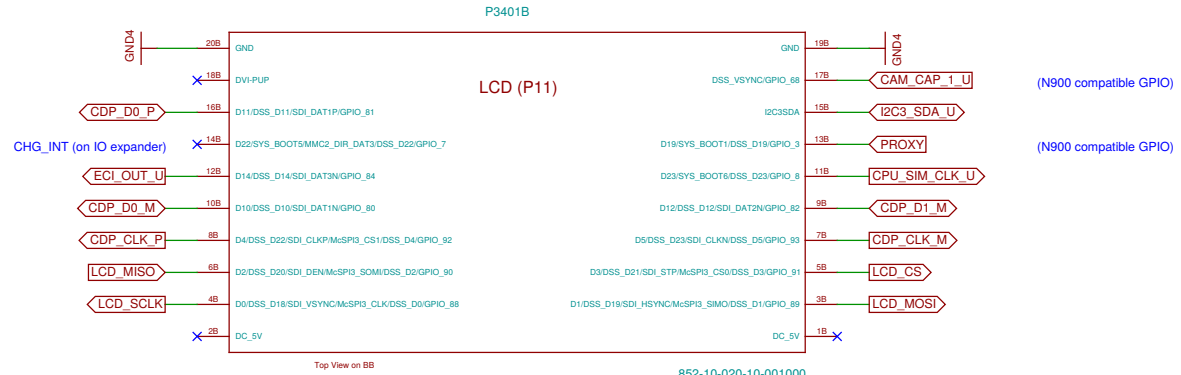

852-10-020-10-001000
Same part, as "breakaway" strip (100 positions):
852-10-1000-10-001000

P13 (7.25)

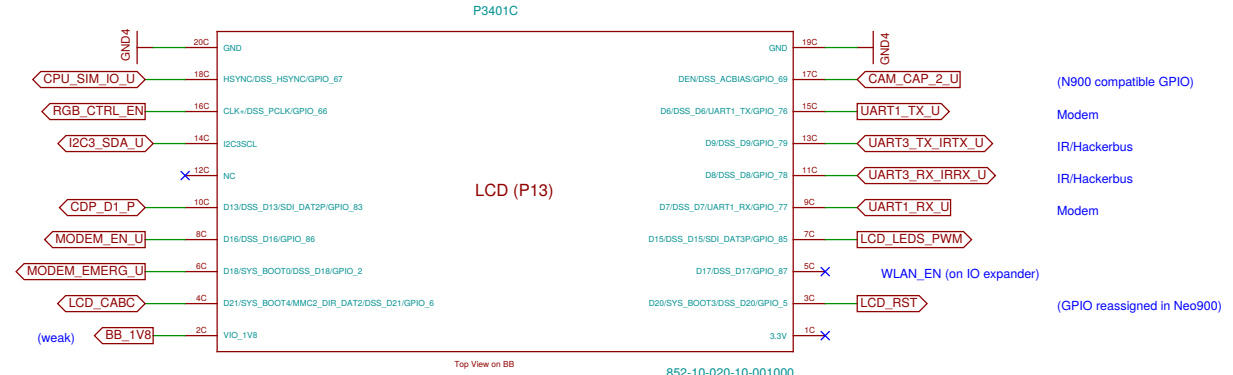

852-10-020-10-001000
Same part, as "breakaway" strip (100 positions):
852-10-1000-10-001000

TODO: update pin names in footprint

Sheet: /BB-XM Adapter (DISP)/		
File: neo900_SS_35.sch		
Title: BB-XM Adapter (DISP)		
Size: A3	Date: 2016-10-31 08:32:45	Rev:
Plotted by eeshow 01a1b57+ 20161103-02:14Z		Id: 35/37

Processor Camera Port Interface (P10, 7.20.3)

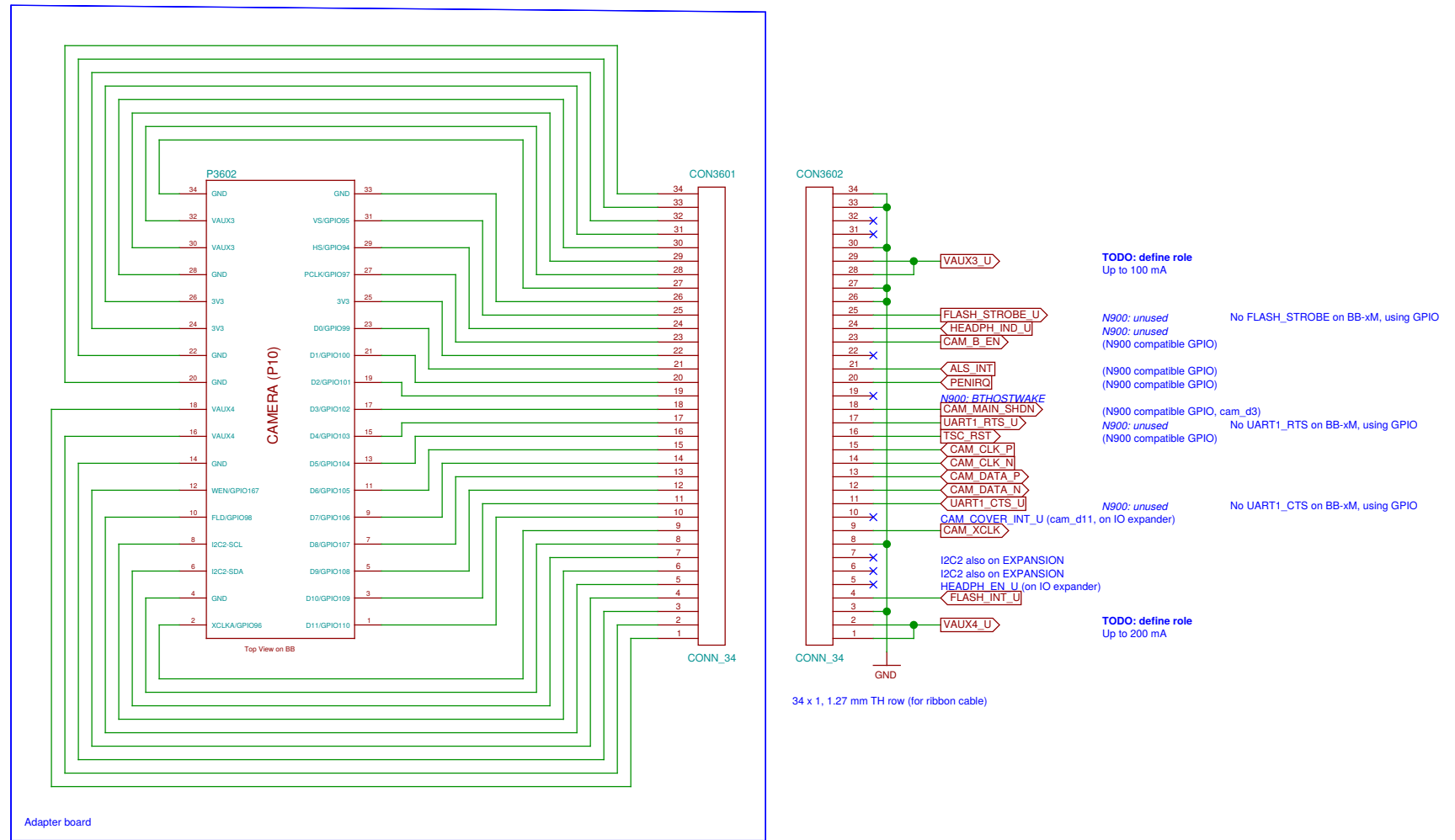

TODO: update pin names in footprint

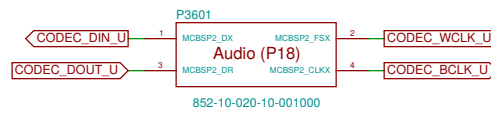

This part is a "breakaway" strip (20 positions) and needs to be customized (cut) before assembly. Alternatively, 852-10-100-10-001000 (100 positions) could be used.

Sheet: /BB-XM Adapter (CAM)/		
File: neo900_SS_36.sch		
Title: BB-XM Adapter (CAM)		
Size: A3	Date: 2016-10-31 08:32:45	Rev:
Plotted by eeshow 01a1b57+ 20161103-02:14Z		Id: 36/37

Molex Jumper cables to connect BB-XM-Adapter to Uppwer board

N3701 15015-0439	N3702 15015-0439	N3703 15015-0439
CPU	DISP	CAM

N3704 N900 case assembly

N3705 N97-CAMERA-HOLE

N3706 headset jack

N3707 STENCIL-TOP

N3708 STENCIL-BOTTOM
