

Click | Here
V

This sheet: index

Sheet: Charger/OTG



Charger/OTG

File: charger.sch

Sheet: Battery



Battery

File: battery.sch

Sheet: Modem Power



Modem Power

File: modempwr.sch

Sheet: 3G/4G Modem



3G/4G Modem

File: modem.sch

Sheet: SIM cards and switch



SIM cards and switch

File: sims.sch

Sheet: Modem Antennas



Modem Antennas

File: ants.sch

Sheet: WLAN, Bluetooth, FM



WLAN, Bluetooth, FM

File: wlan.sch

Sheet: Sensors



Sensors

File: sensors.sch

Sheet: Audio Codec



Audio Codec

File: codec.sch

Sheet: Audio Headset, ECI



Audio Headset, ECI

File: jack.sch

Sheet: Misc



Misc

File: misc.sch

Click | Here
V

Sheet: RFID/NFC



RFID/NFC

File: nfc.sch

Sheet: Infrared



Infrared

File: ir.sch

Sheet: B2B LOWER-UPPER



B2B LOWER-UPPER

File: b2b.sch

Sheet: Hackerbus



Hackerbus

File: hb.sch

Sheet: uSD Breakout Board



uSD Breakout Board

File: bob.sch

Sheet: Keypad and buttons



Keypad and buttons

File: keys.sch

Sheet: Display



Display

File: display.sch

Sheet: Cameras



Cameras

File: cams.sch

Sheet: LEDs



LEDs

File: leds.sch

Click | Here
V

Sheet: Adaptation (v2 only)



Adaptation (v2 only)

File: v2.sch

Sheet: BB-xM Adapter (CPU)



BB-xM Adapter (CPU)

File: bbcpu.sch

Sheet: BB-xM Adapter (DISP)



BB-xM Adapter (DISP)

File: bbdisp.sch

Sheet: BB-xM Adapter (CAM)



BB-xM Adapter (CAM)

File: bbcam.sch

Circuits that exist in the v2 prototype only
and that will not be part of the final design.

Note regarding I2C addresses:
Addresses in the schematics are provided for convenience.
The authoritative source is
<https://neo900.org/git/misc/tree/i2c>

Signals that exist on both LOWER and UPPER (and maybe also BOB)
have a _U suffix on UPPER. No suffix is needed to distinguish
between LOWER and BOB because all BOB components are on
the same sheet and wires connecting them use sheet-local labels.

Sheet: /			
File: neo900.sch			
Title: Neo900			
Size: A3	Date: 2016-11-18 15:49:26	Rev:	
Plotted by eeshow afac499+ 20161129-04:04Z			Id: 1/25

USB OTG connector

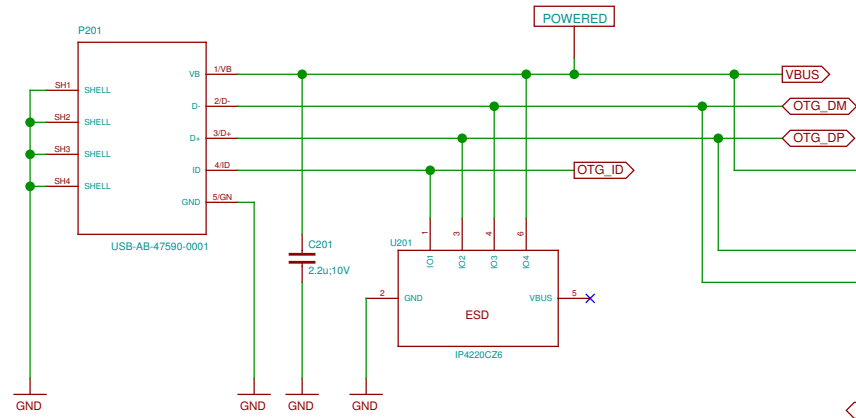

Battery charger with USB OTG

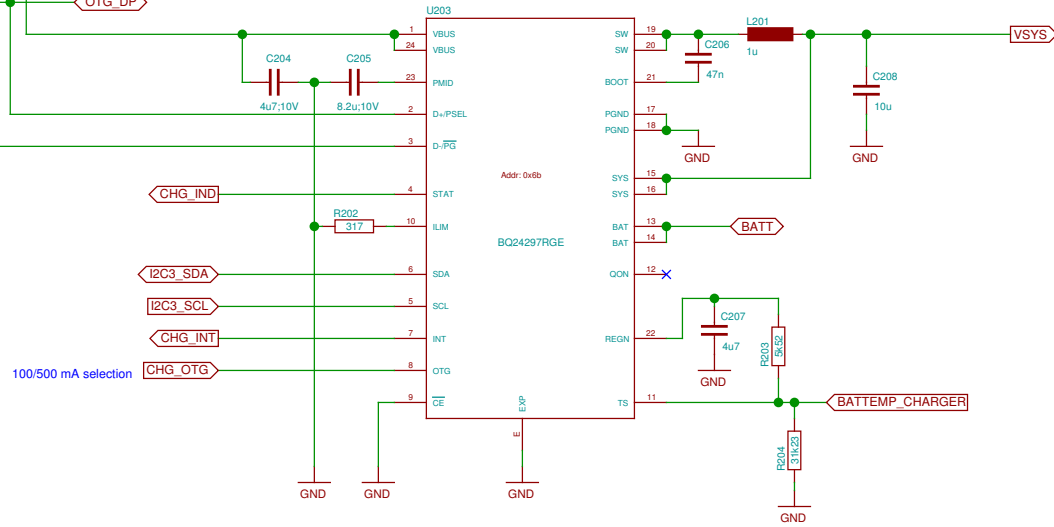

Power distribution and sequencing

Most high-current consumers are on VBAT_SWITCHED.
1V8 signals that the regulators on UPPER are operational.

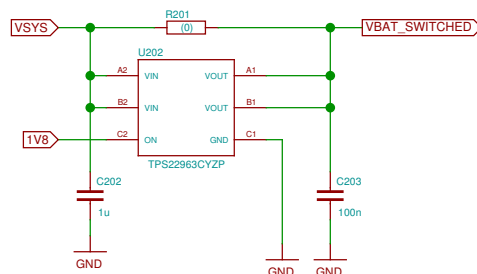

KiCad bureaucracy

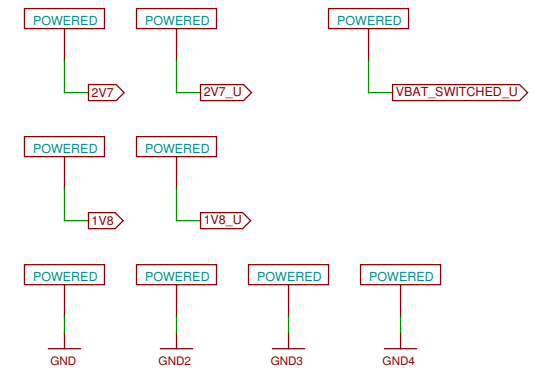

Sheet: /Charger/OTG/		File: charger.sch	
Title: Charger/OTG			
Size: A3	Date: 2016-11-18 15:49:26	Rev:	
Plotted by eeshow afac499+ 20161129-04:04Z			Id: 2/25

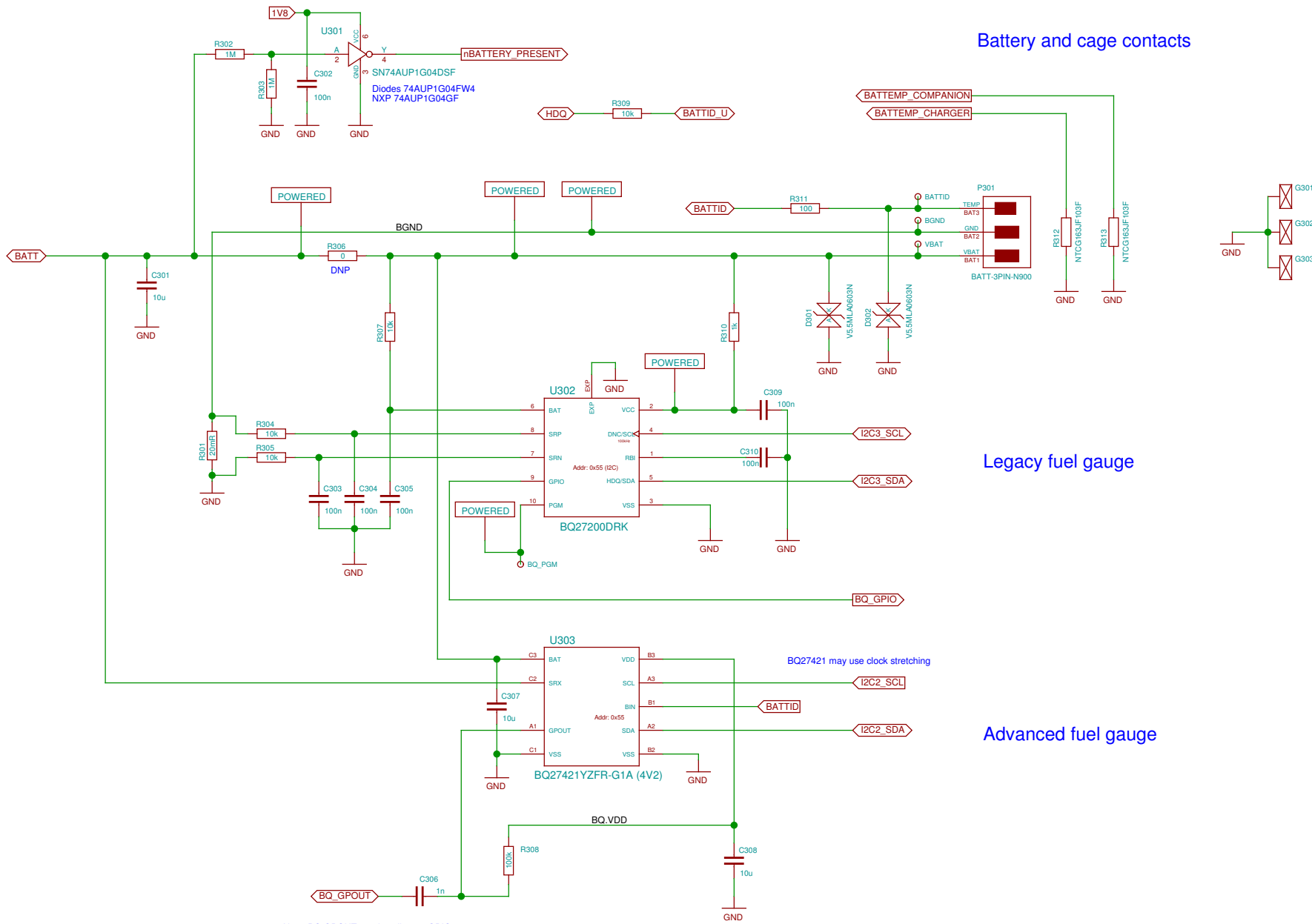

Note: BQ.GPOUT needs pull-up at GPIO.

Battery and cage contacts

Legacy fuel gauge

Advanced fuel gauge

Modem current monitor

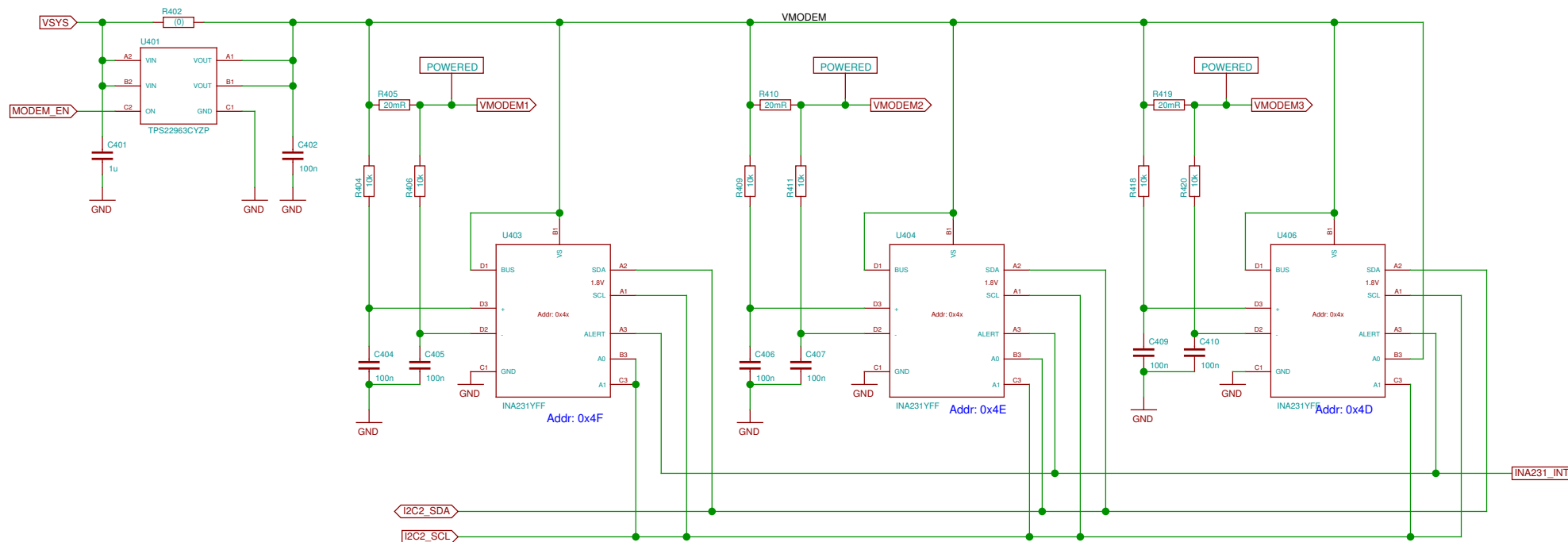

SIM current sensing

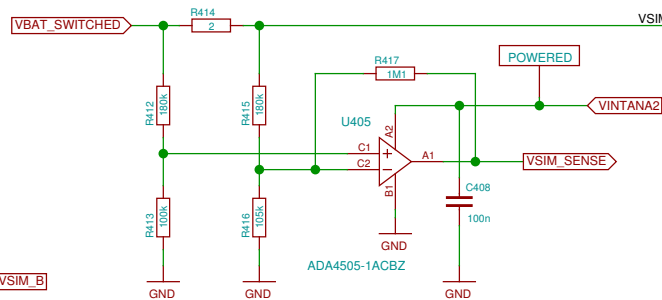

SIM power supply

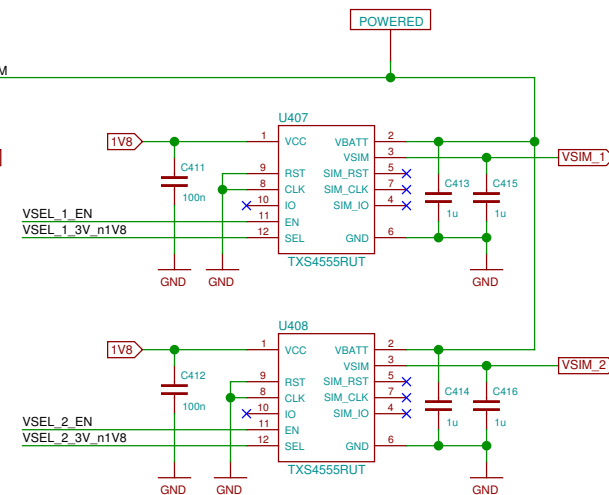

SIM power selection

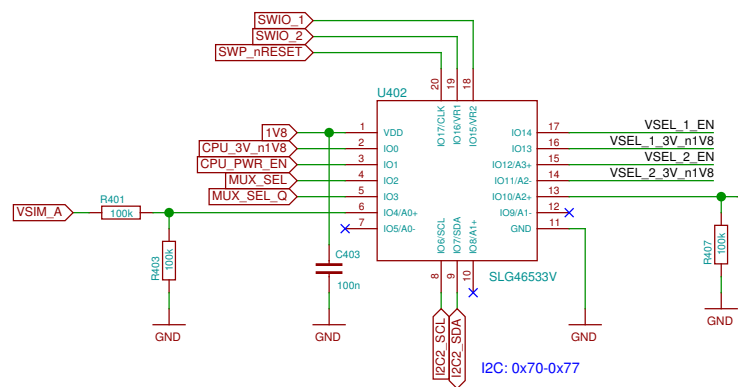

SIM B bus

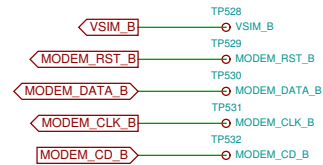

17+10+10 = 37 test points. PCB space permitting, to be arranged a 6 x 6 + 1 grid with 1.0 mm pitch. This patch field is to be placed adjacent to the SIM B bus test points.

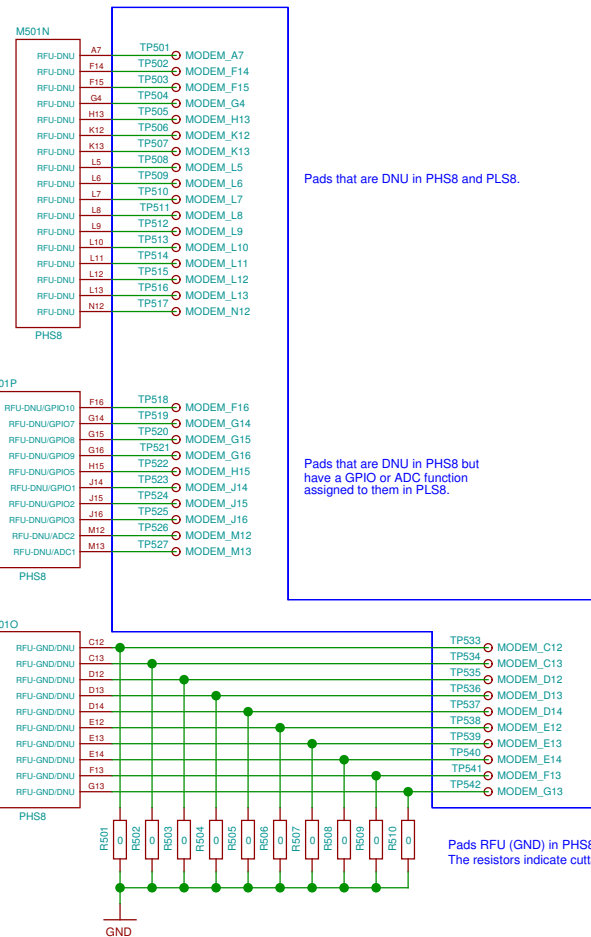

Modem (module)

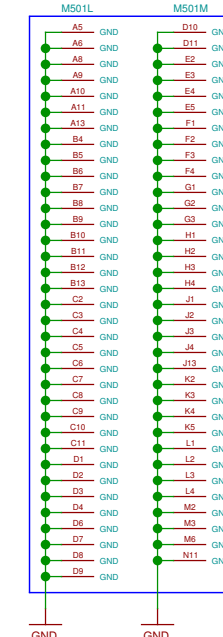
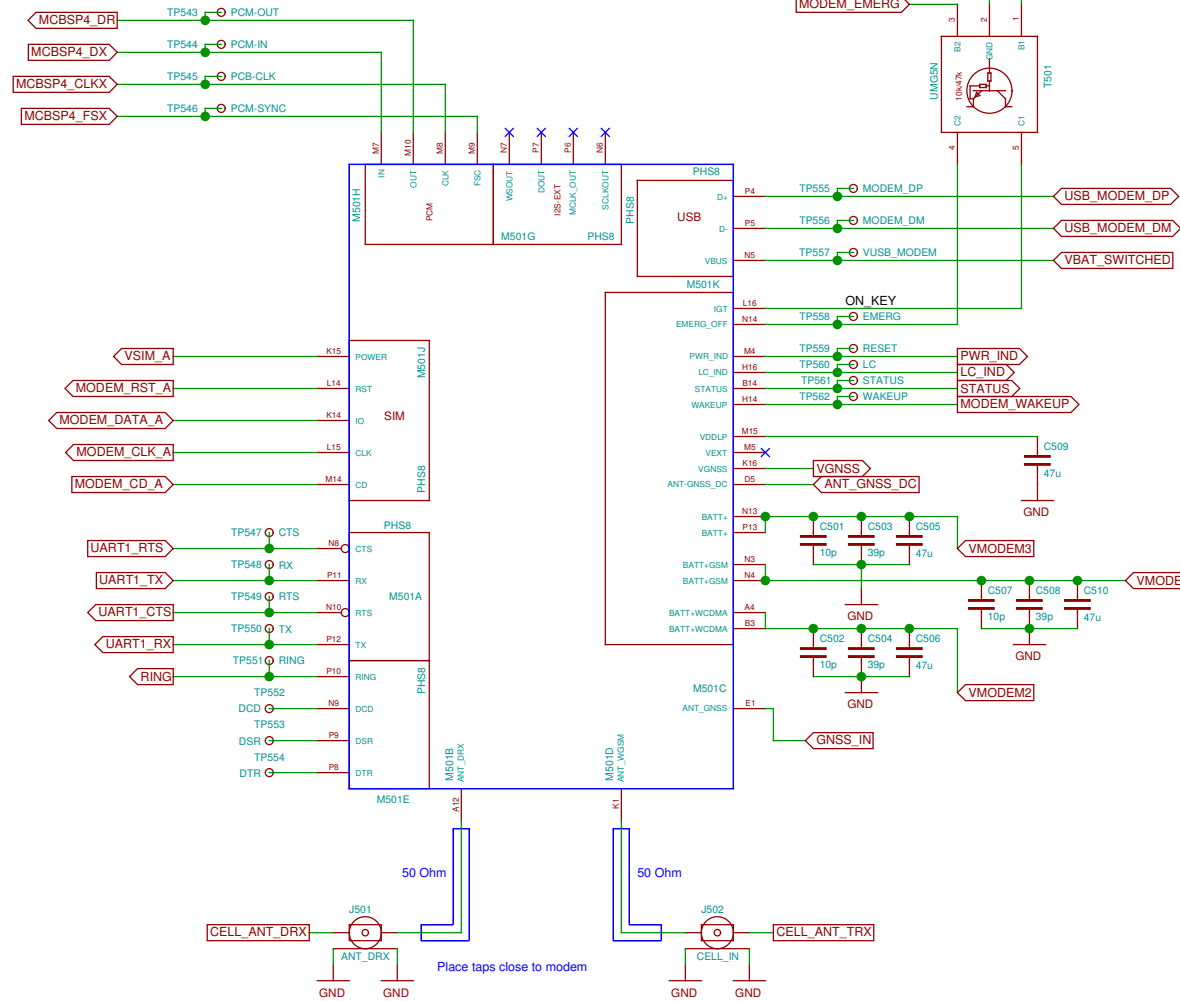

Anti-eavesdropping

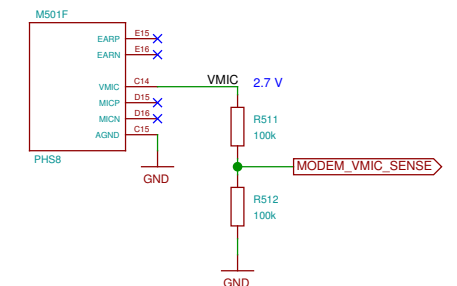

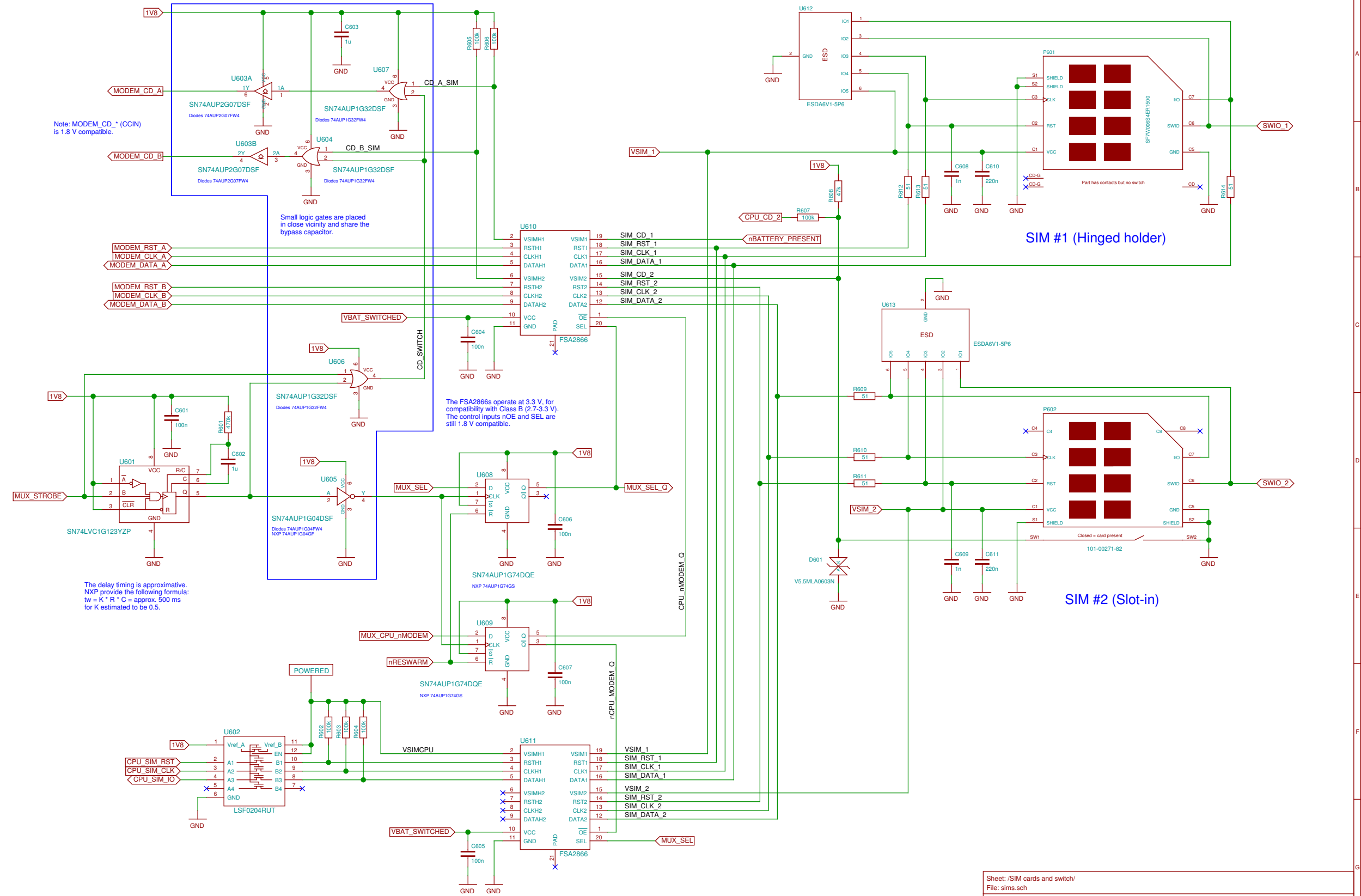

Note: MODEM_CD_* (CCIN) is 1.8 V compatible.

Small logic gates are placed in close vicinity and share the bypass capacitor.

The FSA2866s operate at 3.3 V, for compatibility with Class B (2.7-3.3 V). The control inputs nOE and SEL are still 1.8 V compatible.

The delay timing is approximative. NXP provide the following formula: $t_w = K * R * C \approx \text{approx. } 500 \text{ ms}$ for K estimated to be 0.5.

SIM #1 (Hinged holder)

SIM #2 (Slot-in)

Sheet: /SIM cards and switch/		
File: sims.sch		
Title: SIM cards and switch		
Size: A3	Date: 2016-11-21 23:56:50	Rev:
Plotted by eeshow afac499 - 20161129-04:04Z		Id: 6/25

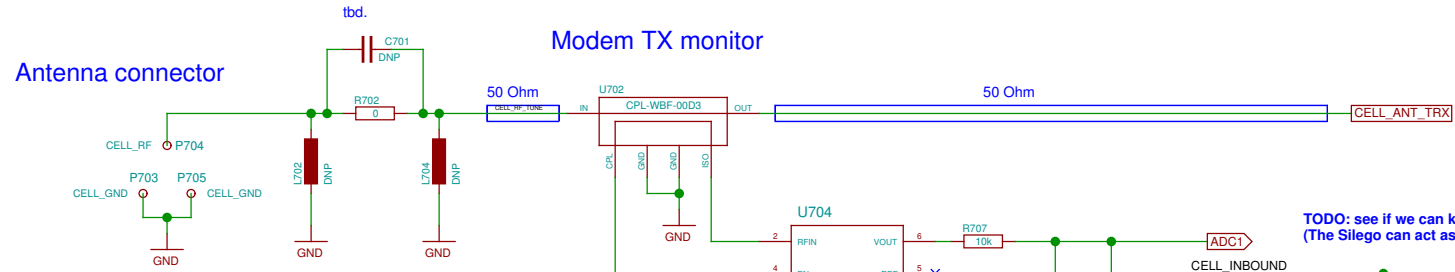
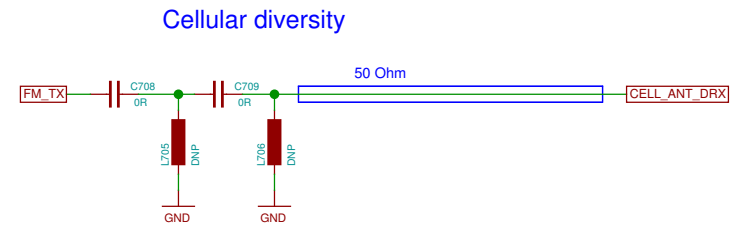
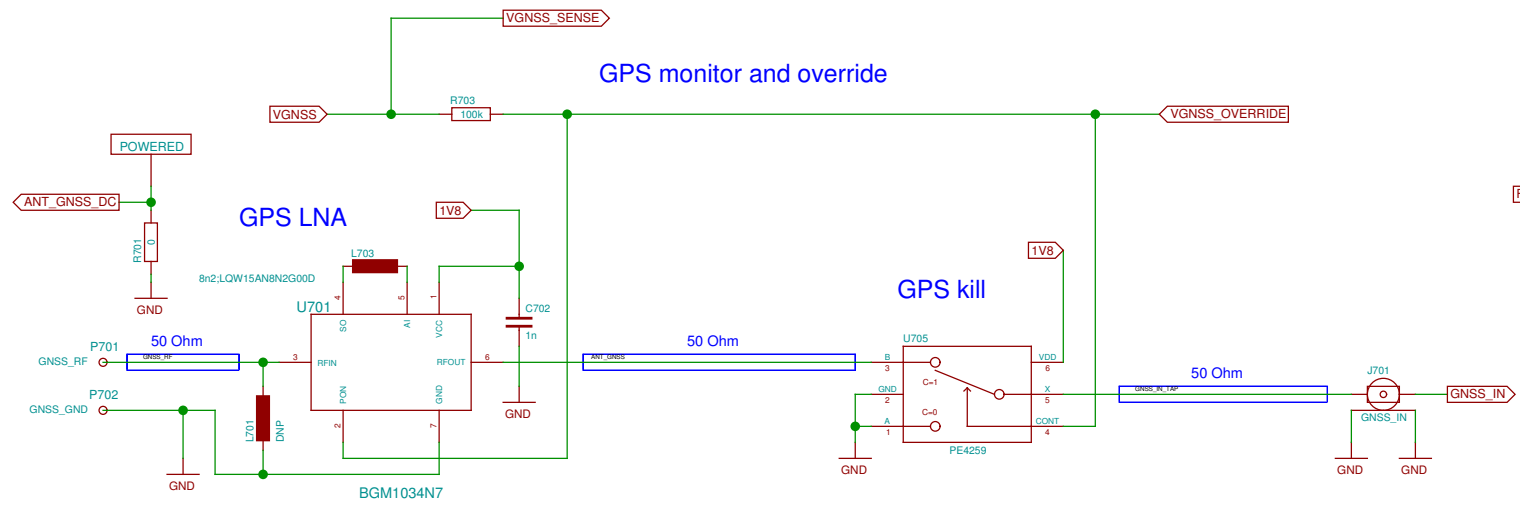

Modem TX monitor

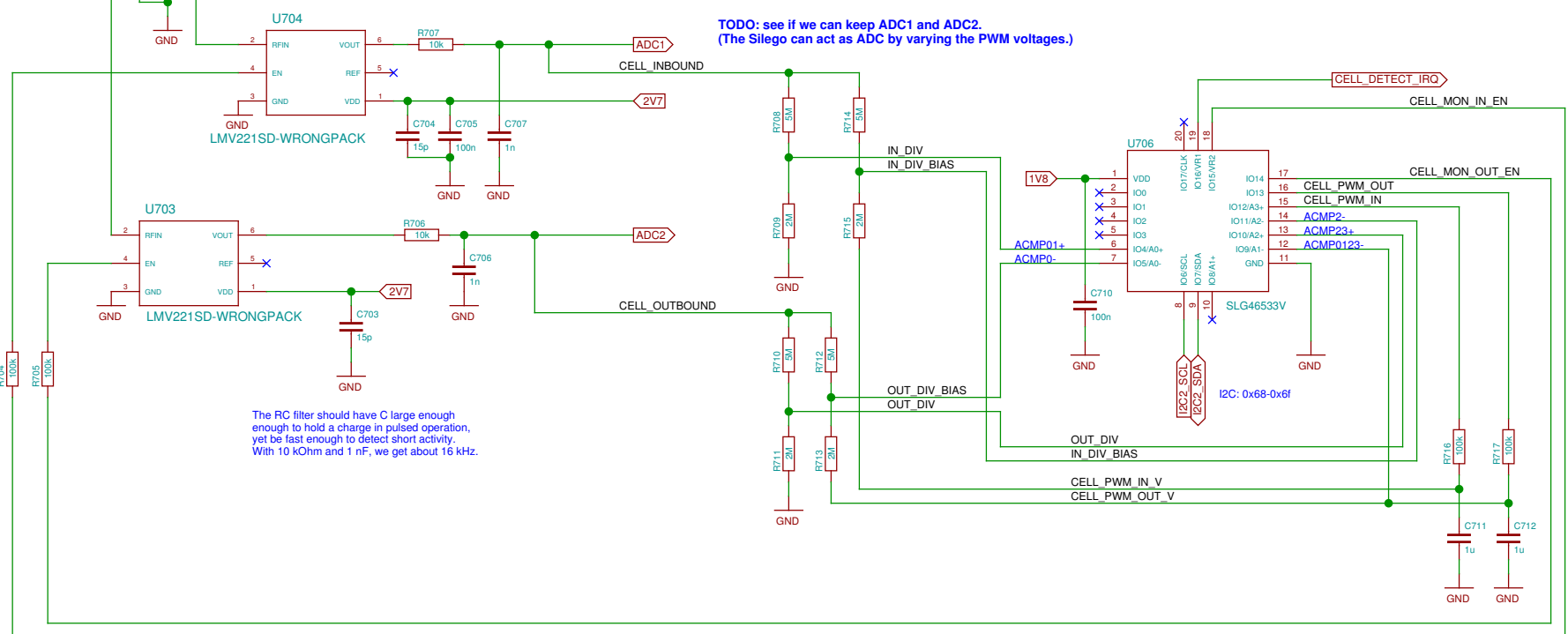

TODO: see if we can keep ADC1 and ADC2.
(The Silago can act as ADC by varying the PWM voltages.)

TODO: assign footprints for c-spring contacts

WLAN/BT antenna

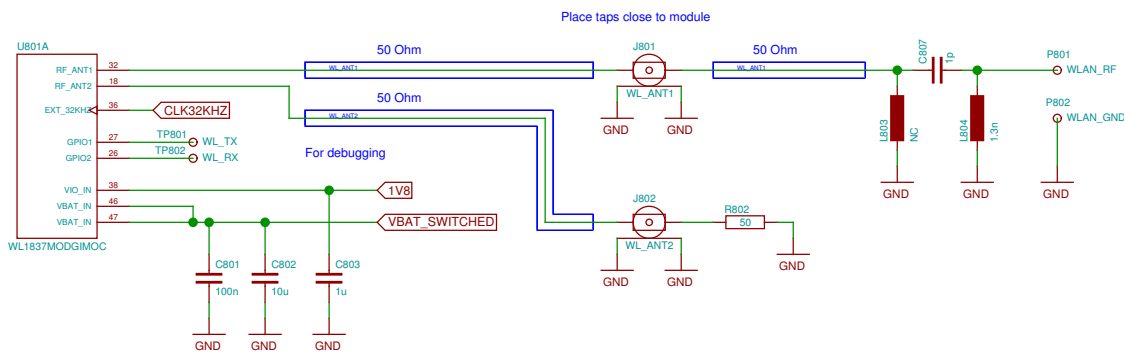

WLAN

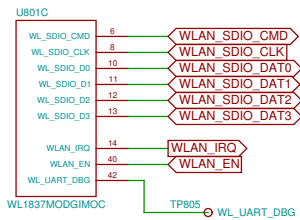

Bluetooth

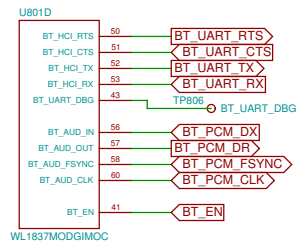

Reserved / Debugging

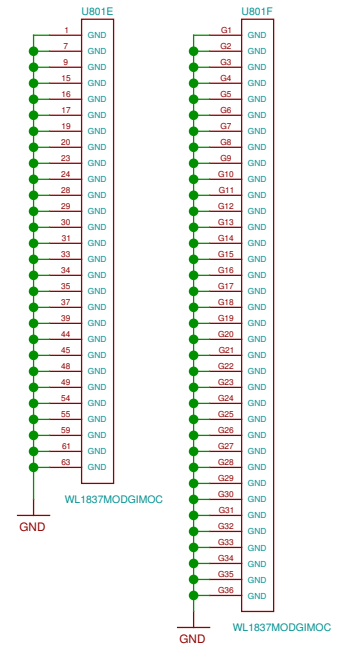
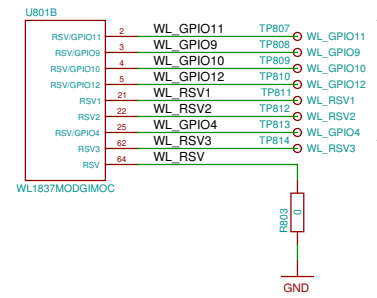

FM Radio (TX/RX)

FM TX antenna

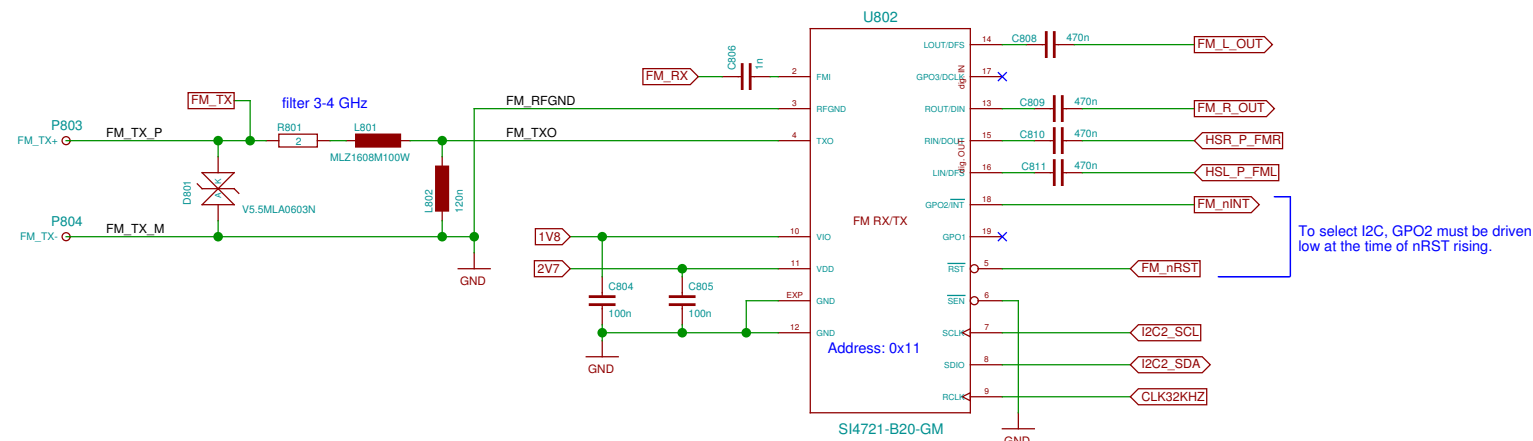

SI4705 is pin compatible (mostly) but RX-only

Acceleration (legacy)

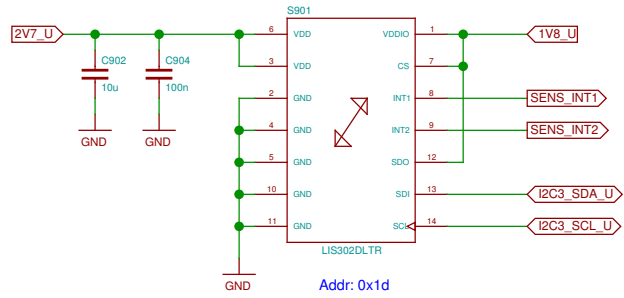

Pressure, humidity

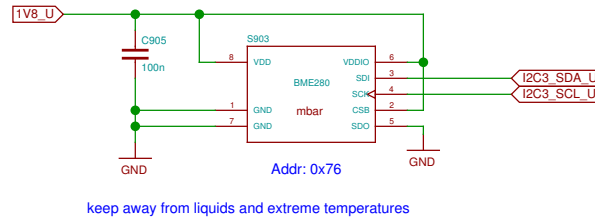

9-axis (acceleration, gyroscope, magnetometer)

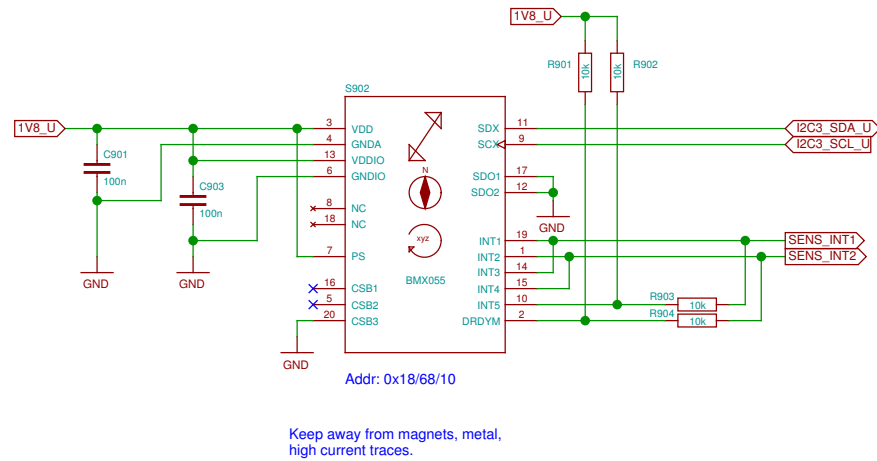

UPPER
LOWER

Stylus detect

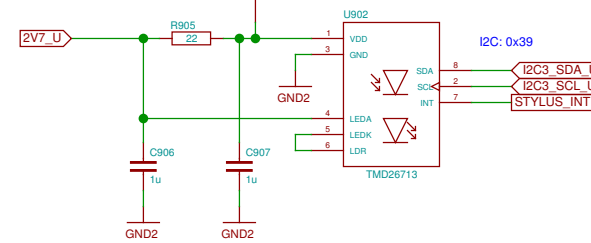

Slide sensor

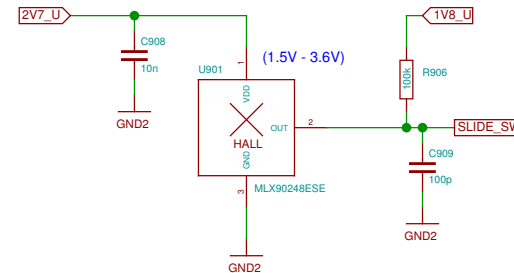

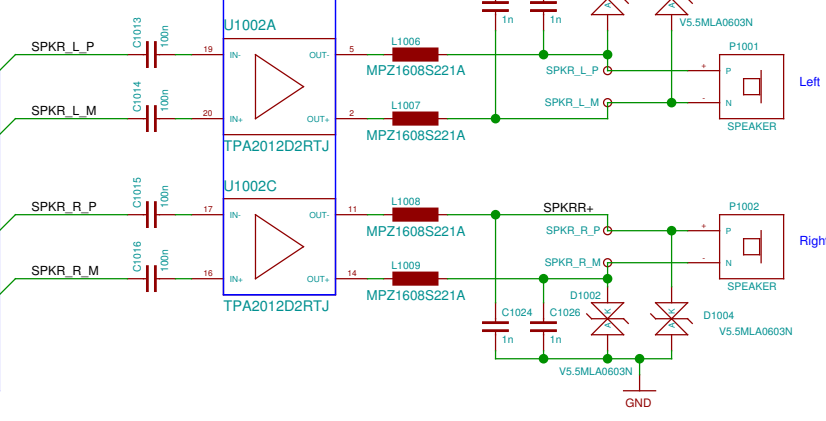
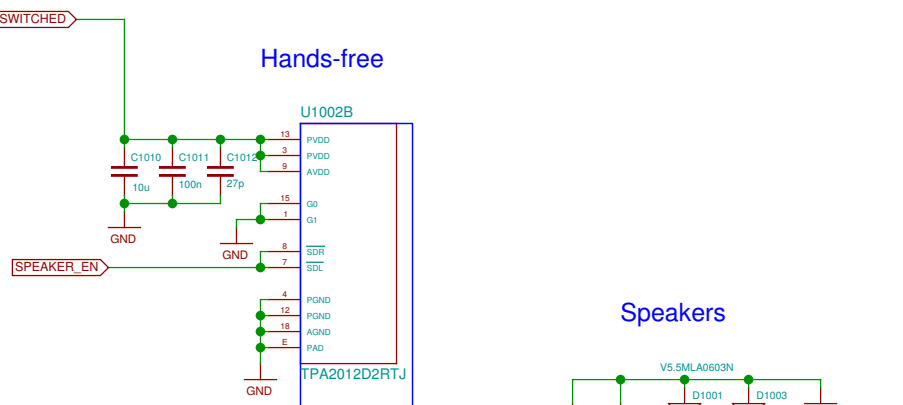
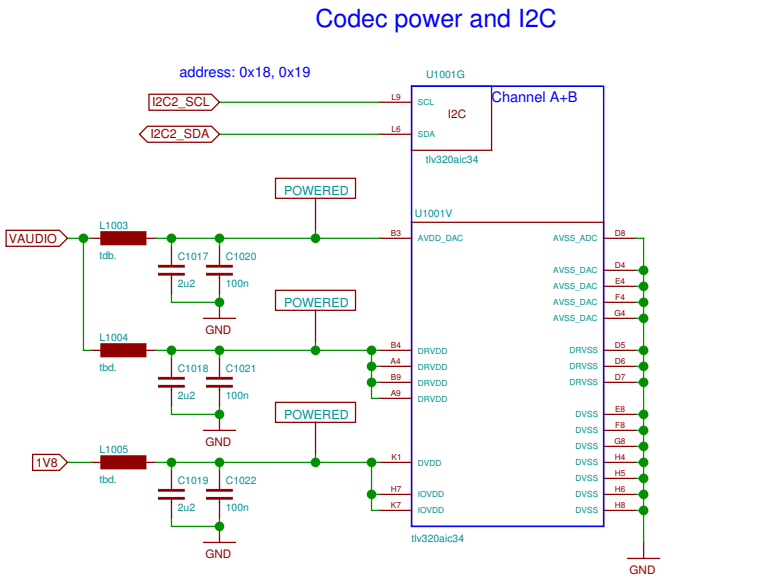
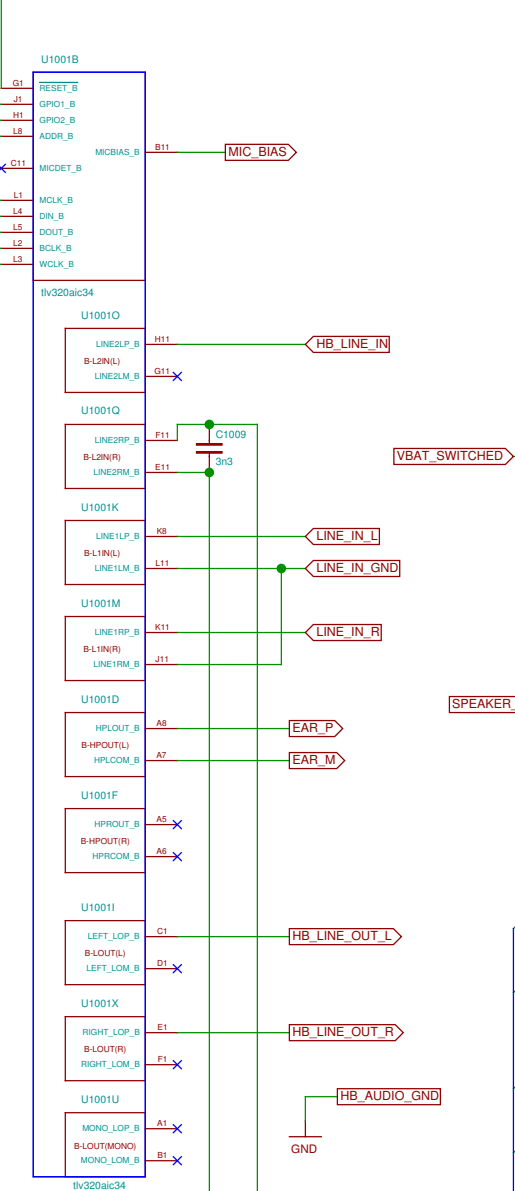
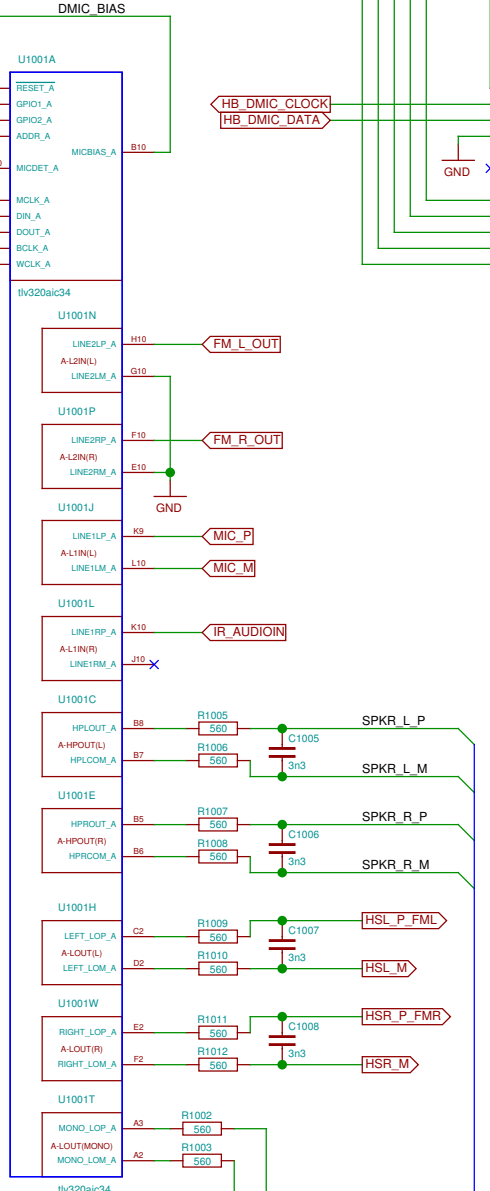
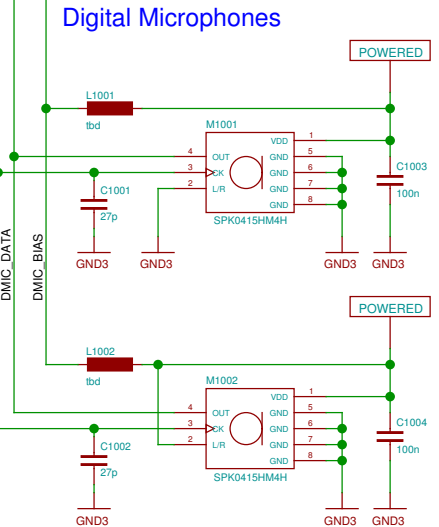
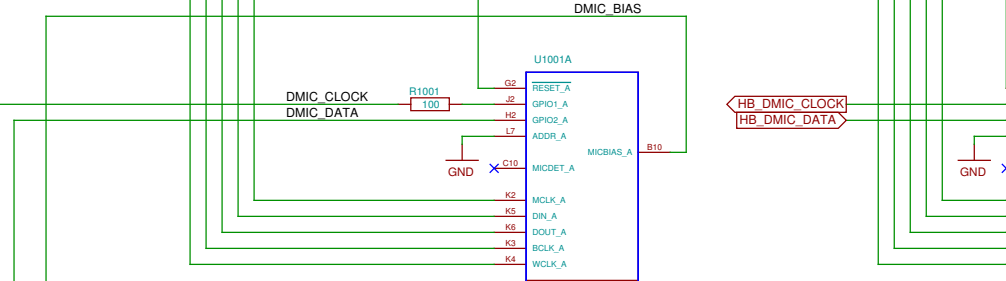
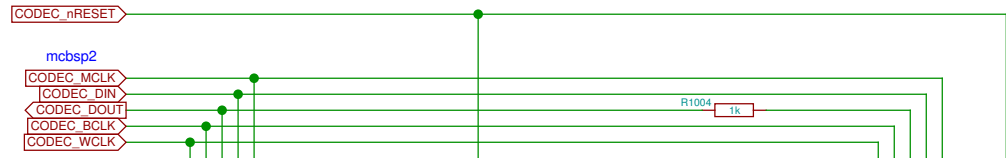

Sheet: /Audio Codec/		Date: 2016-11-18 15:49:26	
File: codec.sch		Rev: 1	
Title: Audio Codec		Id: 10/25	
Size: A3	Plotted by: eeshow afac499 - 20161129-04:04Z		

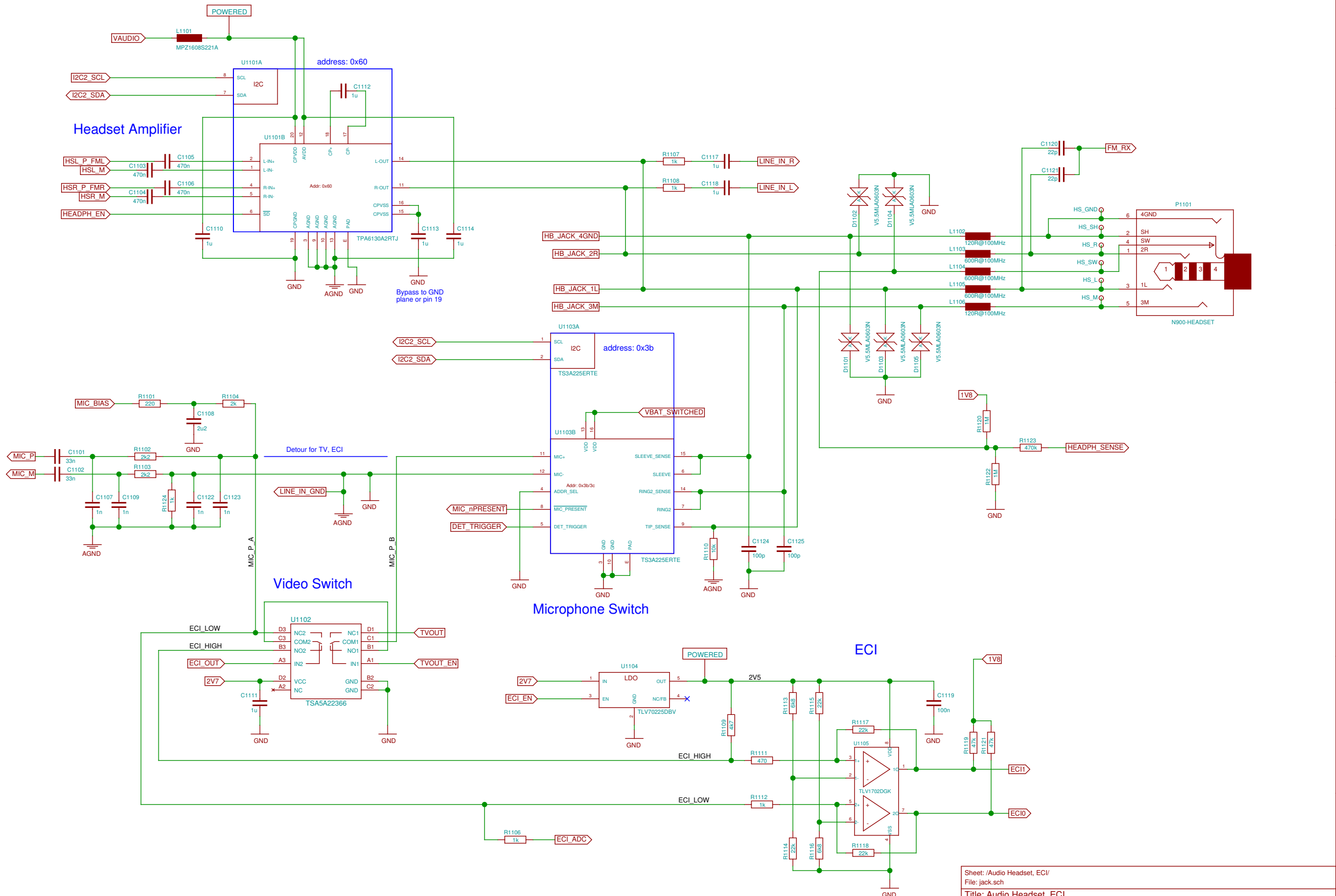

Sheet: /Audio Headset, ECI/ File: jack.sch	
Title: Audio Headset, ECI	
Size: A3	Date: 2016-11-18 15:49:26
Plotted by: eeshow afac499 - 20161129-04:04Z	Rev: Id: 11/25

No-Solder Components

N1201
N900 case assembly

N1202
N97-CAMERA-HOLE

N1205
headset jack

N1203
STENCIL-TOP

N1204
STENCIL-BOTTOM

Shield Contacts on UPPER

For the display

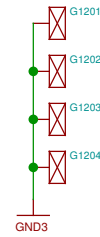

For the key mat

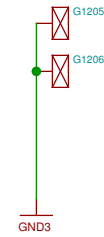

For the "key frame hook"

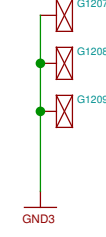

Vibramotor

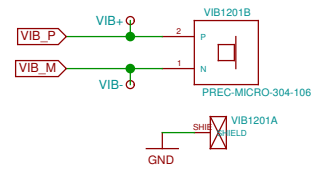

Sheet: Misc/ File: misc.sch		
Title: Misc		
Size: A3	Date: 2016-11-18 15:49:26	Rev:
Plotted by eeshow afac499+ 20161129-04:04Z		Id: 12/25

RFID/NFC Transceiver

RFID/NFC Controller

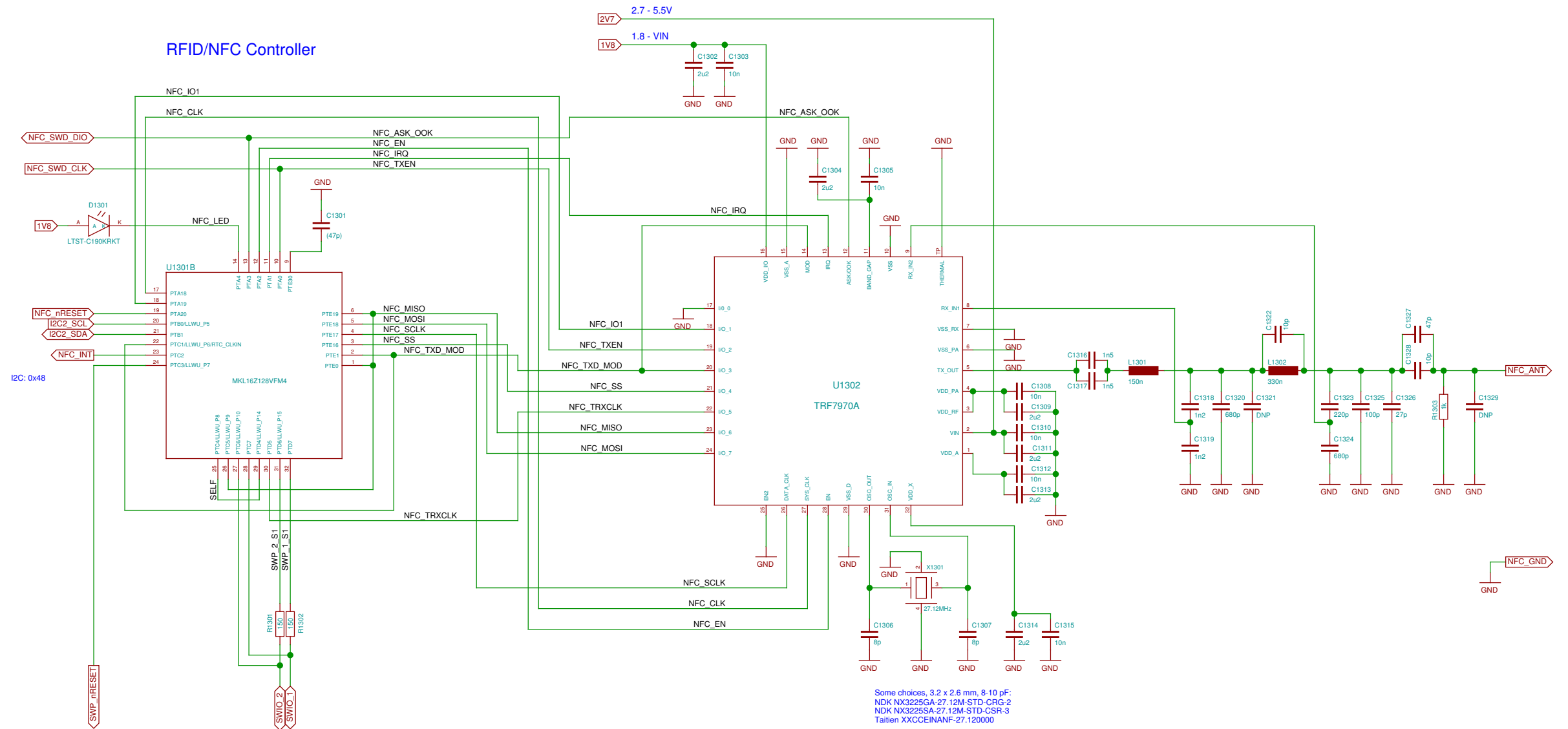

Some choices, 3.2 x 2.6 mm, 8-10 pF:
 NDK NX3225GA-27.12M-STD-CRG-2
 NDK NX3225SA-27.12M-STD-CSR-3
 Taiteien XXCCEINANF-27.120000

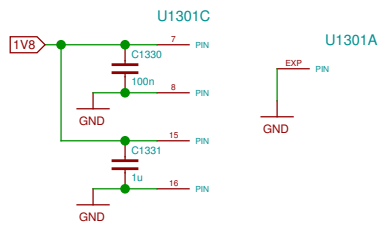

Sheet: /RFID/NFC/		File: nfc.sch	
Title: RFID/NFC			
Size: A3	Date: 2016-11-23 22:26:52	Rev:	
Plotted by eeshow afac499+ 20161129-04:04Z		Id: 13/25	

IR receiver

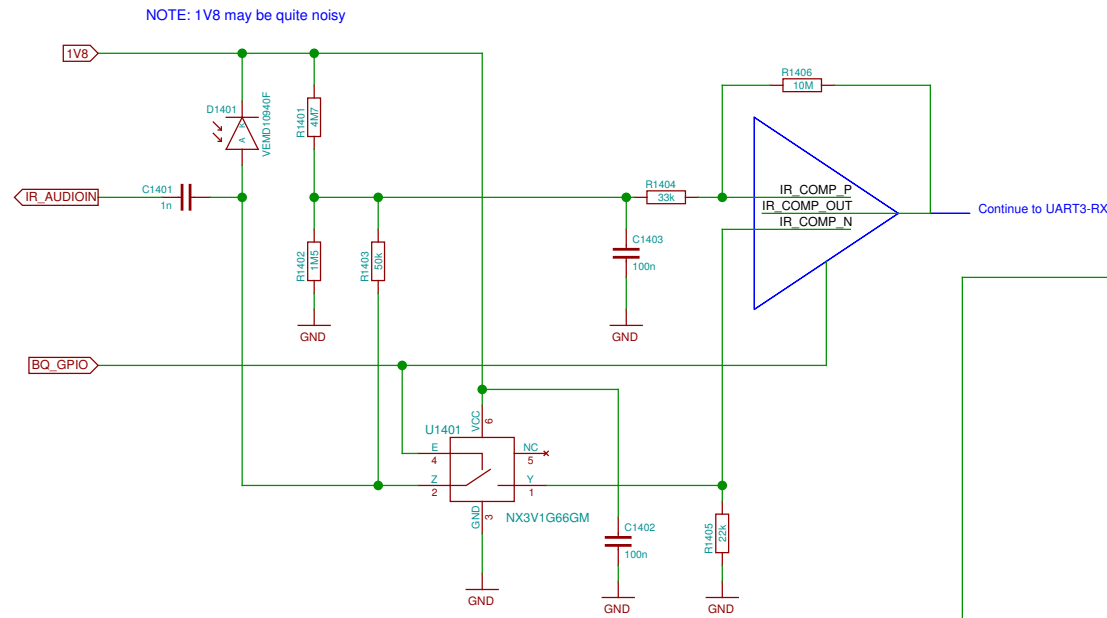

IR transmitter

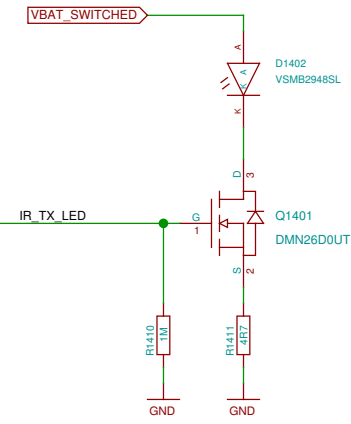

IR send/receive logic

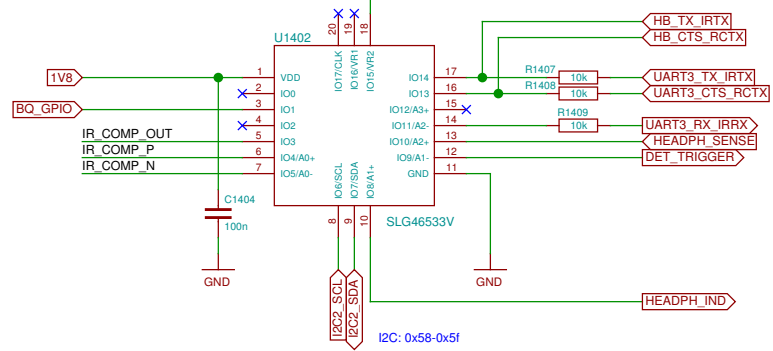

TODO: update D1401 footprint

This is just the collection of signals we have. Assignment can still change, e.g., to improve layout.

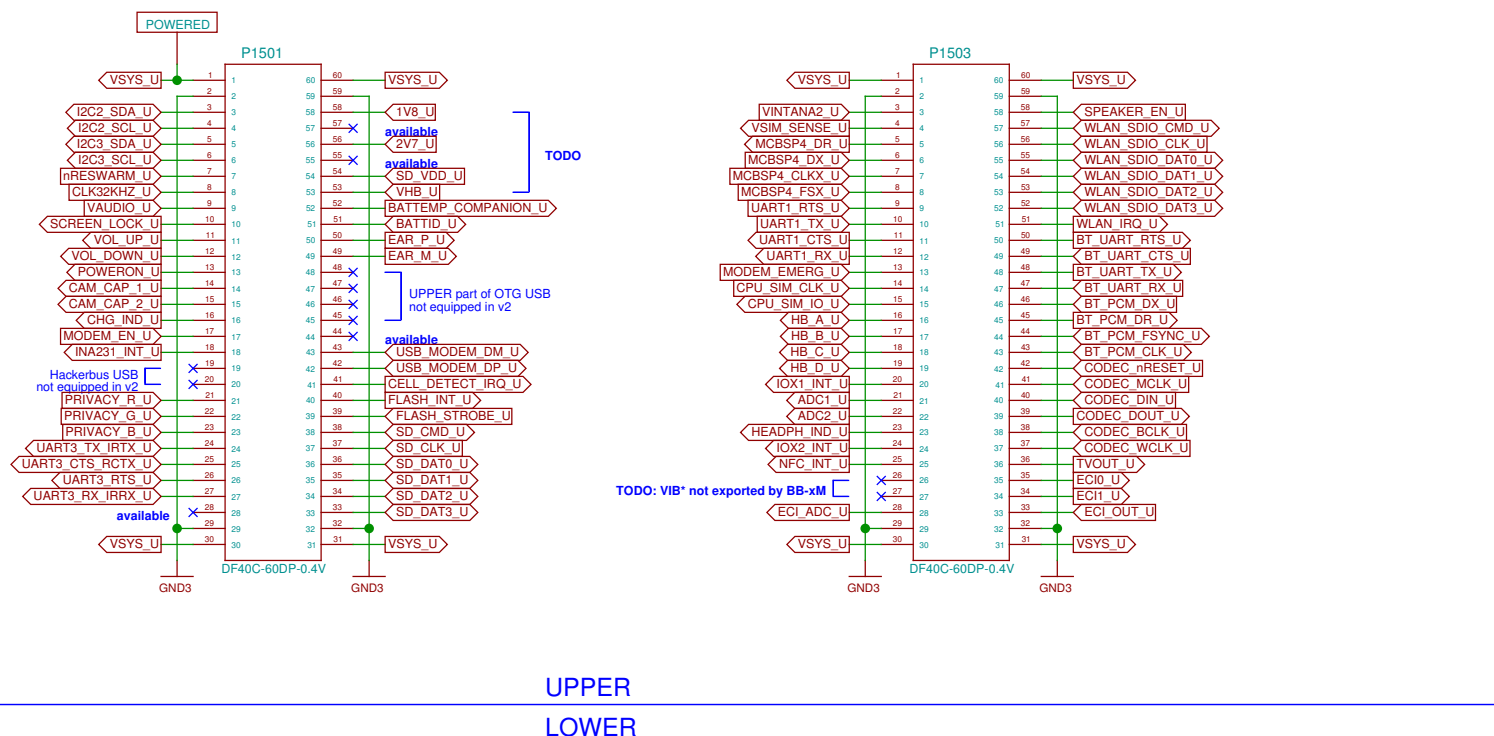

UPPER
LOWER

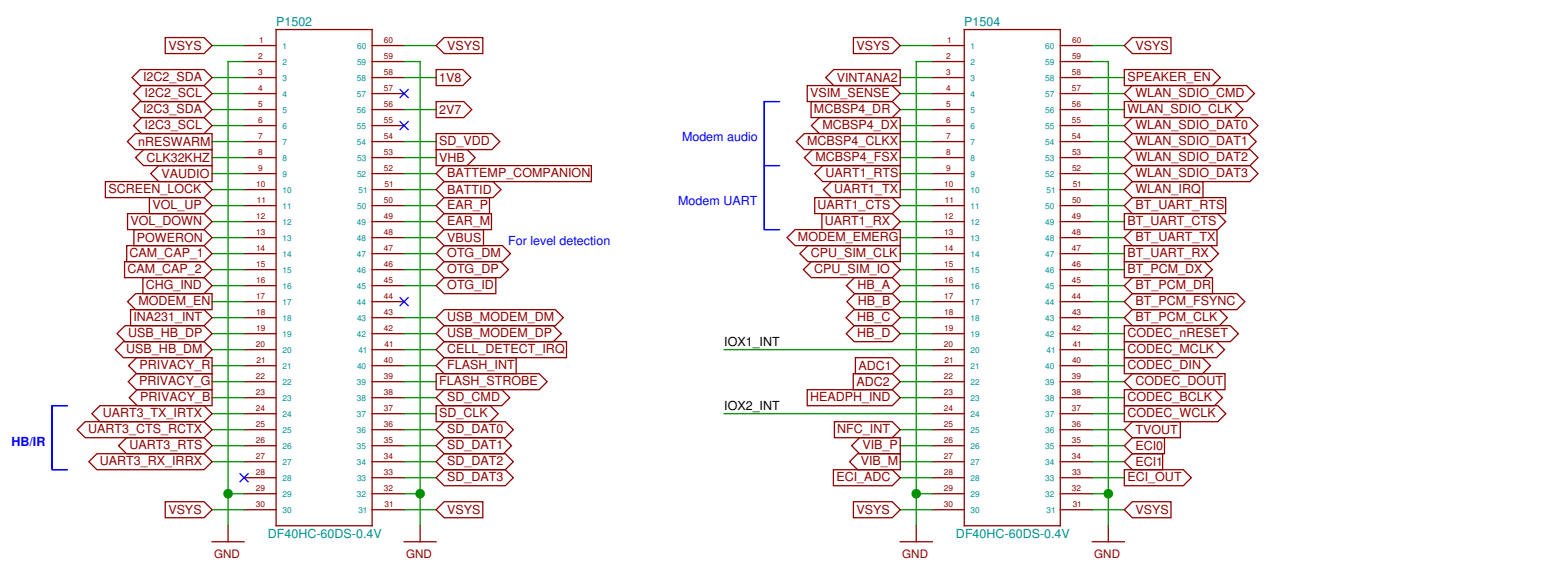

Current rating per contact: 0.3 A

IO expanders (on LOWER)

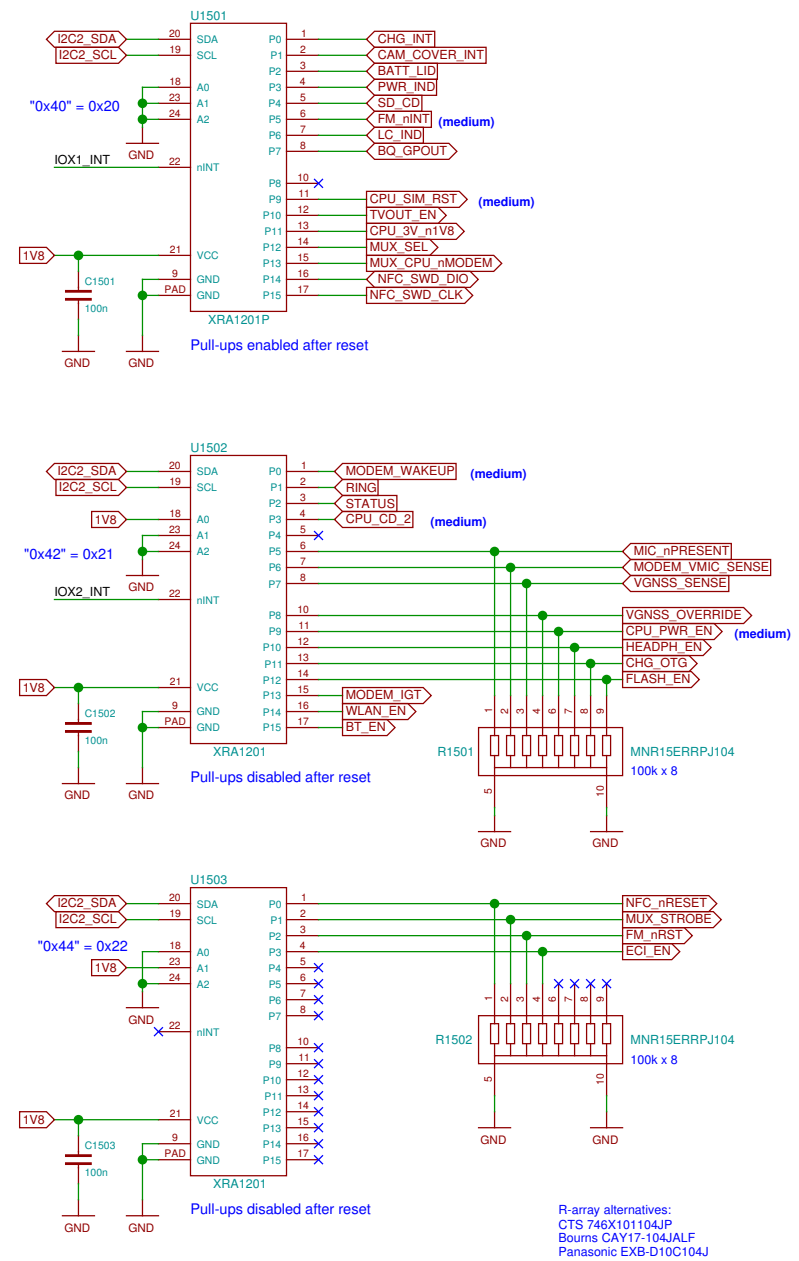

R-array alternatives:
CTS 746X101104JP
Bourns CAY17-104JALF
Panasonic EXB-D10C104J

Sheet: /B2B LOWER-UPPER/ File: b2b.sch	
Title: B2B LOWER-UPPER	
Size: A3	Date: 2016-11-22 10:44:58
Plotted by: eeshow afac499+ 20161129-04:04Z	Rev: Id: 15/25

LOWER-BOB Interconnect (LOWER side)

Defined in the Hackerbus specification, <http://neo900.org/stuff/papers/hb.pdf>

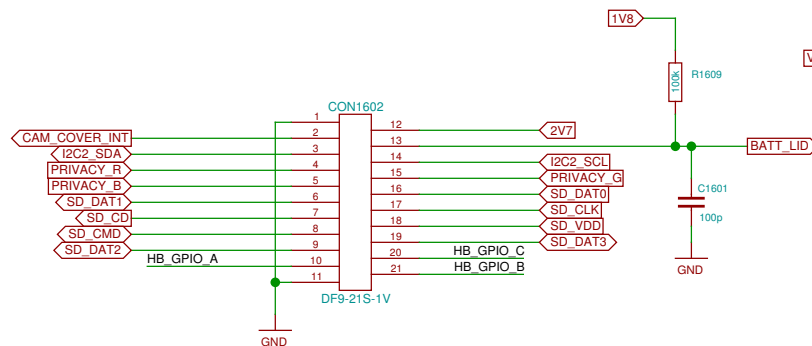
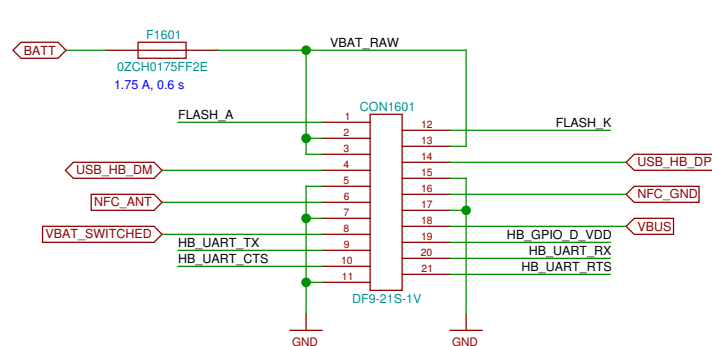

Flash/Torch

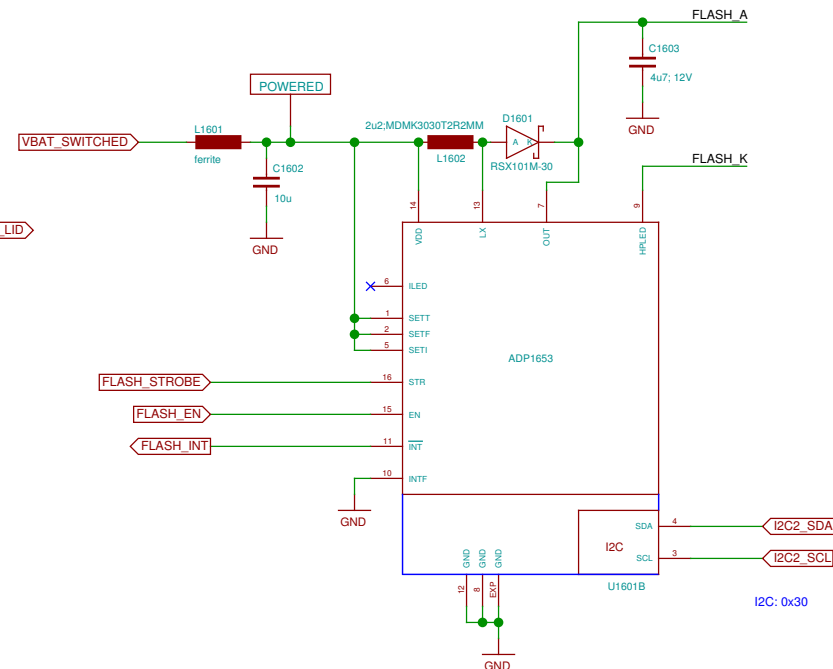

Level shifters for Hackerbus GPIO and UART

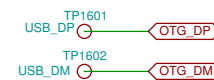
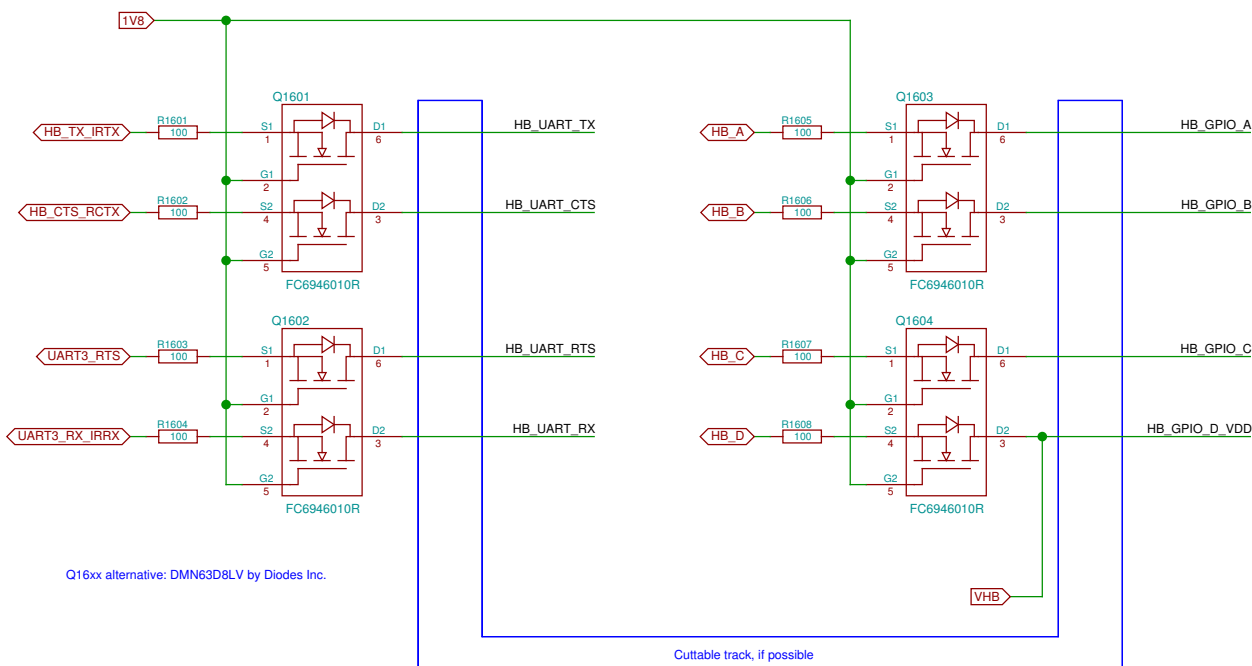

Patch field

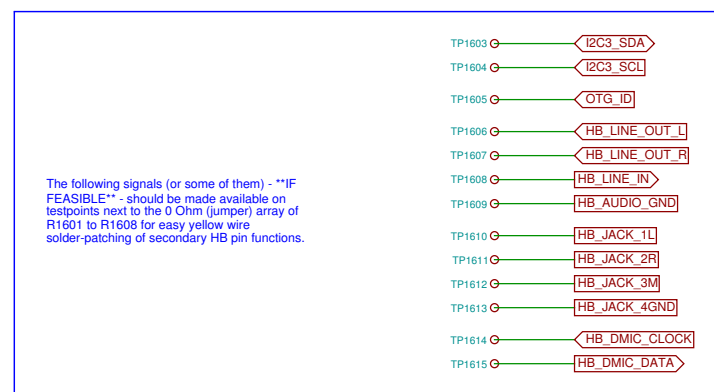

The following signals (or some of them) - **IF FEASIBLE** - should be made available on testpoints next to the 0 Ohm (jumper) array of R1601 to R1608 for easy yellow wire solder-patching of secondary HB pin functions.

Camera Cover detect

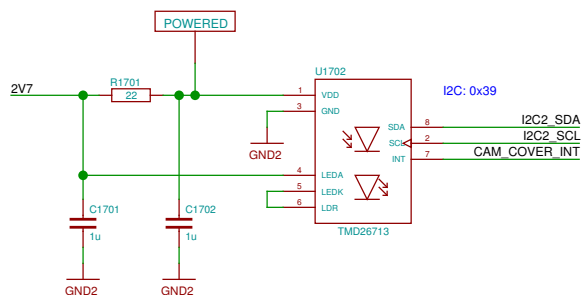

Battery Cover detect

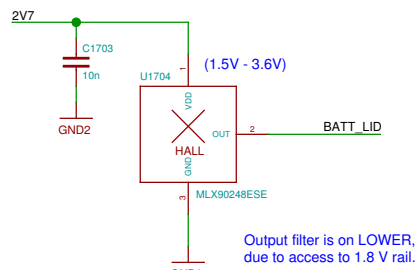

Memory card holder

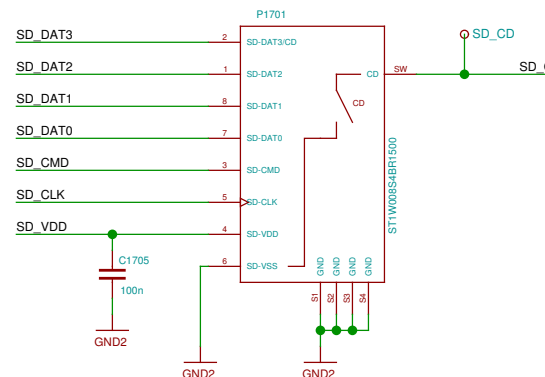

Camera flash

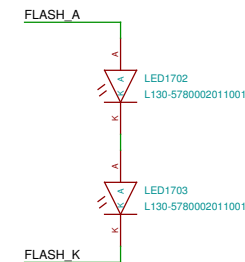

Camera lens plate



Privacy LED

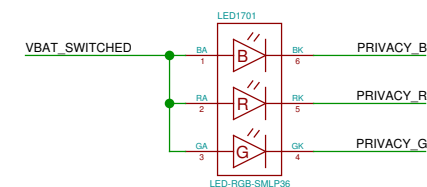

LOWER-BOB Interconnect (BOB side)

Defined in the Hackerbus specification, <http://neo900.org/stuff/papers/hb.pdf>

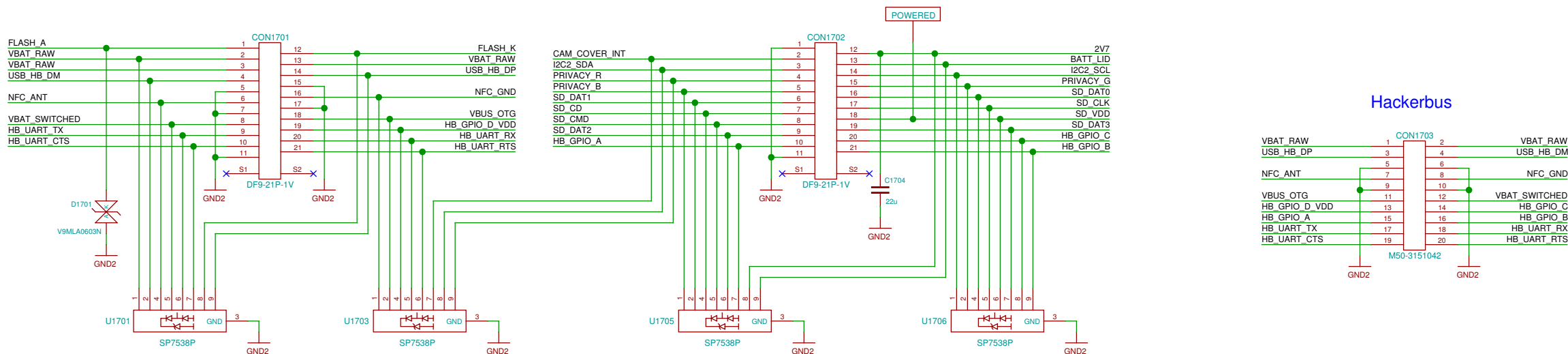

**ESD pin assignment is only indicative.
Actual assignment to be defined by layout.**

Hackerbus

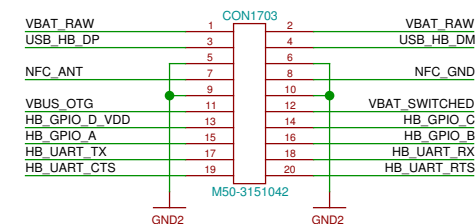

Keyboard matrix

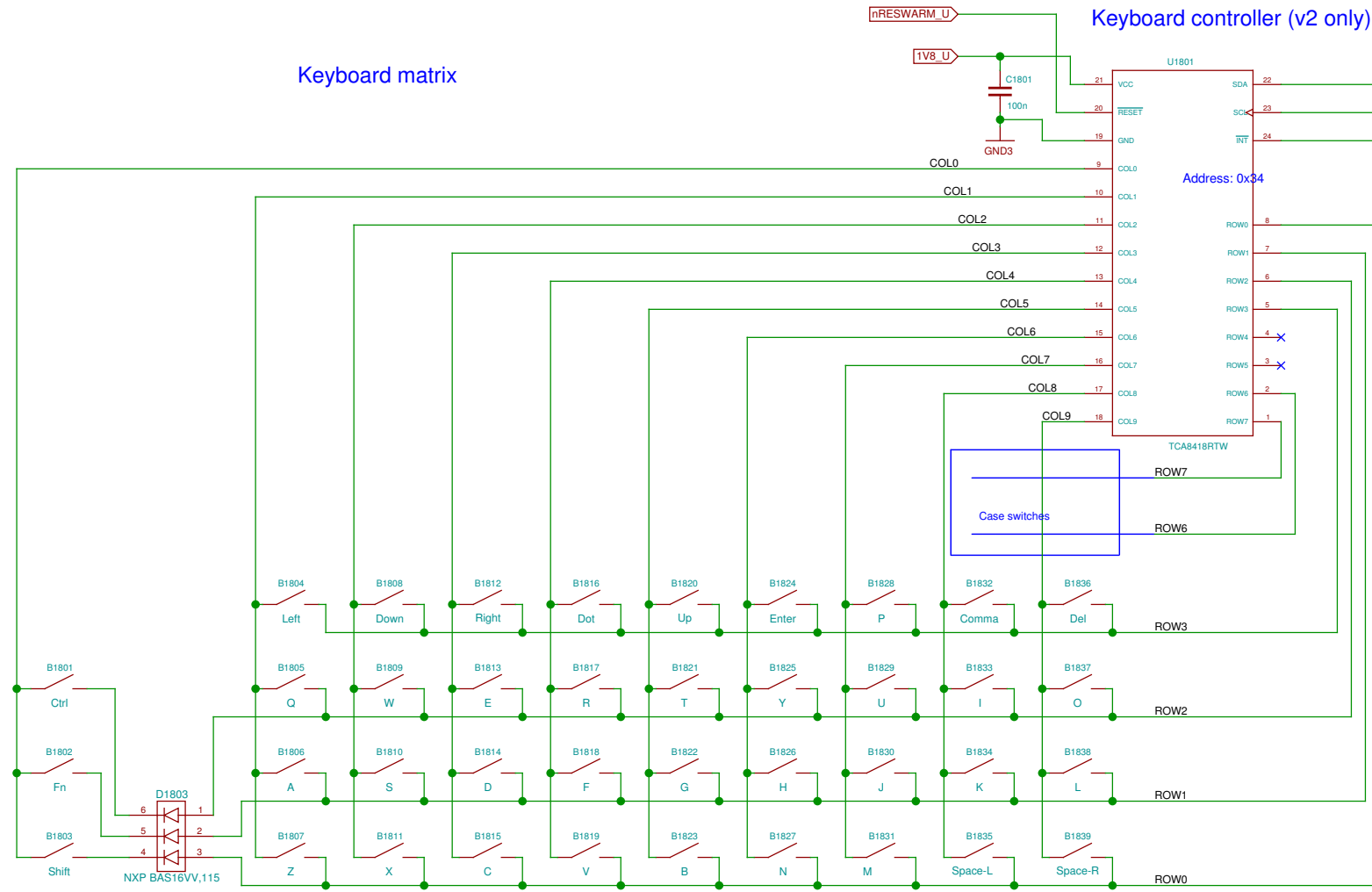

Keyboard controller (v2 only)

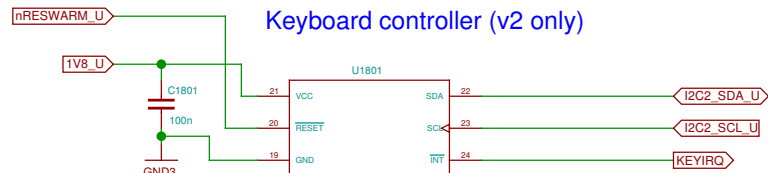

Address: 0x34

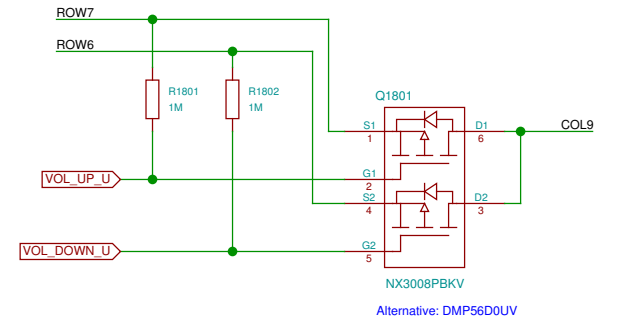

Alternative: Diodes Inc. BAS16VV-7
Warning: Diodes Inc. have cathodes on pin 1 side, NXP anodes !

UPPER
LOWER

Volume

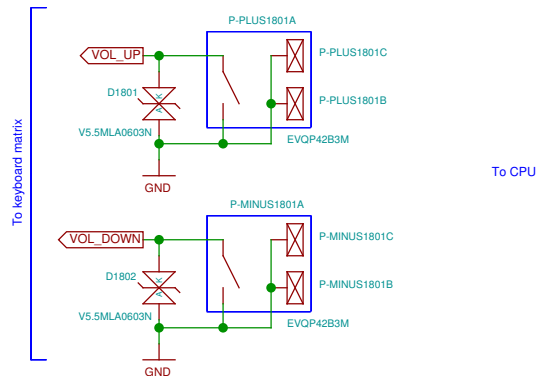

Camera trigger

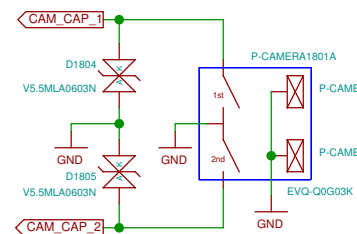

To companion chip

On-off

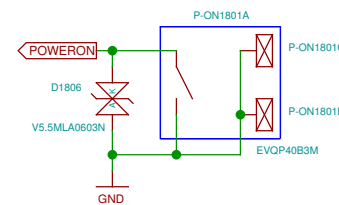

To CPU

Lock switch

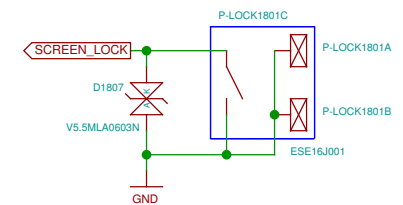

Sheet: /Keypad and buttons/
File: keys.sch

Title: Keypad and buttons

Size: A3 Date: 2016-11-18 15:48:54

Rev: Id: 18/25

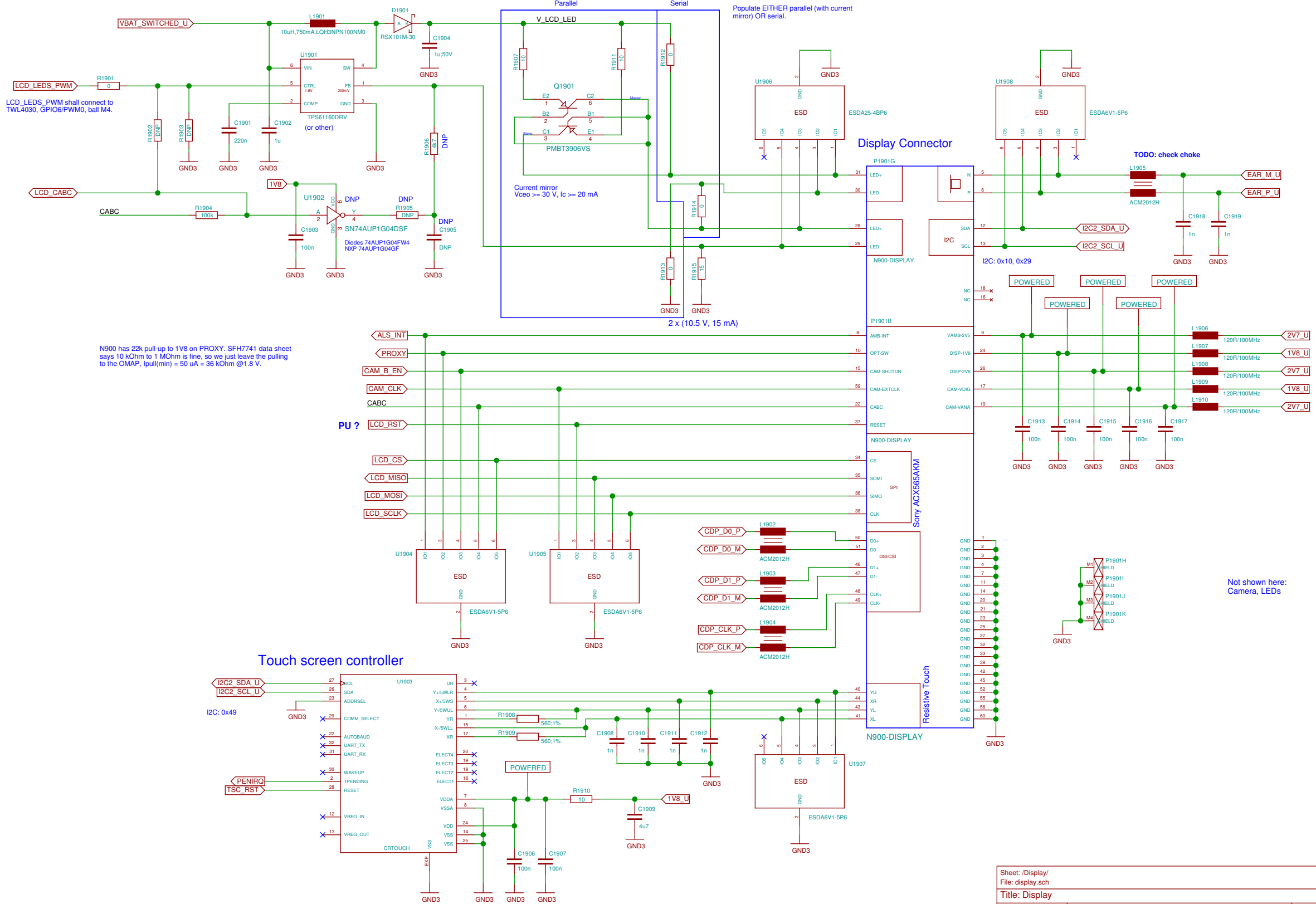

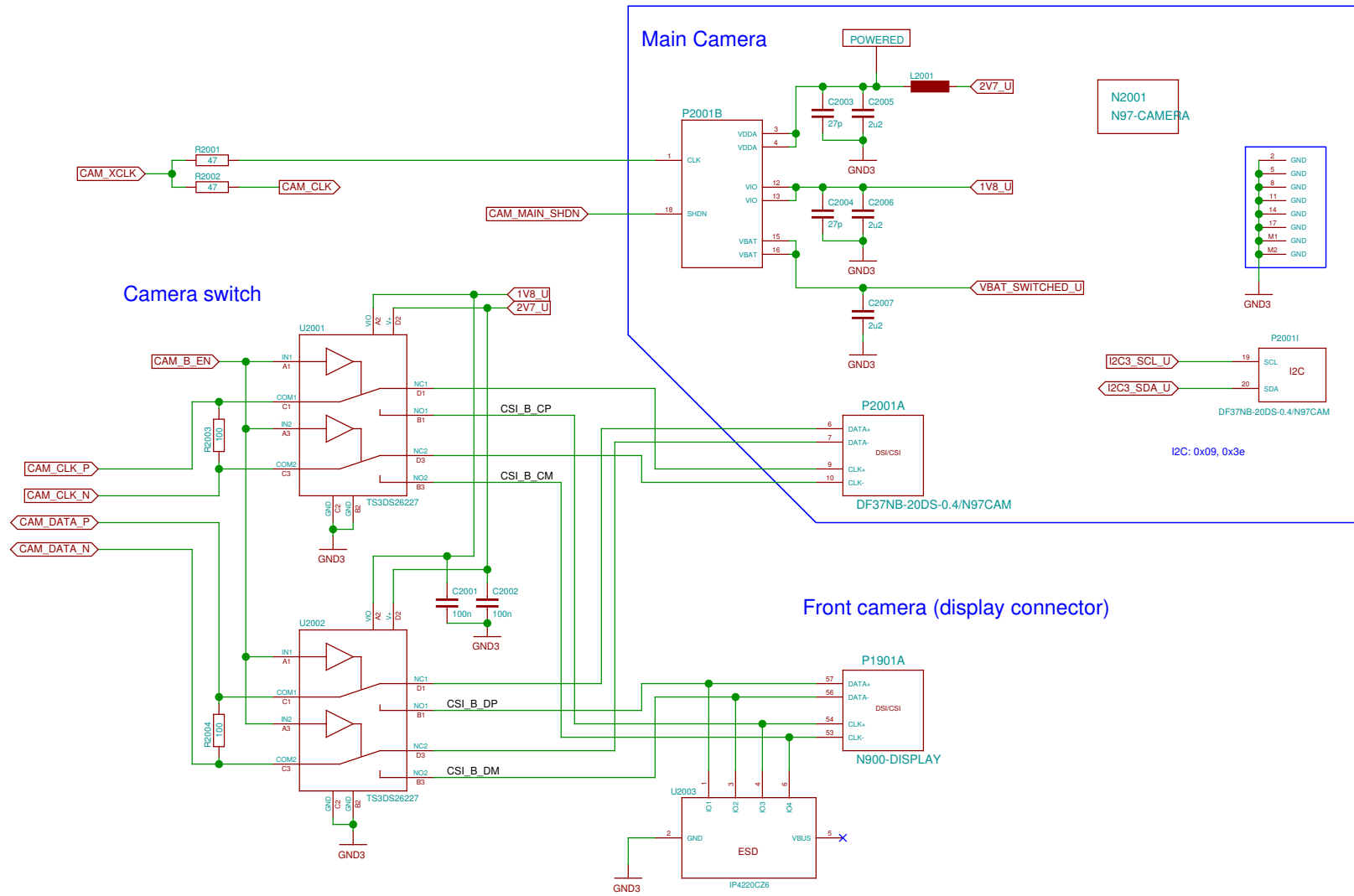

Basic LED controllers

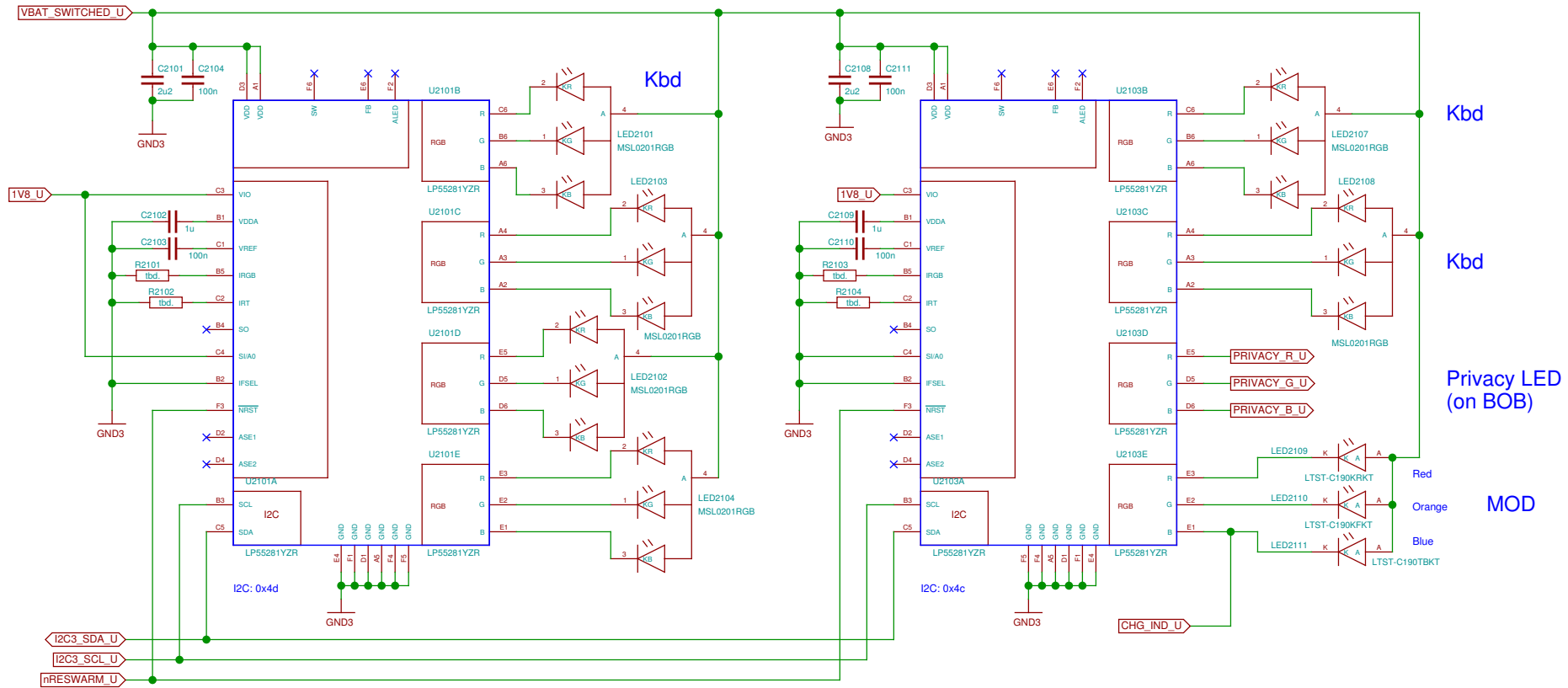

Fancy LED controller

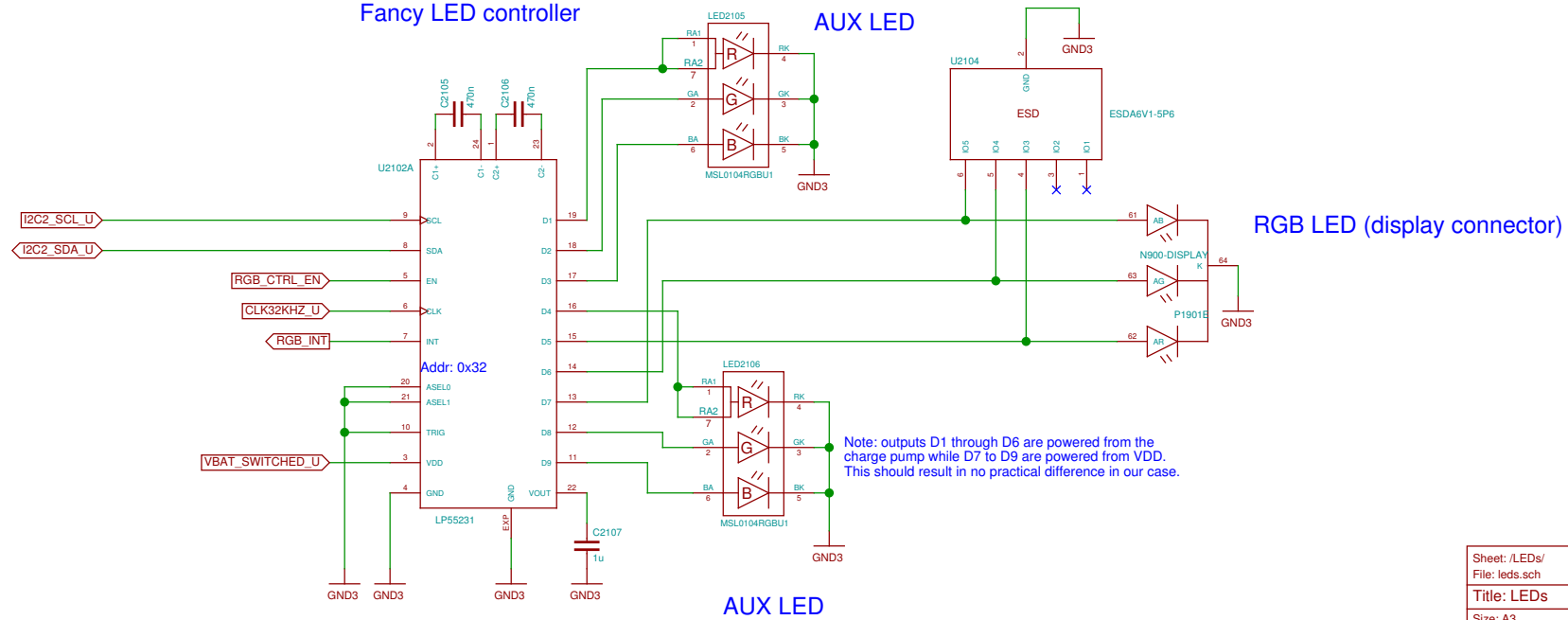

Sheet: /LEDs/		Date: 2016-11-23 22:26:52	
File: leds.sch		Rev:	
Title: LEDs			
Size: A3	Date: 2016-11-23 22:26:52		Rev:
Plotted by eeshow afac499+ 20161129-04:04Z			Id: 21/25

simple capless 400mA LDO for TPS65950 substitute
(only for prototype)

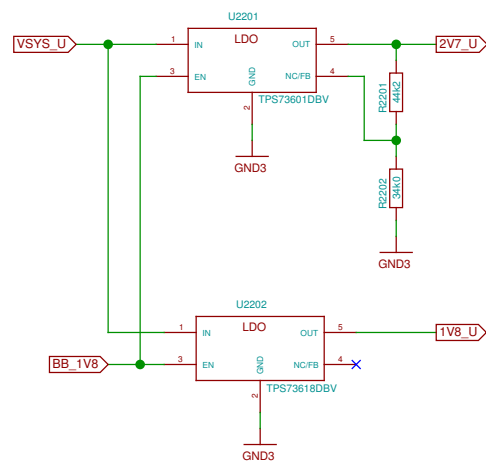

TODO: use REGEN ?

Modem USB

connect to BB
by some Micro-USB cable

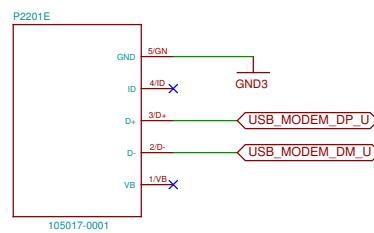

32 kHz clock

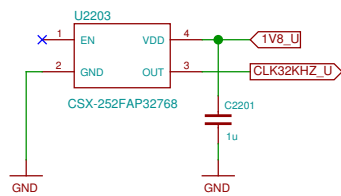

Alternative: OYKTGLJANF-0.032768

19.2 MHz clock

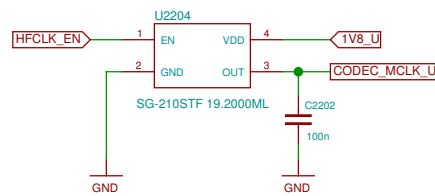

Alternative: KC2520B19.2000C1GE00

Sheet: /Adaptation (v2 only)/		
File: v2.sch		
Title: Adaptation (v2 only)		
Size: A3	Date: 2016-11-18 15:49:26	Rev:
Plotted by eeshow afac499+ 20161129-04:04Z		Id: 22/25

BB-xM Main Expansion Header (P9, 7.24)

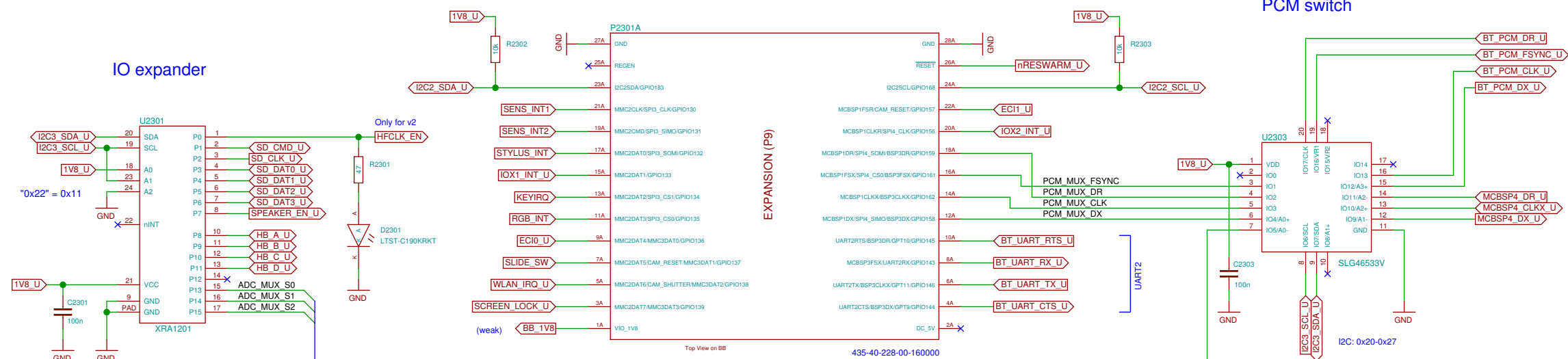

Same part, as "breakaway" strip (72 positions):
435-40-272-00-160000

Auxiliary Expansion Header (P17, 7.26)

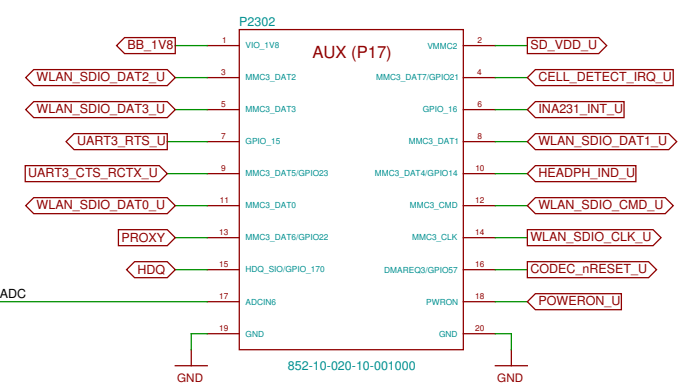

Same part, as "breakaway" strip (100 positions):
852-10-1000-10-001000

ADC multiplexer

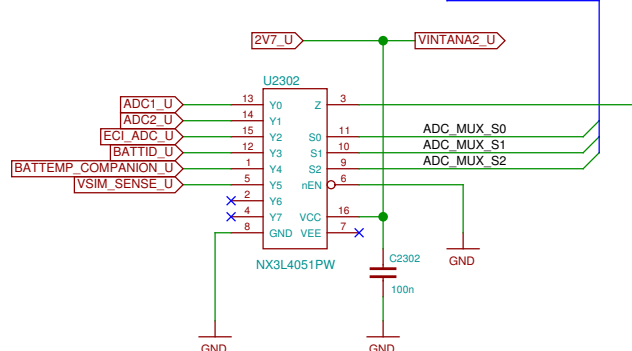

No UART3_RTS on BB-xM, using GPIO
No UART3_CTS on BB-xM, using GPIO

FM_nINT (on IO expander)

P11 (7.25)

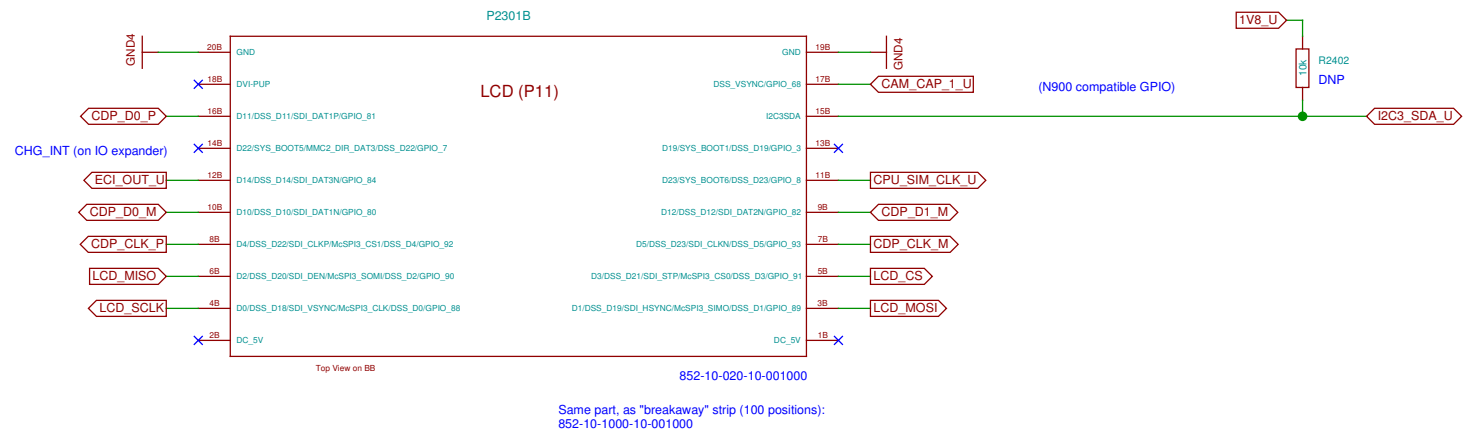

P13 (7.25)

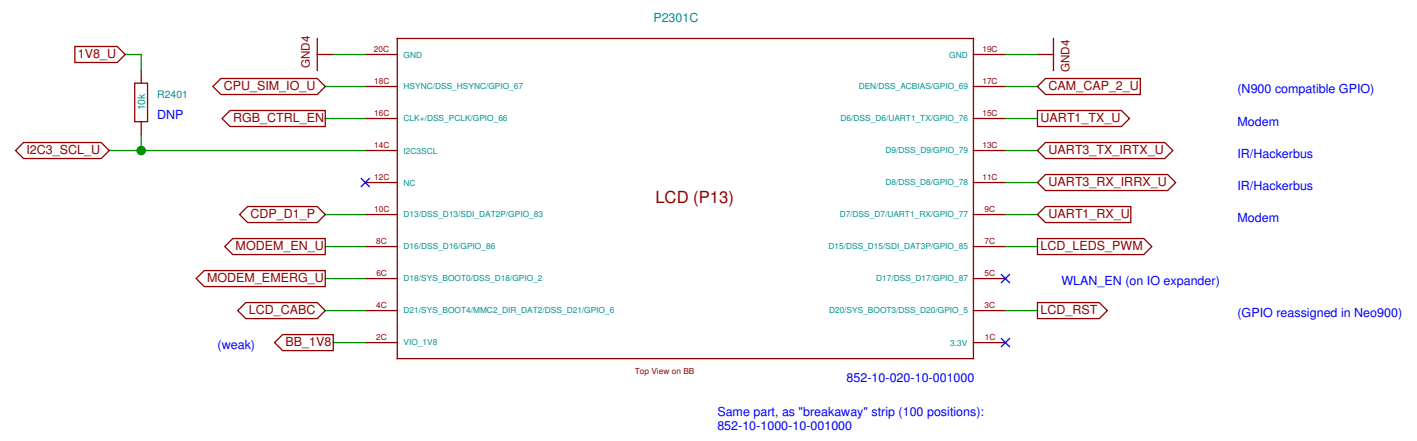

P4 (7.19)

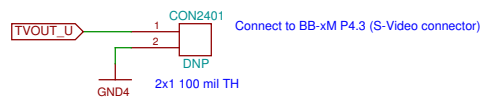

Processor Camera Port Interface (P10, 7.20.3)

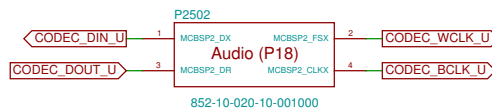
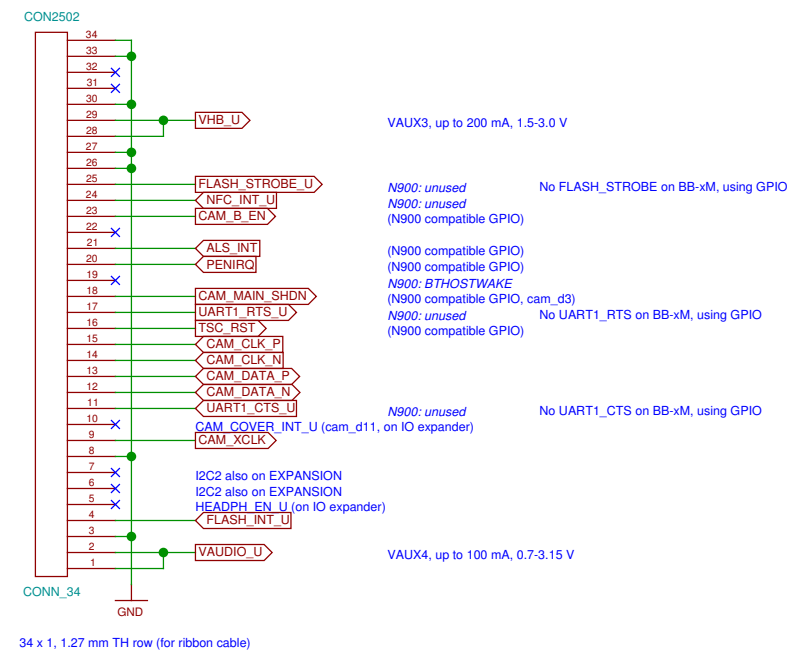
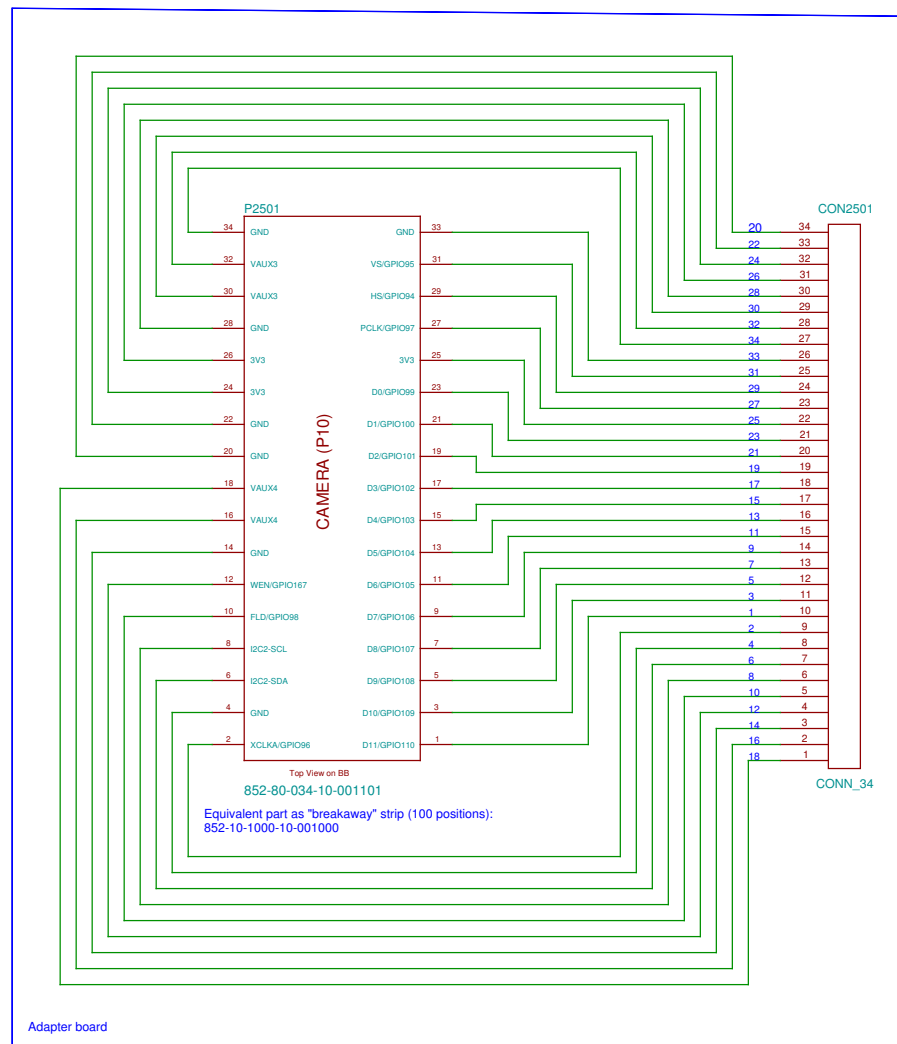

This part is a "breakaway" strip (20 positions) and needs to be customized (cut) before assembly. Alternatively, 852-10-100-10-001000 (100 positions) could be used.