

place in scan matrix? would need 3-4 wires to UPPER board instead of 2!
 No. VOL+ or VOL- can either be connected to GPIOs
 or drive two FETs that sit in the keyboard matrix
 in any case it is sufficient to connect GPIO-VOL+ and VOL- to two pins on the B2B connector

Buttons

TITLE: sedtest

Document Number:

REV:
V2b

Date: 09.09.15 04:52

Sheet: 1/35

can be used to test/operate the modem through the OTG port (w/o UPPER PCB)

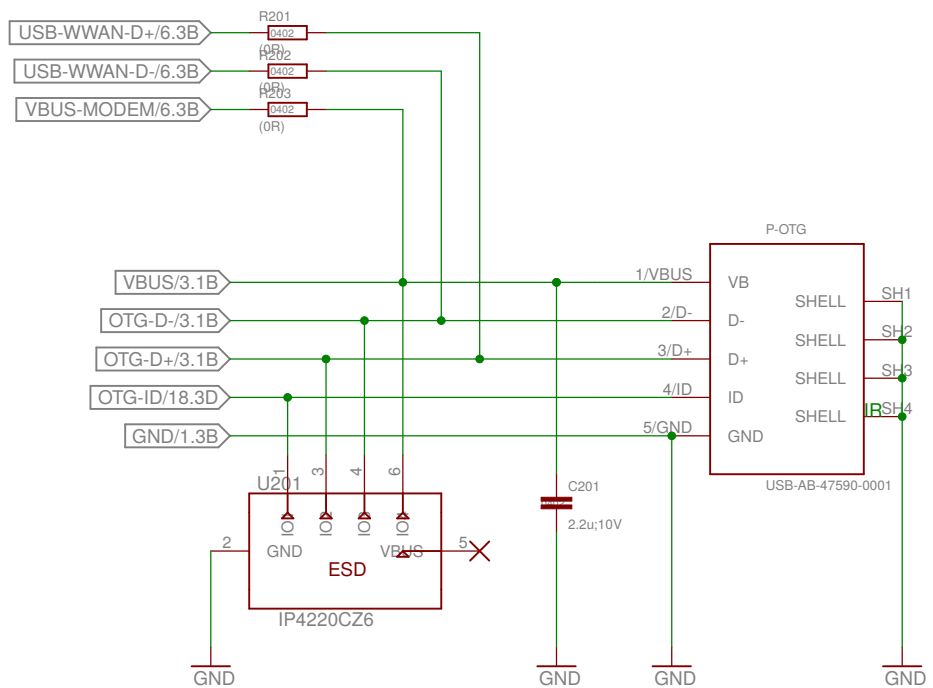

OTG

TITLE: sedtest

Document Number:

REV:
V2b

Date: 09.09.15 04:52

Sheet: 2/35

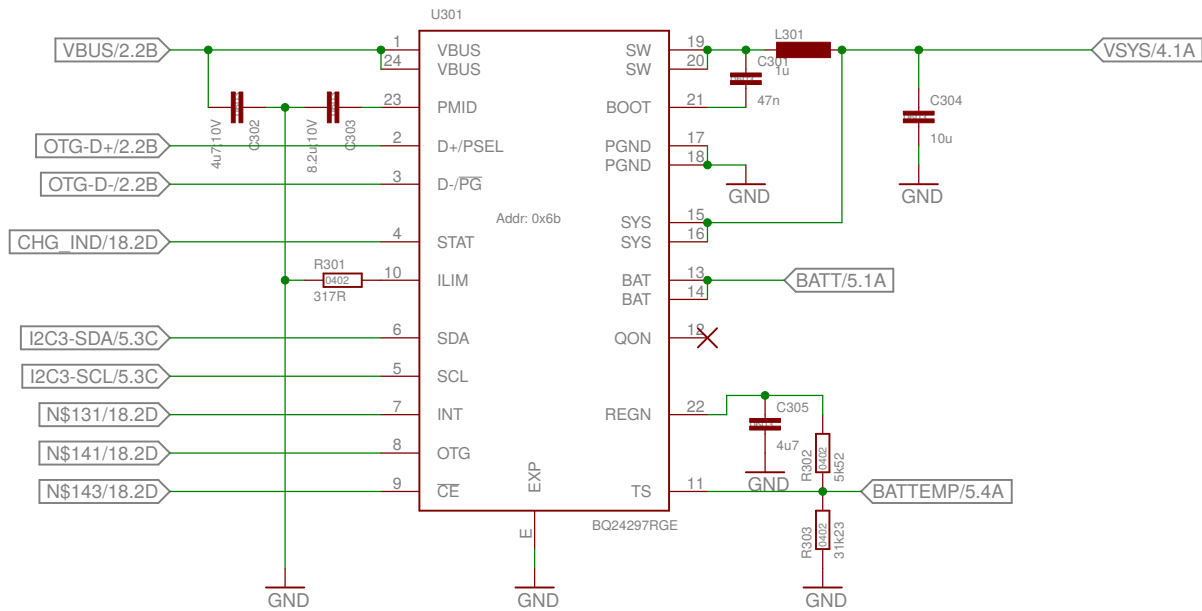

Charger/OTG-Booster

TITLE: sedtest

Document Number:

REV:
V2b

Date: 09.09.15 04:52

Sheet: 3/35

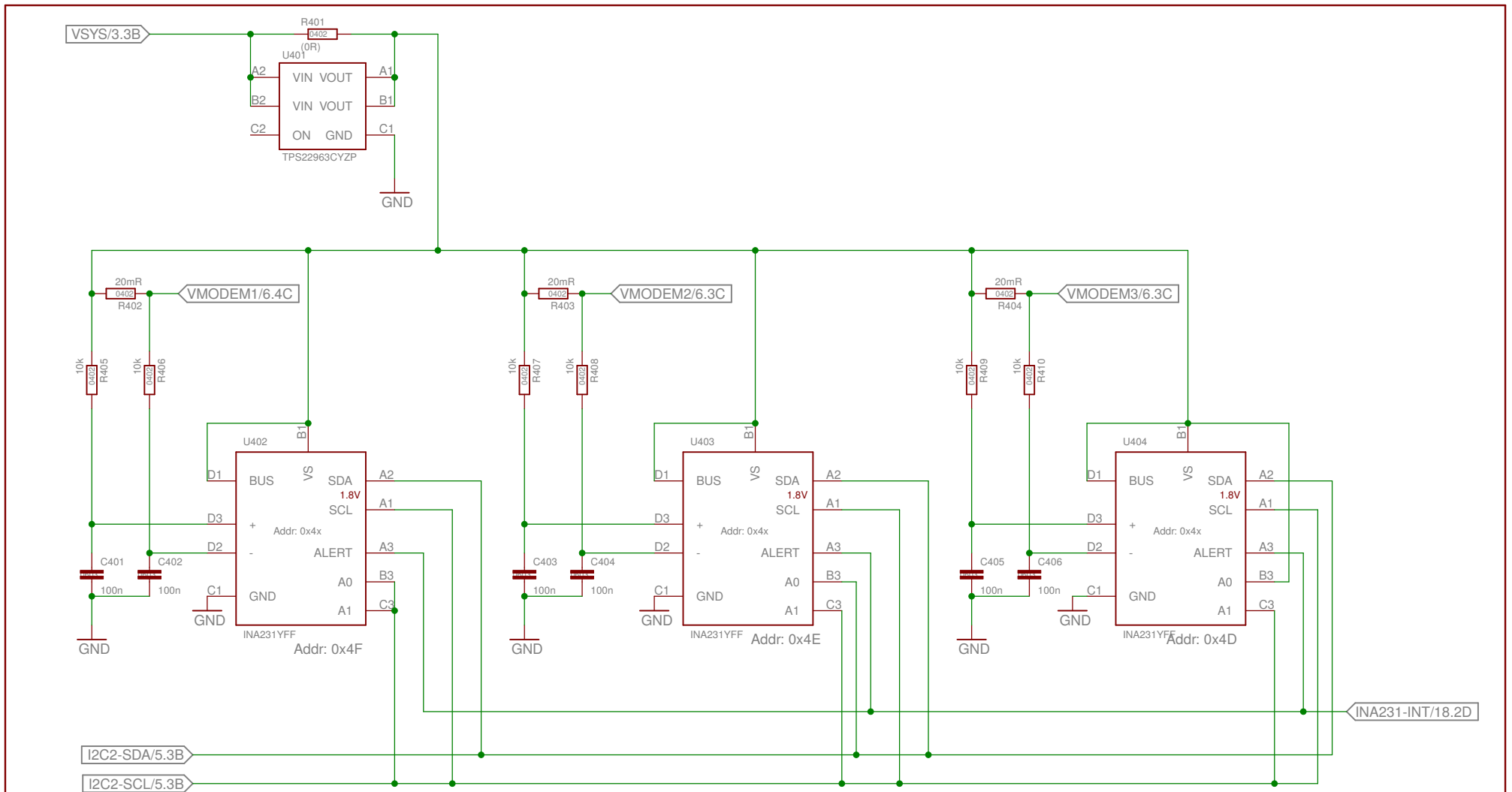

Modem Power

TITLE: sedtest

Document Number:

REV:
V2b

Date: 09.09.15 04:52

Sheet: 4/35

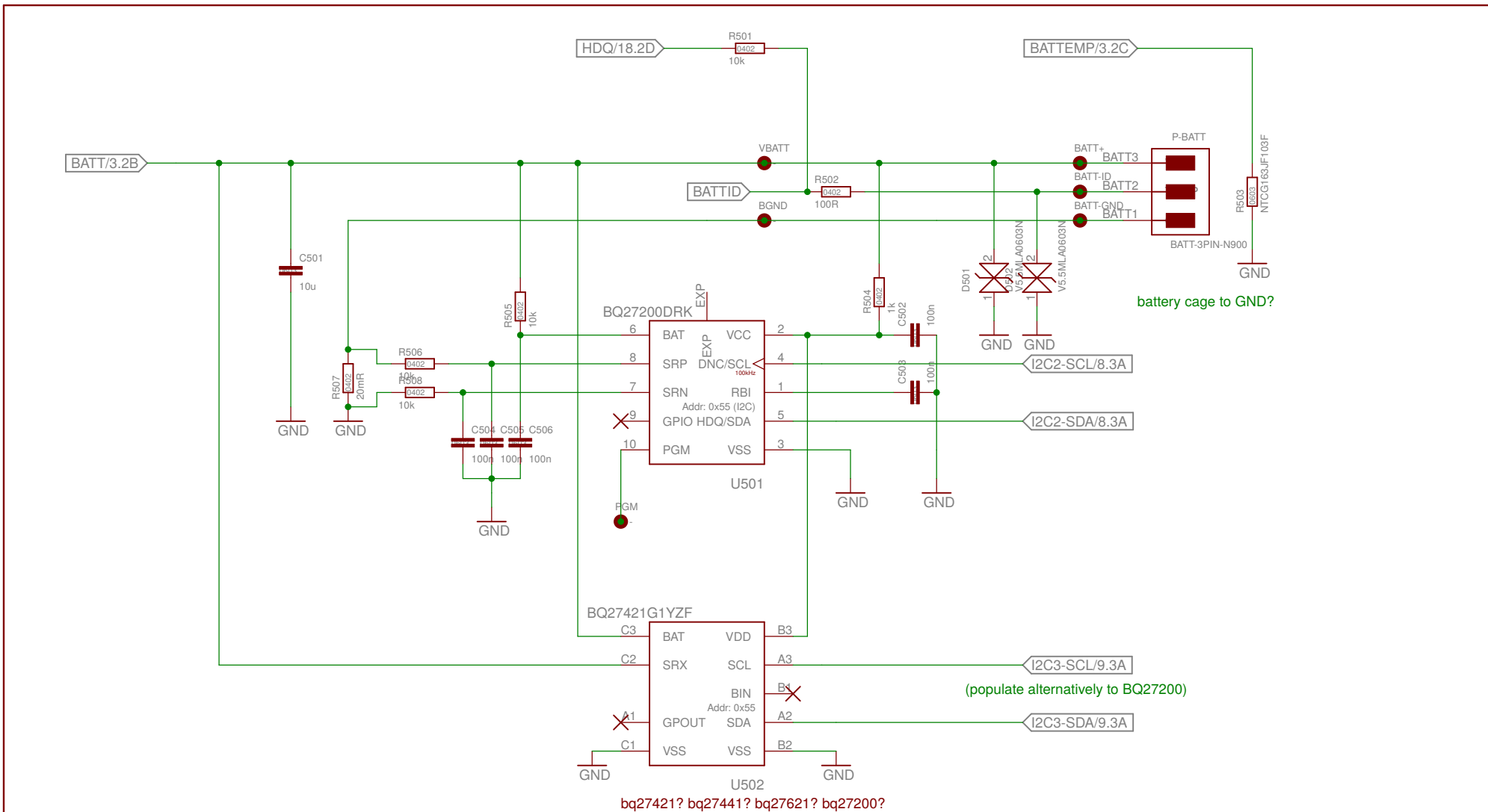

Fuel Gauge

TITLE: sedtest

Document Number:

REV:
V2b

Date: 09.09.15 04:52

Sheet: 5/35

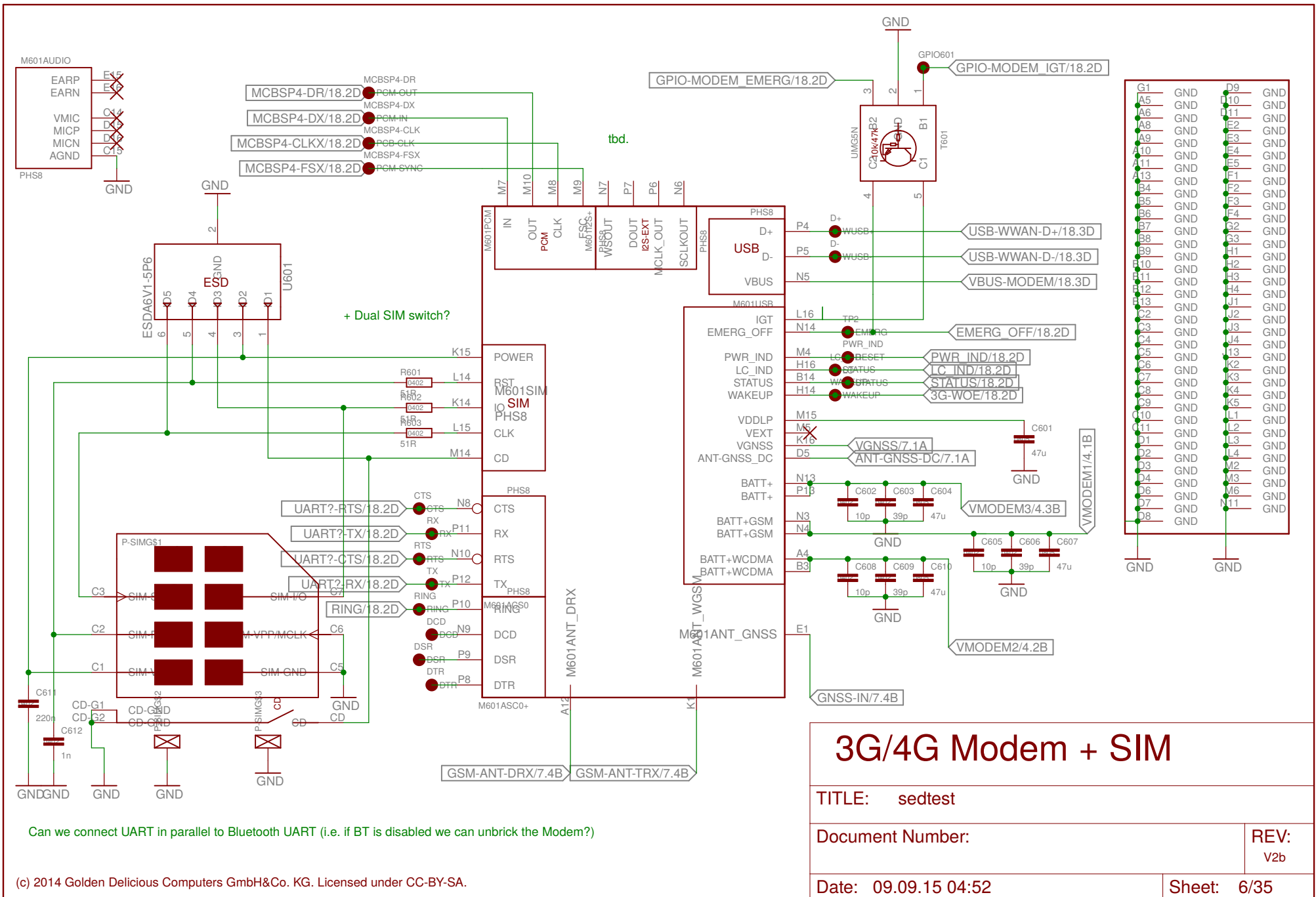

Can we connect UART in parallel to Bluetooth UART (i.e. if BT is disabled we can unbrick the Modem?)

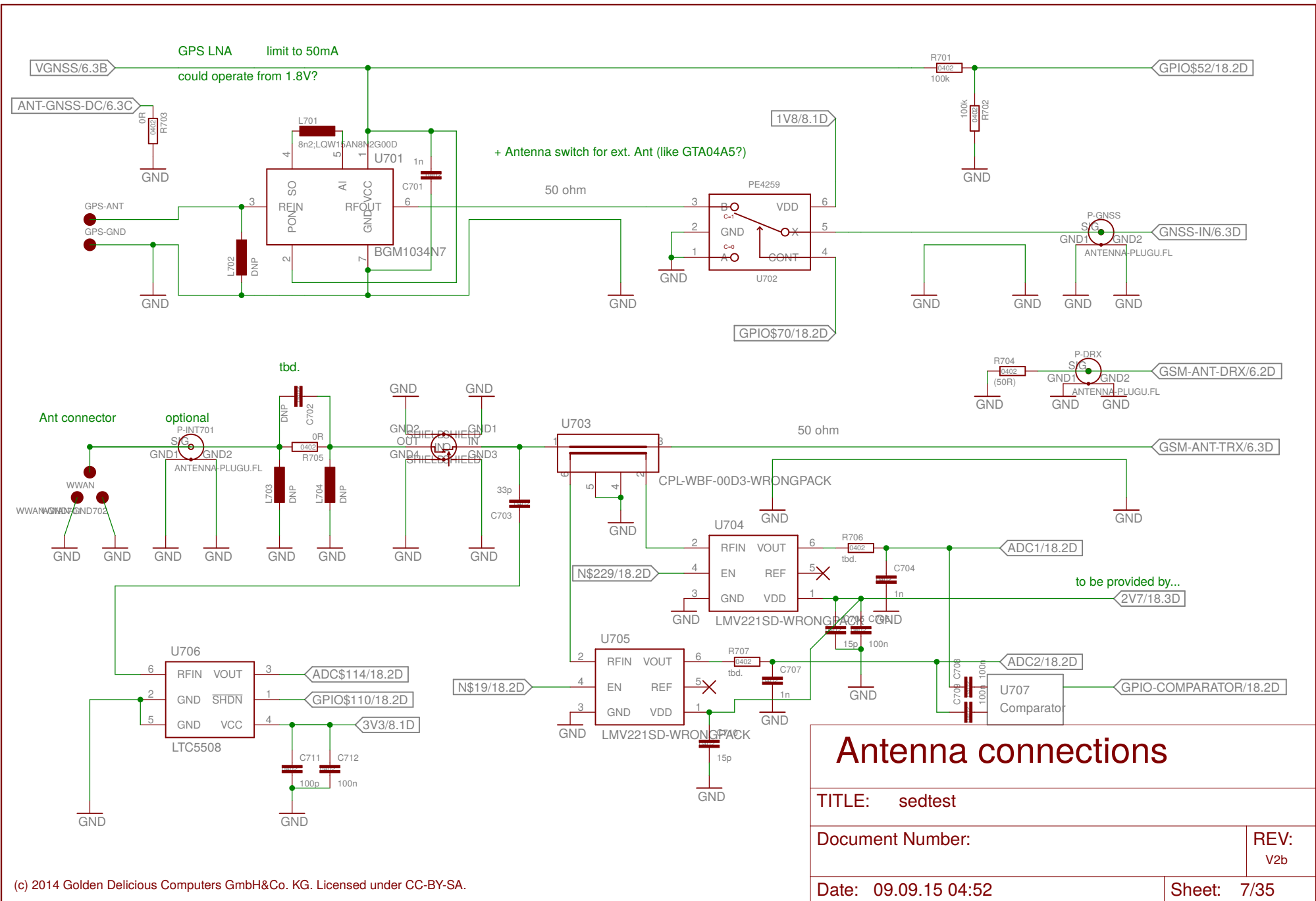

Antenna connections

TITLE: sedtest	
Document Number:	REV: V2b
Date: 09.09.15 04:52	Sheet: 7/35

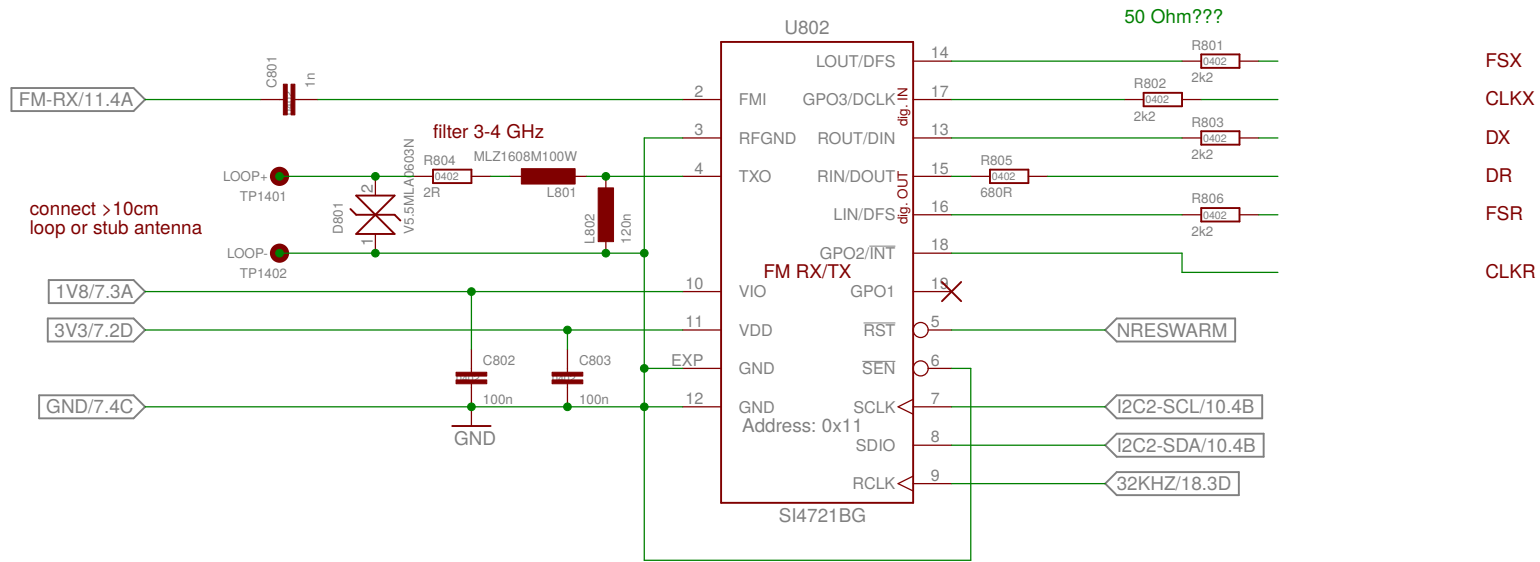

Si4705 is pin compatible (mostly) but RX-only

WiLink5

Dämpfungs-RC's?

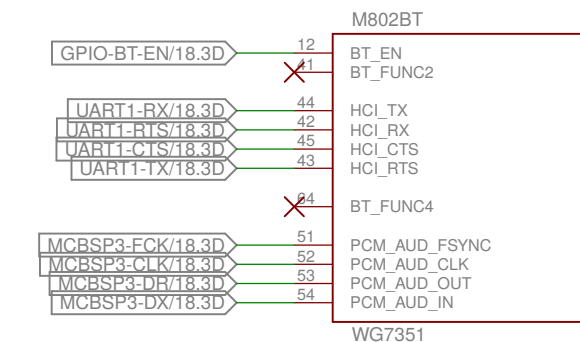
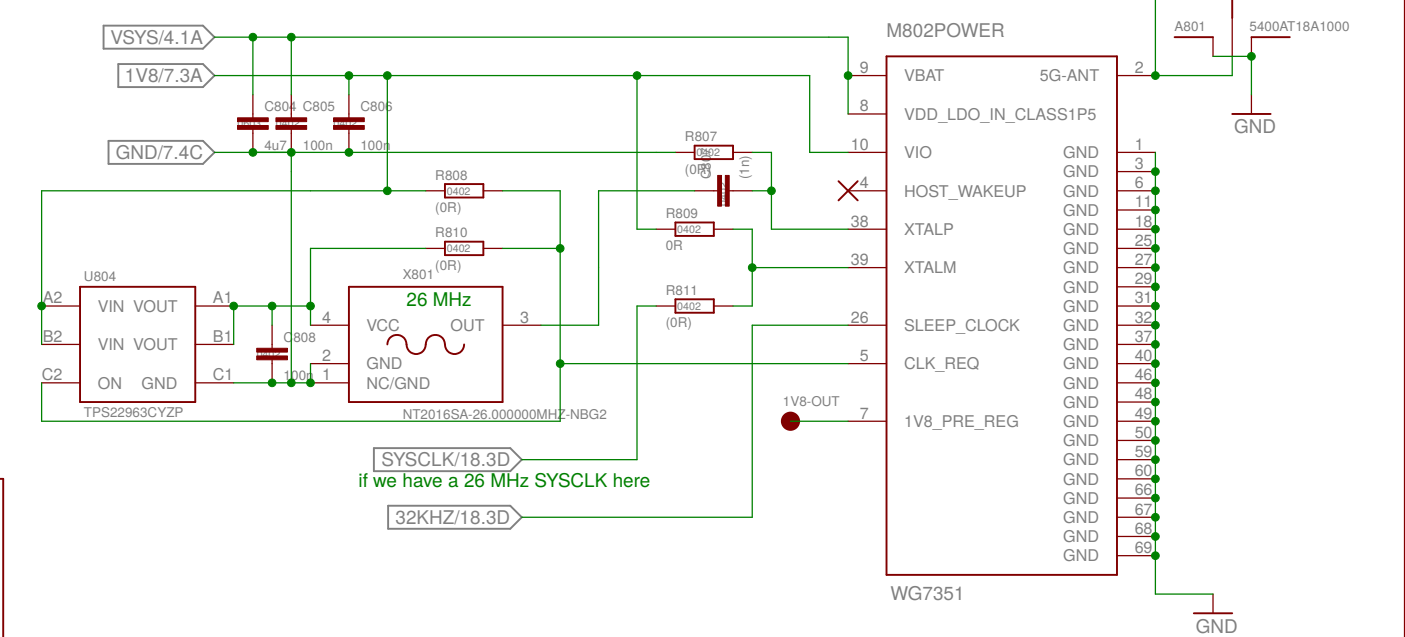
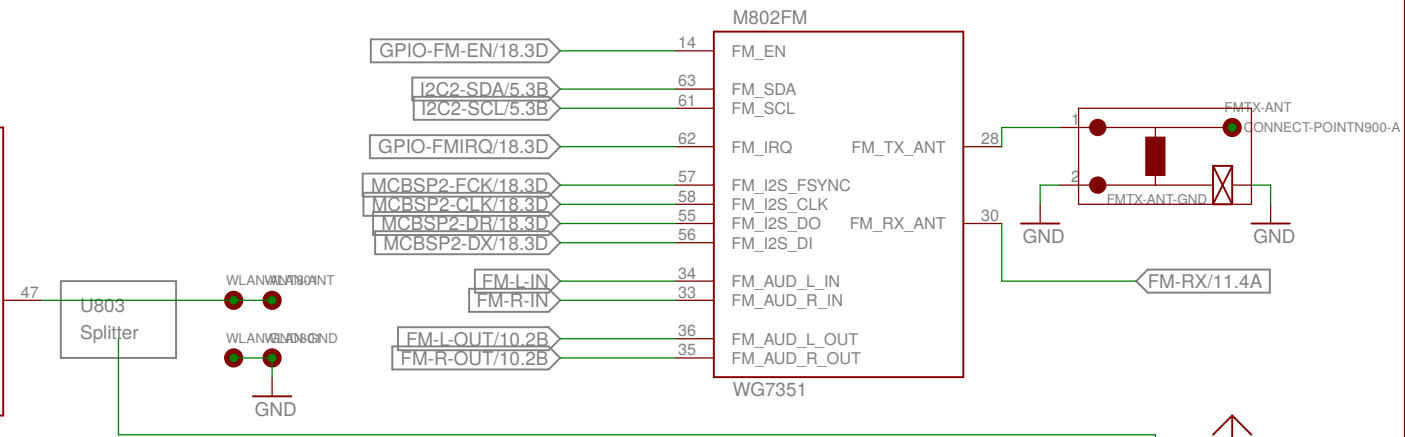
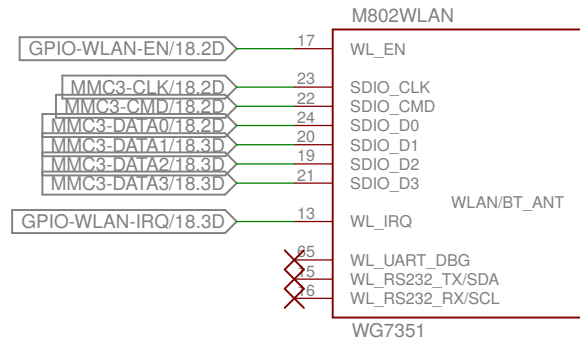

WLAN & Bluetooth & FM

TITLE: sedtest	
Document Number:	REV: V2b
Date: 09.09.15 04:52	Sheet: 8/35

WiLink8

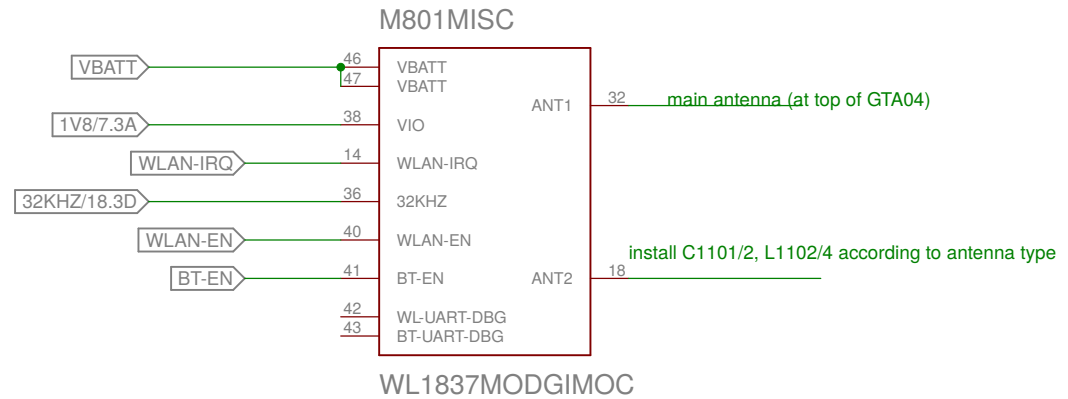
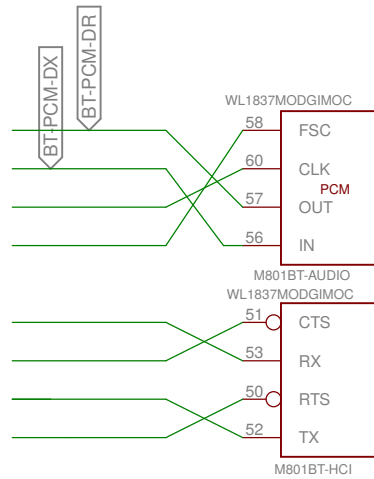

secondary (on the side of GTA04)
could be 5.8GHz as well

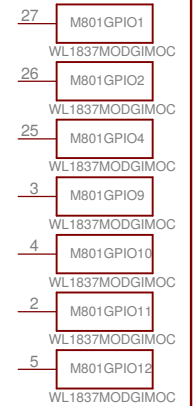
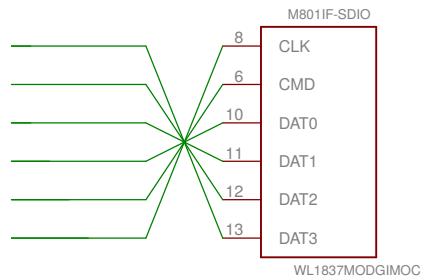

WLAN & Bluetooth & FM

TITLE: sedtest

Document Number:

REV:
V2b

WiLink6

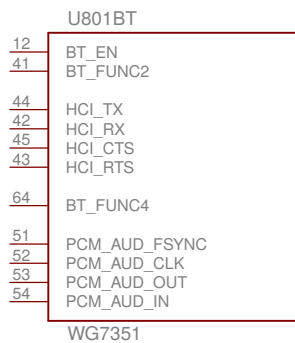
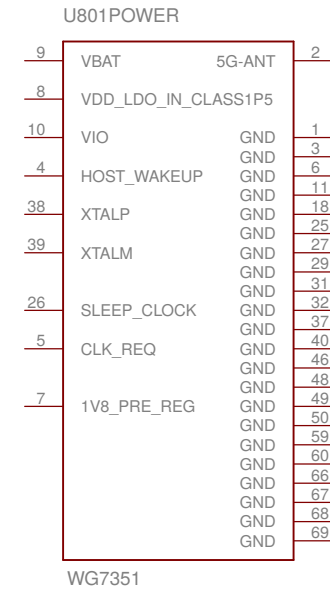
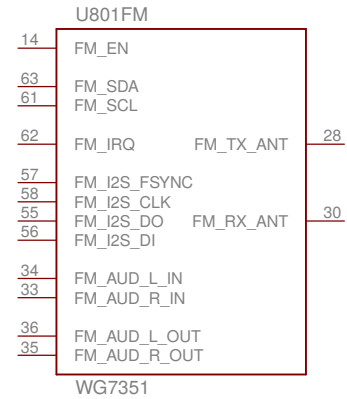
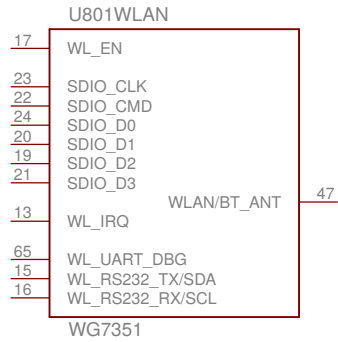

WLAN & Bluetooth & FM

TITLE: sedtest

Document Number:

REV:
V2b

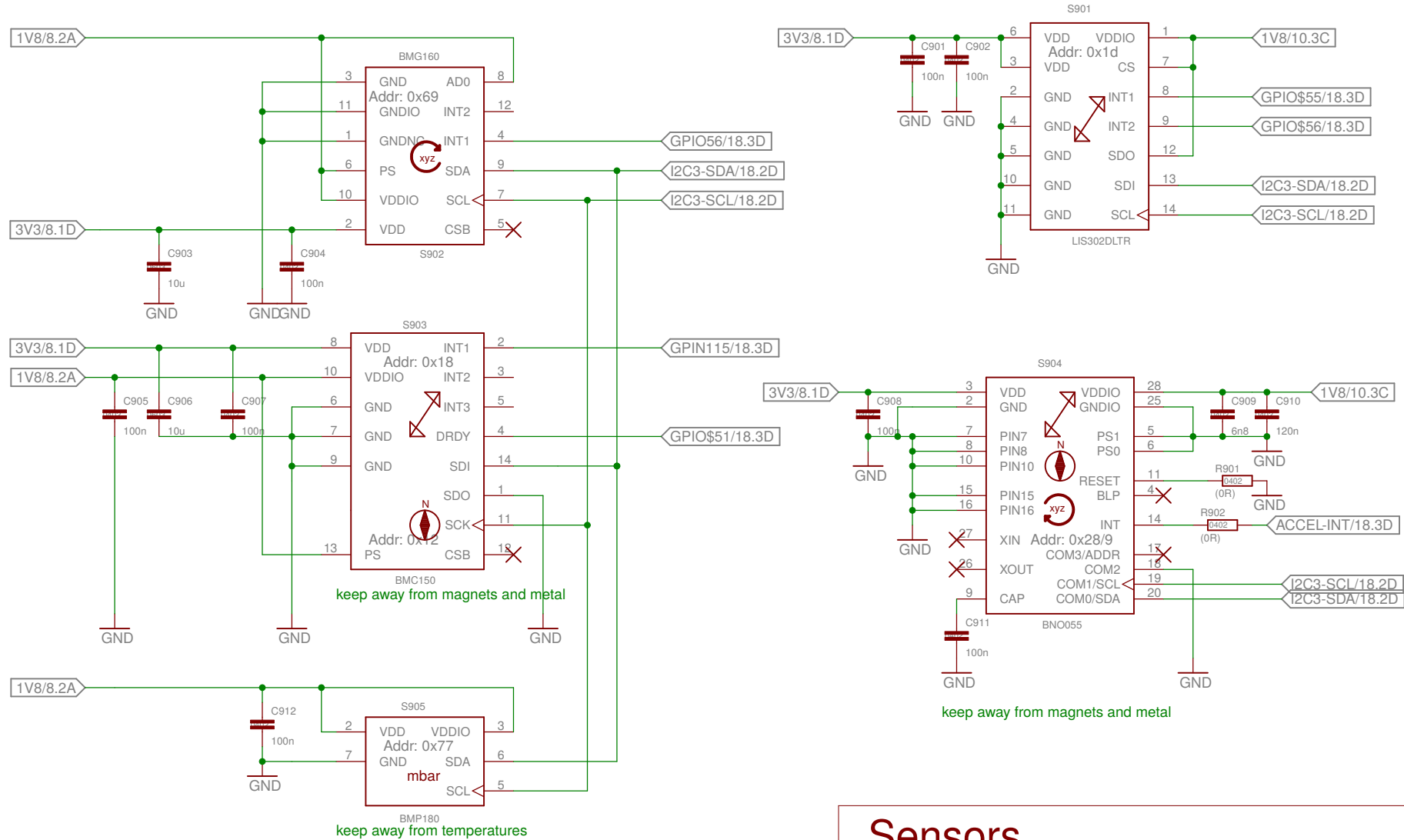

Sensors

TITLE: sedtest

Document Number:

REV:
V2b

Date: 09.09.15 04:52

Sheet: 9/35

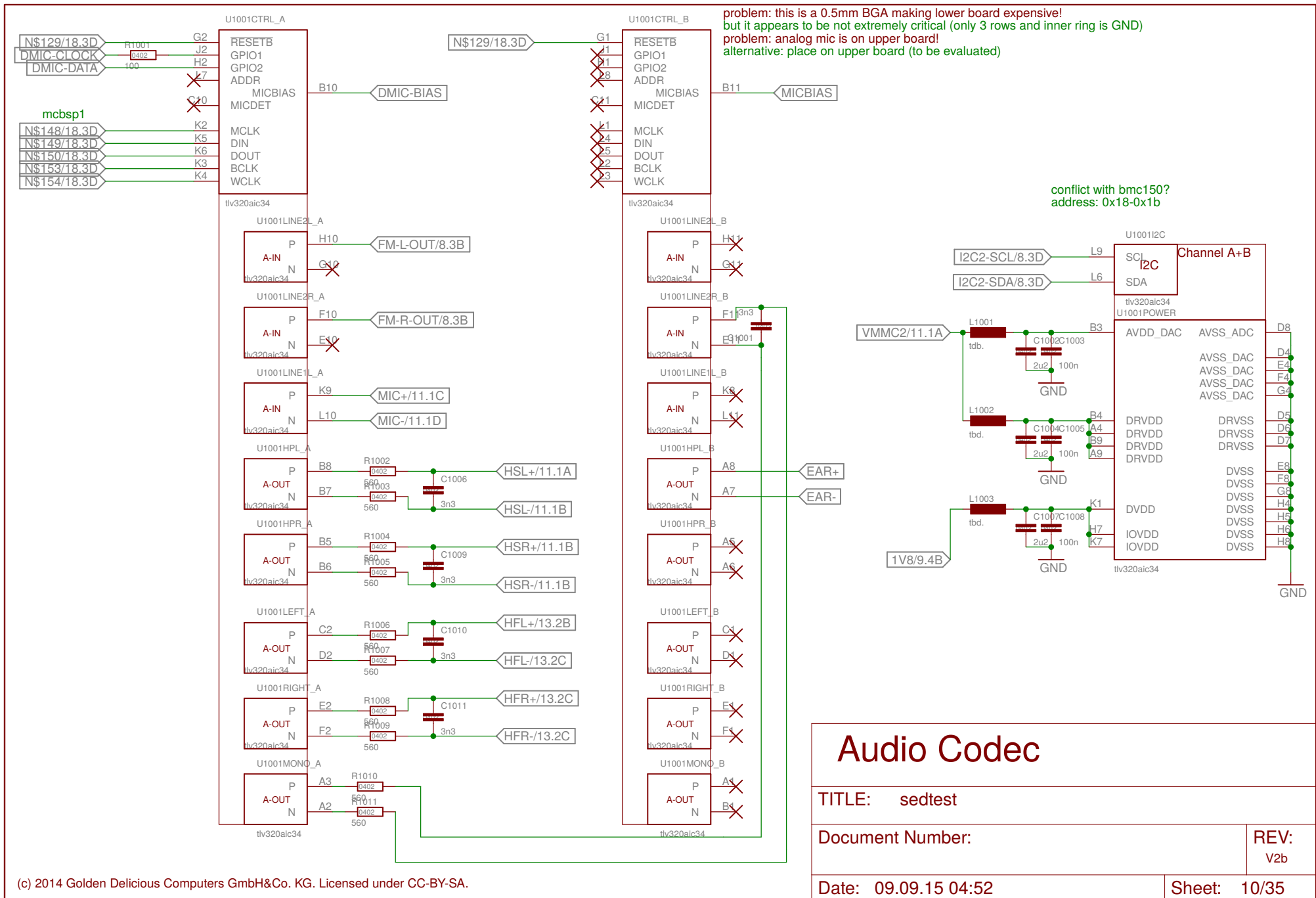

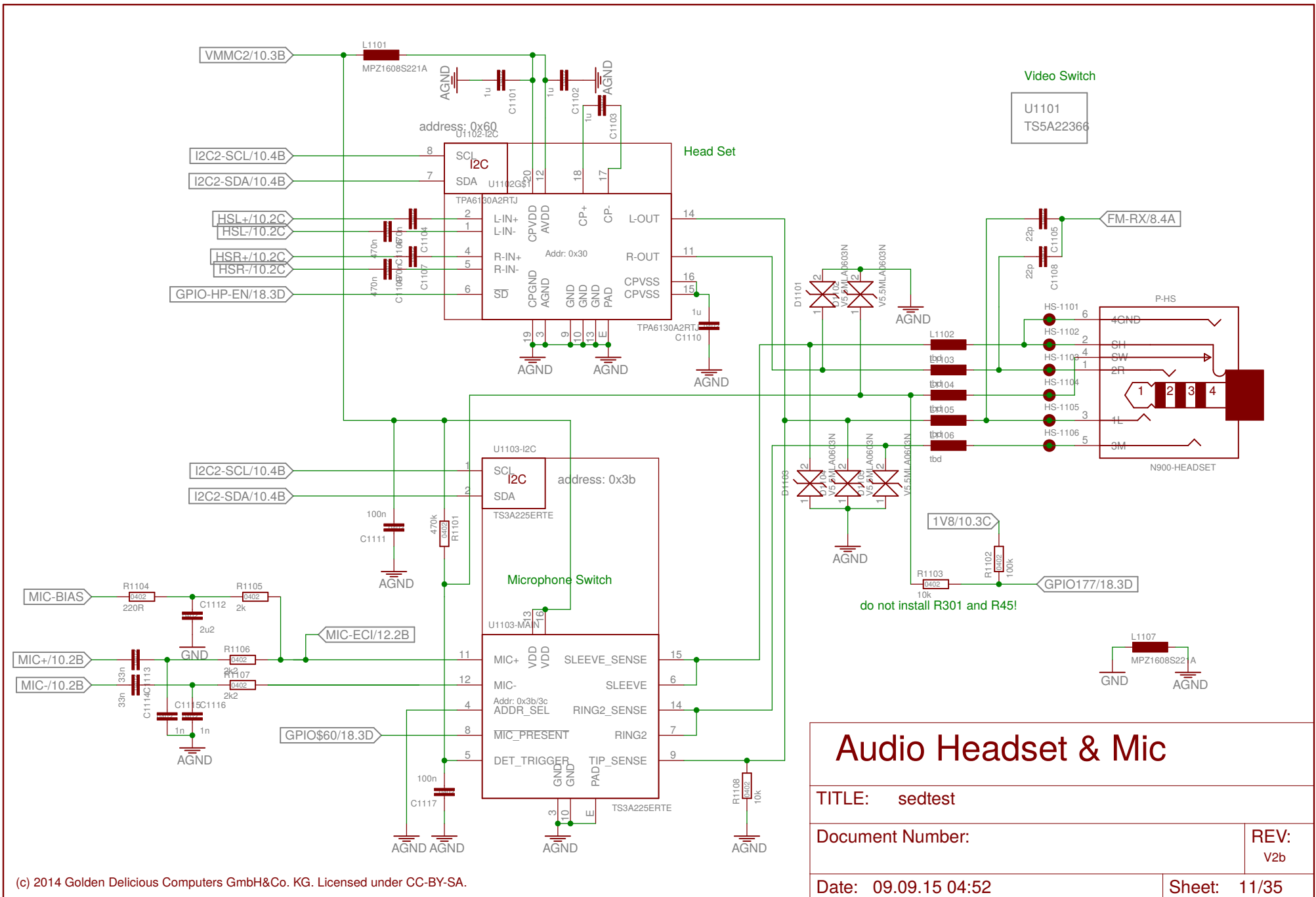

Audio Headset & Mic

TITLE: sedtest	
Document Number:	REV: V2b
Date: 09.09.15 04:52	Sheet: 11/35

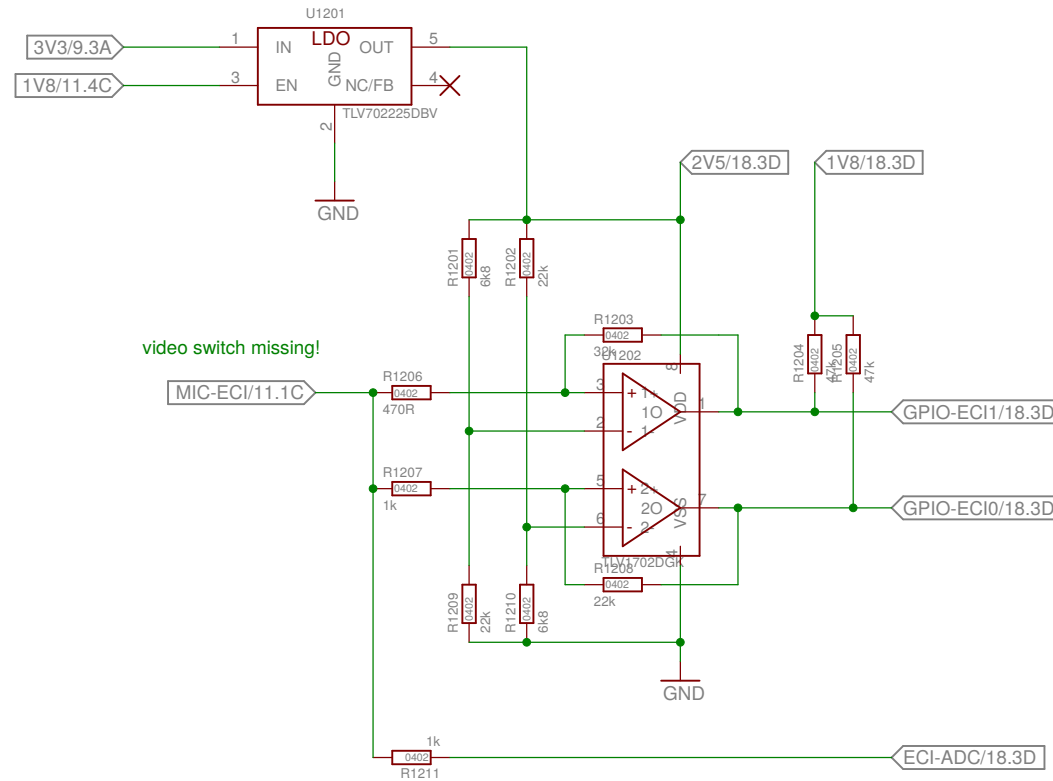

ECI

TITLE: sedtest

Document Number:

REV:
V2b

Date: 09.09.15 04:52

Sheet: 12/35

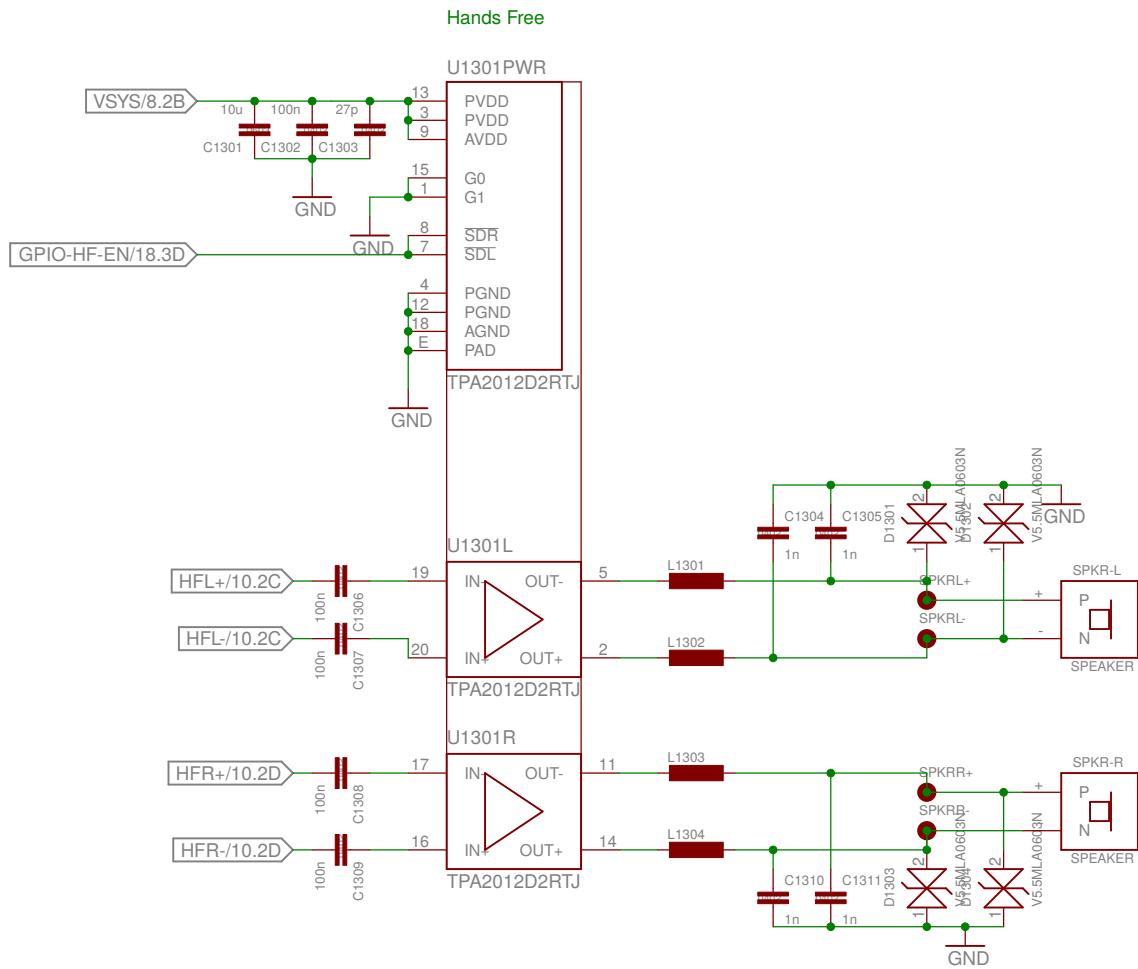

Audio Handsfree

TITLE: sedtest

Document Number:

REV:
V2b

Date: 09.09.15 04:52

Sheet: 13/35

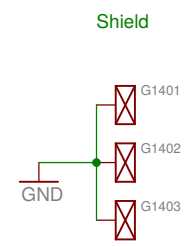
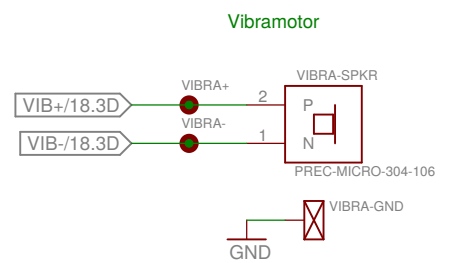
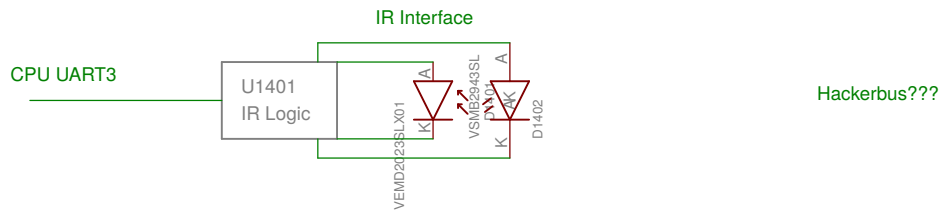
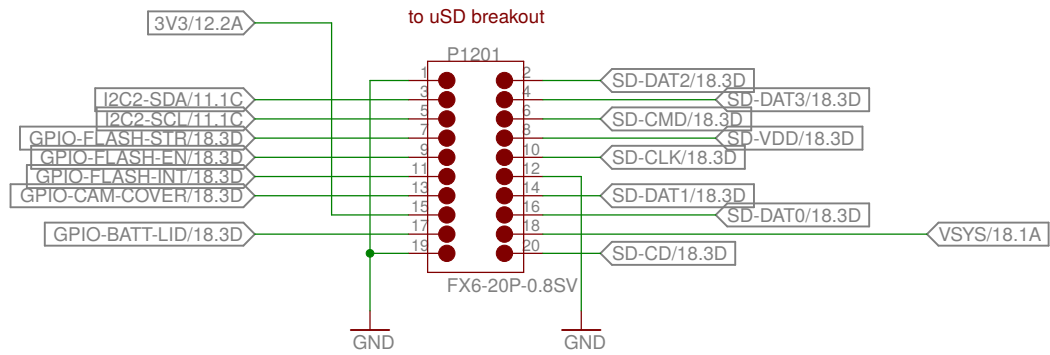

<h1>Misc (lower)</h1>	
TITLE: sedtest	
Document Number:	REV: V2b
Date: 09.09.15 04:52	Sheet: 14/35

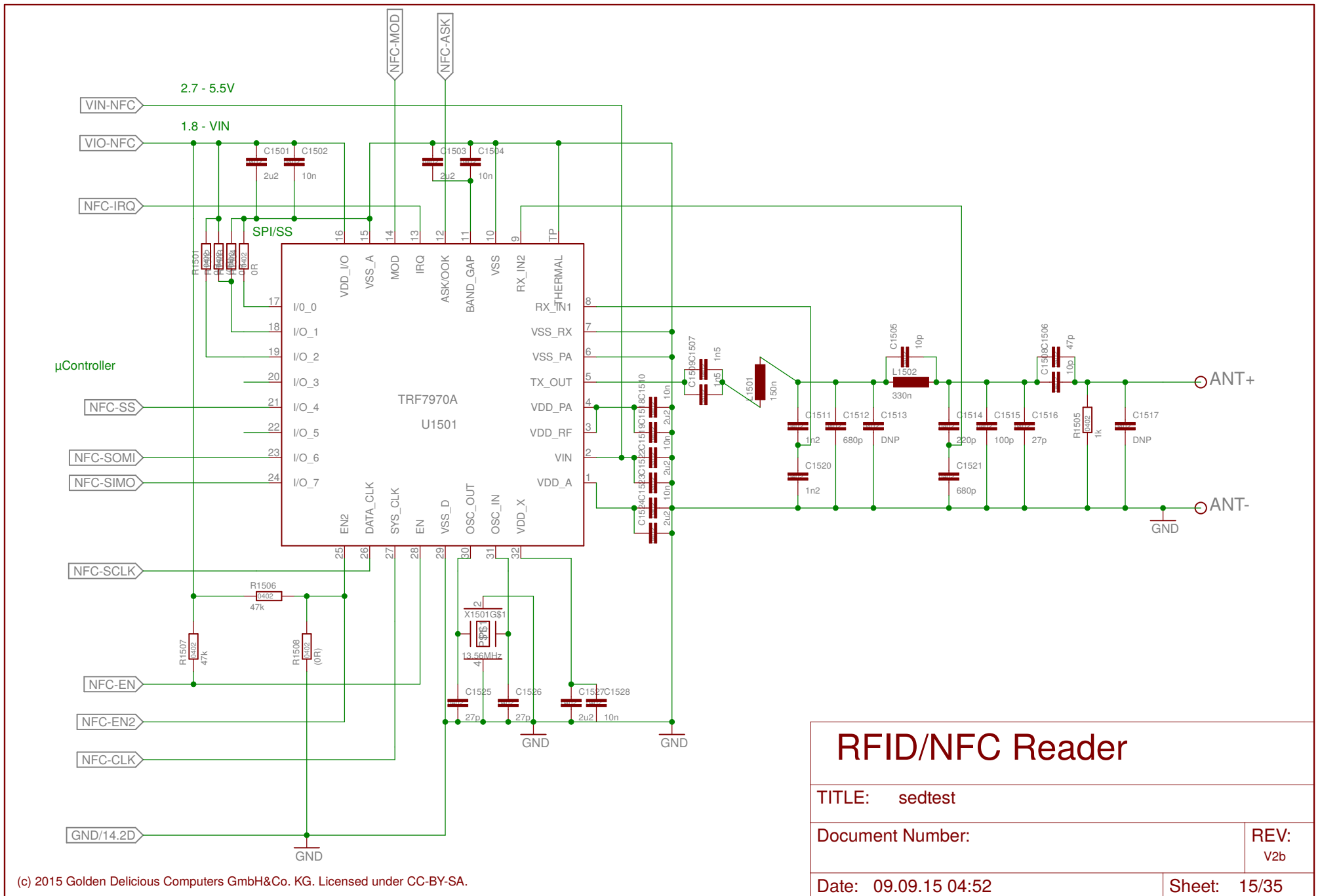

Hackerbus

TITLE: sedtest

Document Number:

REV:
V2b

Date: 09.09.15 04:52

Sheet: 16/35

Infrared

TITLE: sedtest

Document Number:

REV:
V2b

Date: 09.09.15 04:52

Sheet: 17/35

ca. 130 signals (to be counted exactly after definition of upper/lower split)

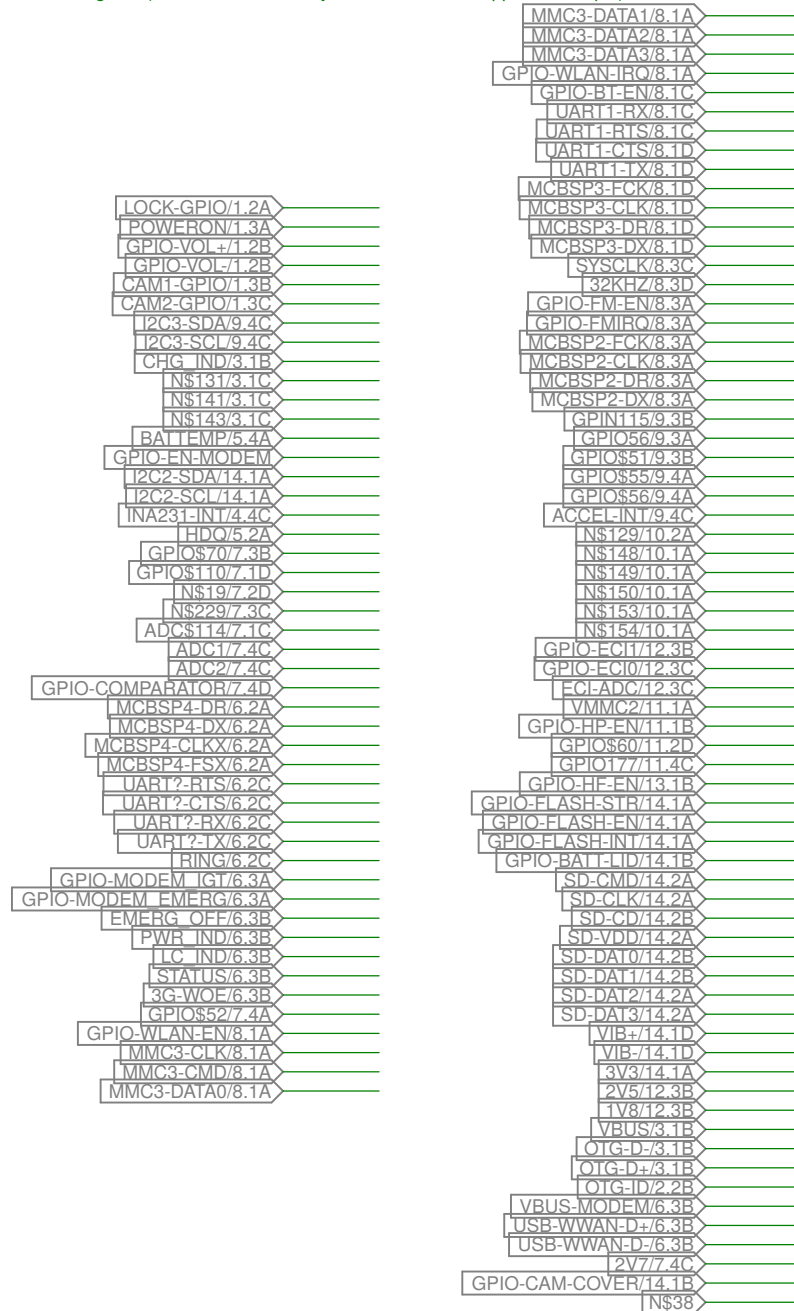

Pin assignment must be optimized for final component placement
we might have to switch to 80 or 100 pin connectors

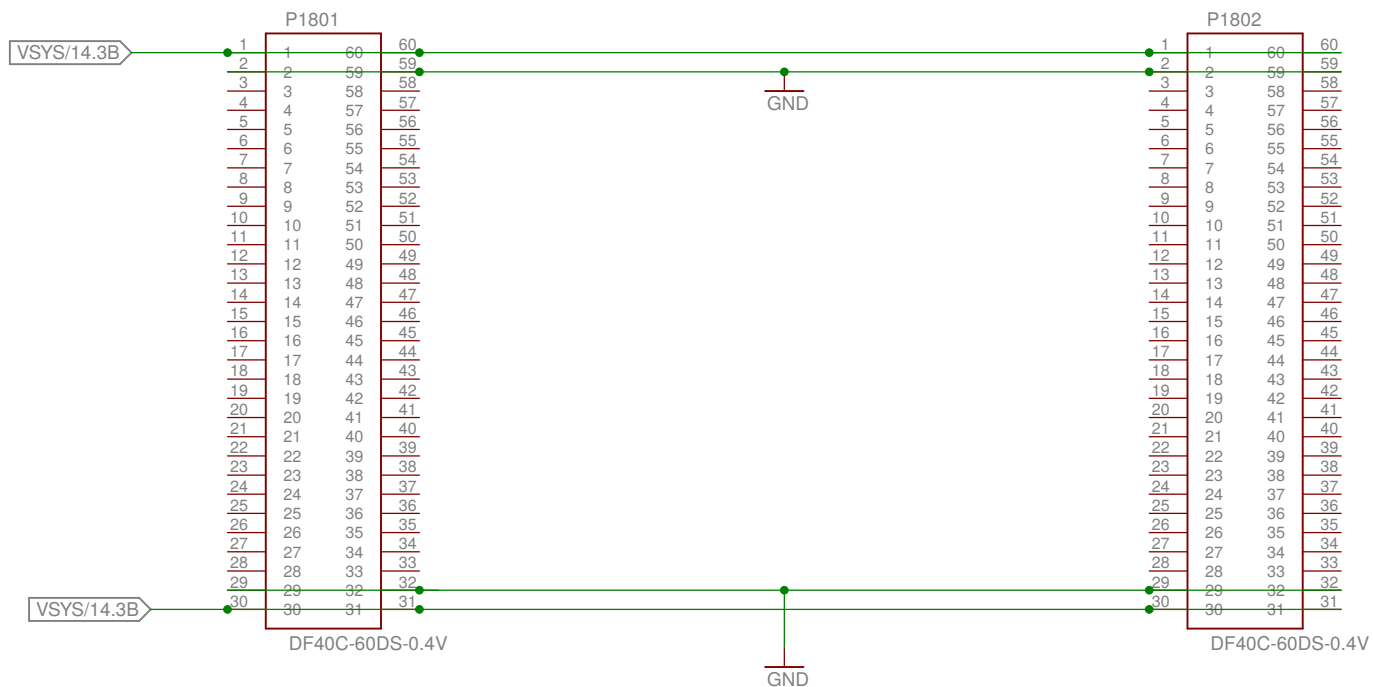

B2B to upper board

TITLE: sedtest

Document Number:

REV:
V2b

Date: 09.09.15 04:52

Sheet: 18/35

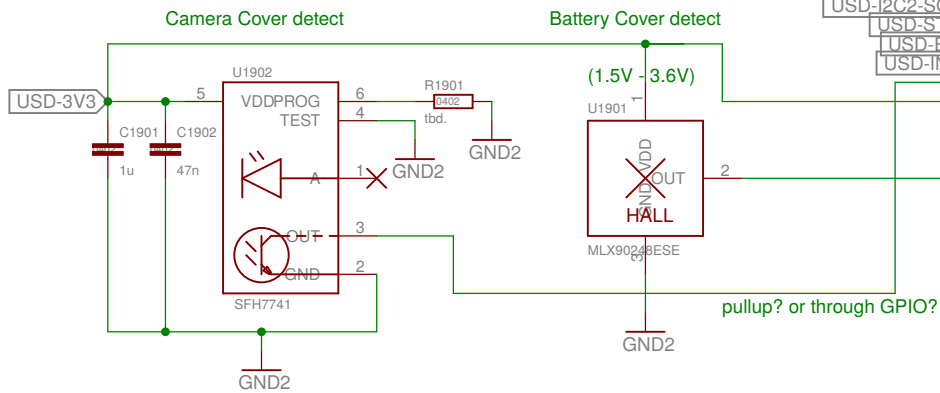

USD-I2C2-SDA
 USD-I2C2-SCL
 USD-STR
 USD-EN
 USD-INT

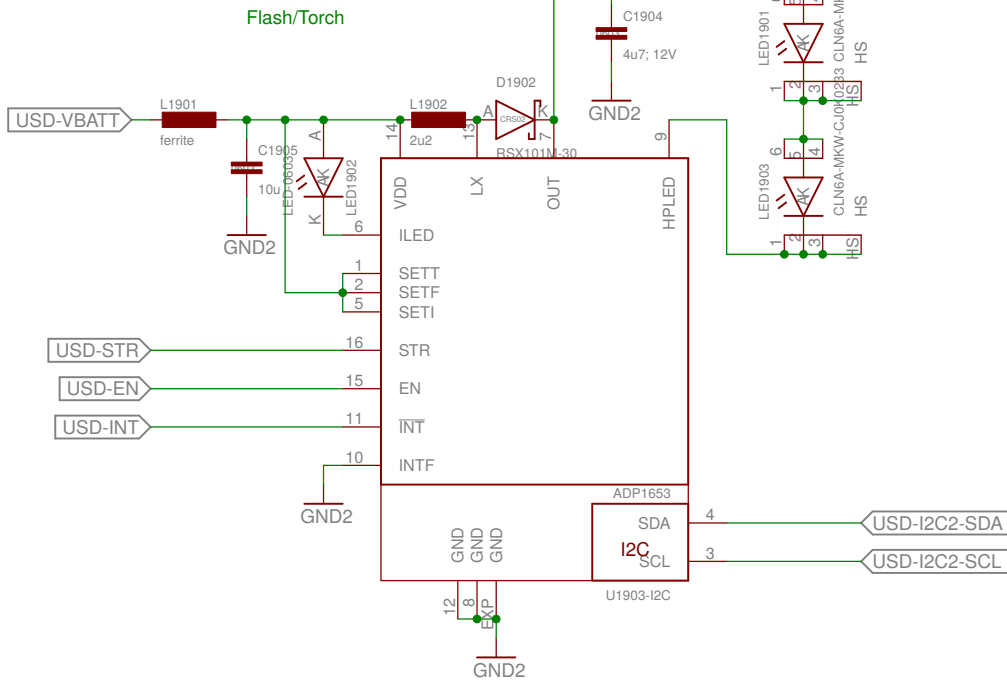
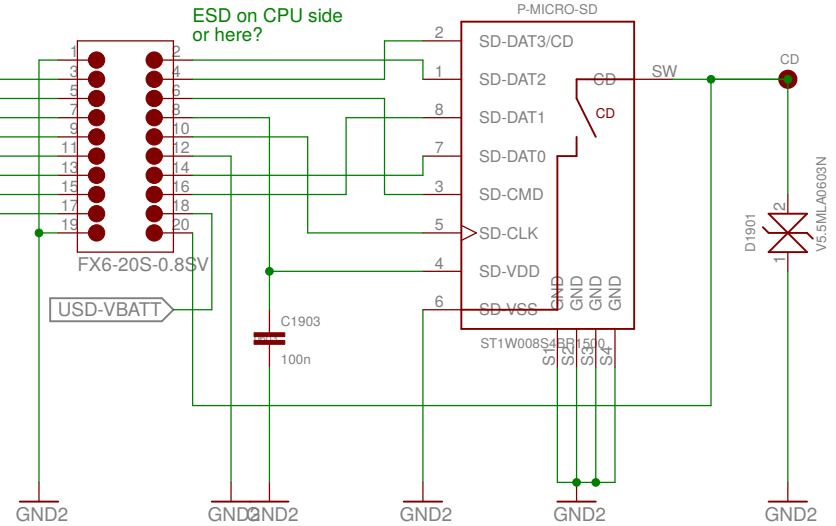

μSD Breakout Board

TITLE: sedtest

Document Number:

REV:
V2b

Date: 09.09.15 04:52

Sheet: 19/35

to be adjusted to lower board connector

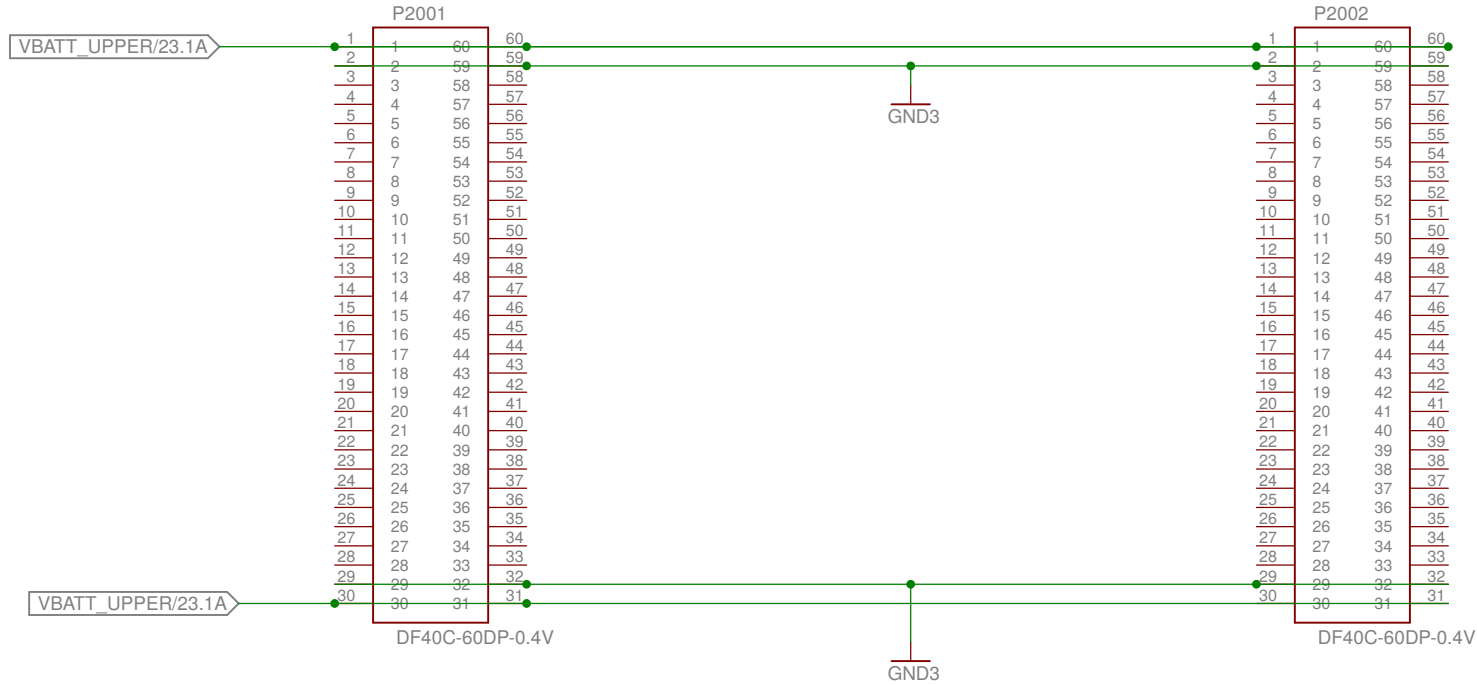

SHIELD

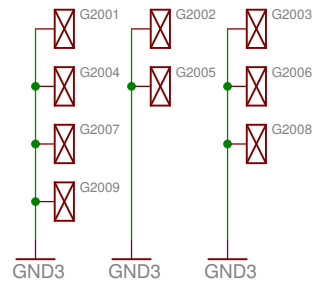

B2B to lower board

TITLE: sedtest

Document Number:

REV:
V2b

Date: 09.09.15 04:52

Sheet: 20/35

needs final tuning (which button on which position)
 VOL+ and VOL- could drive FETs sitting in the matrix

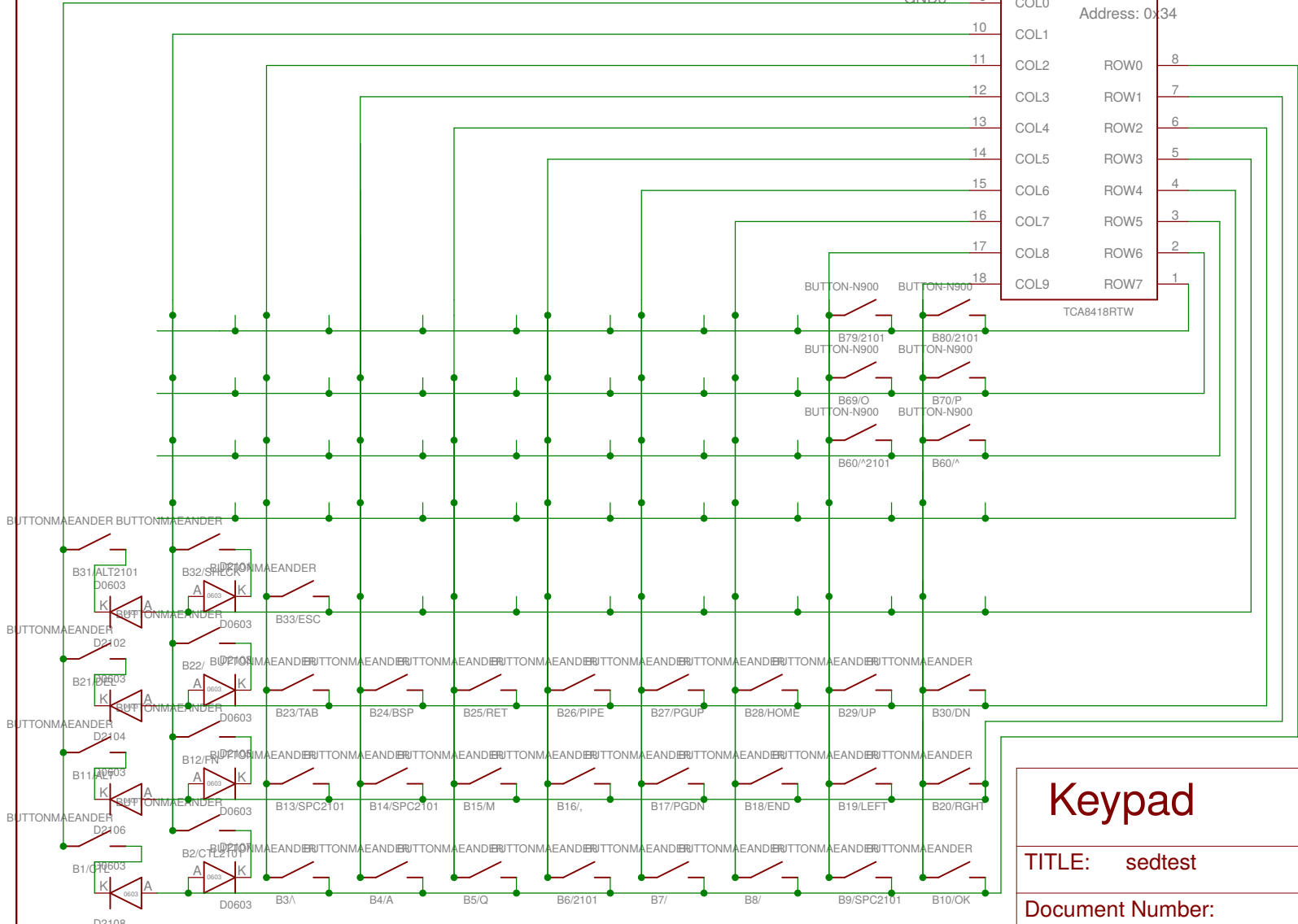
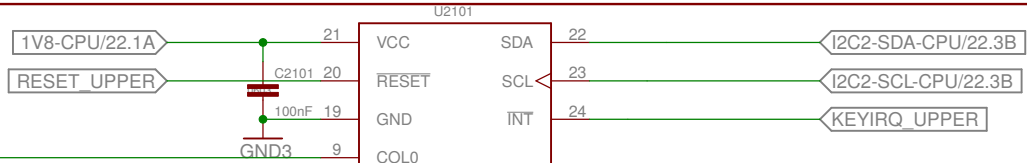

Keypad

TITLE: sedtest

Document Number:

REV:
V2b

Date: 09.09.15 04:52

Sheet: 21/35

replace by 2x RB521ZS8A30 for space constraints

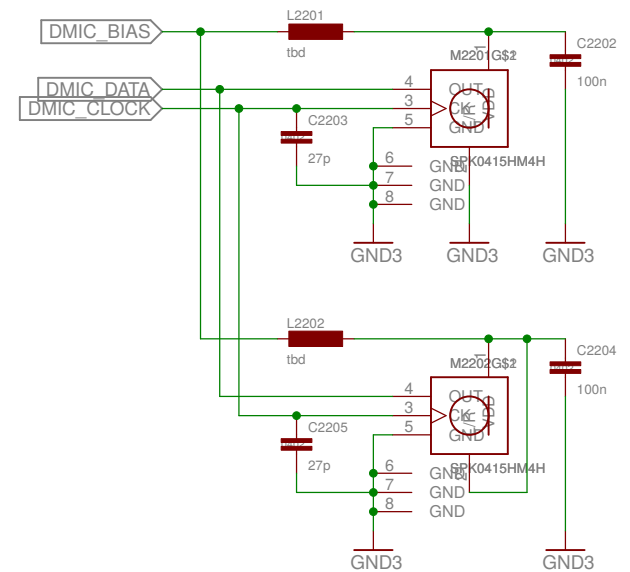
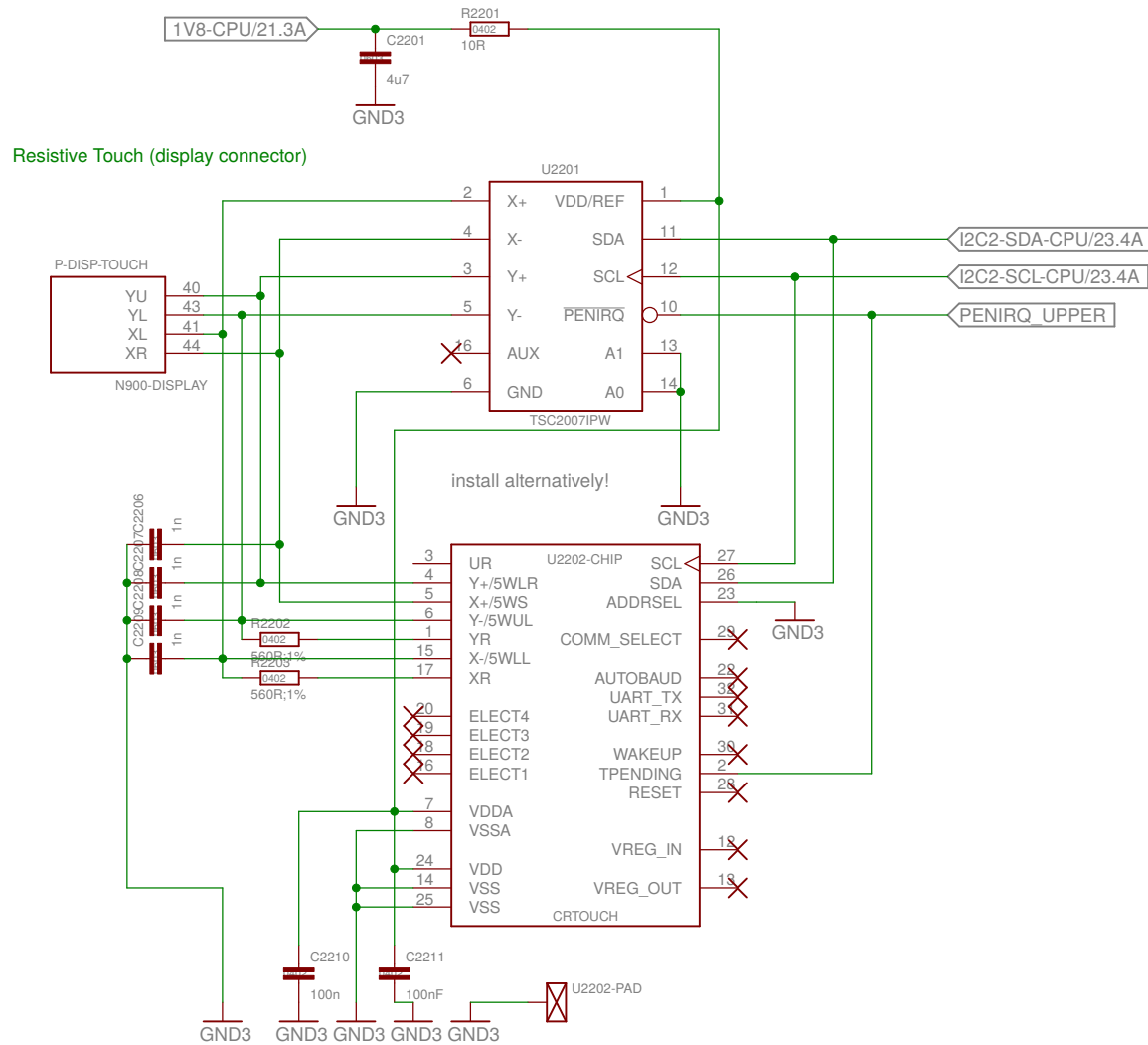

Display-Peripherals

TITLE: sedtest

Document Number:

REV:
V2b

Date: 09.09.15 04:52

Sheet: 22/35

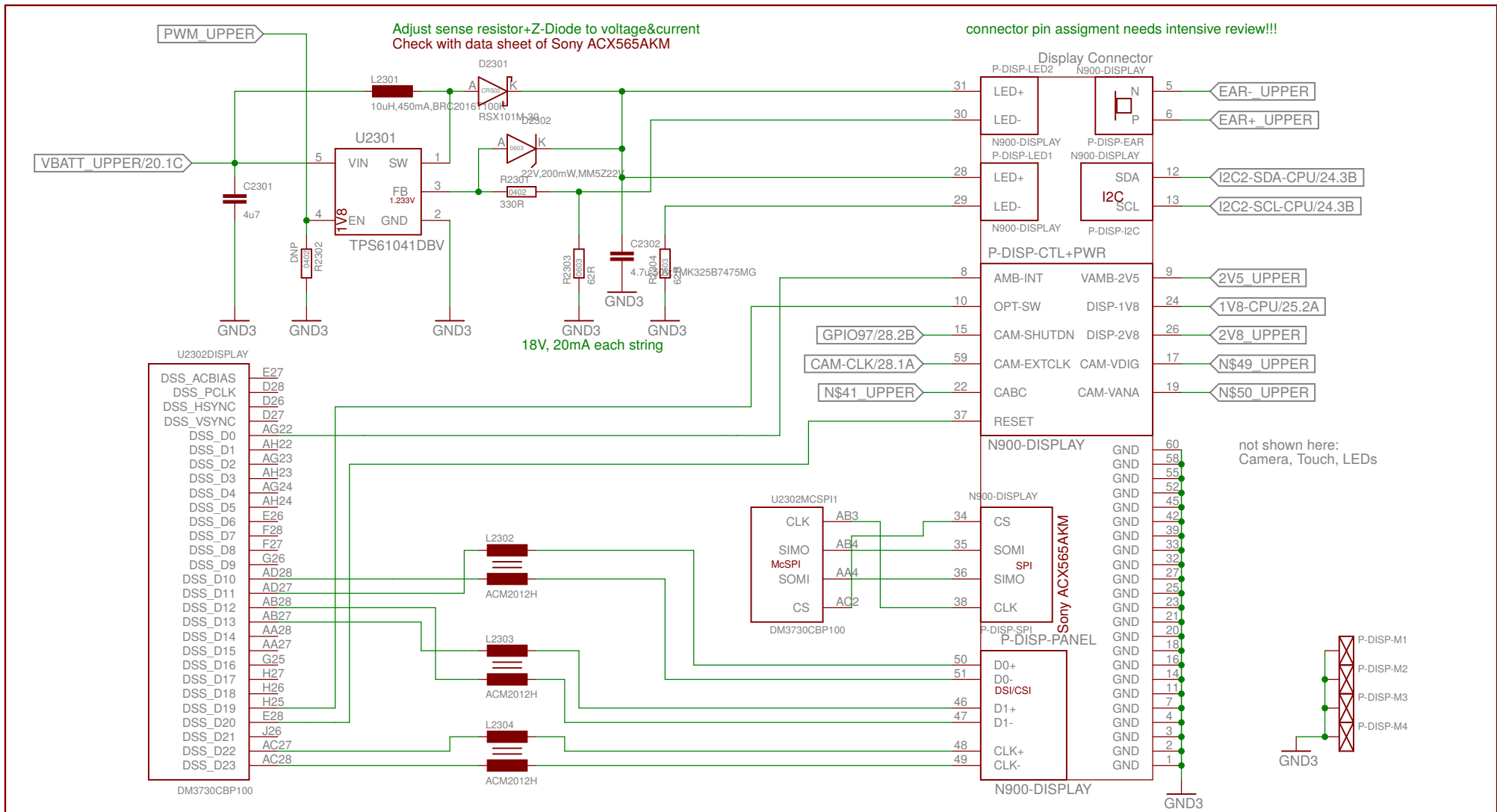

Display-Panel&Power

TITLE: sedtest

Document Number:

REV:
V2b

Date: 09.09.15 04:52

Sheet: 23/35

INCOMPLETE in V2

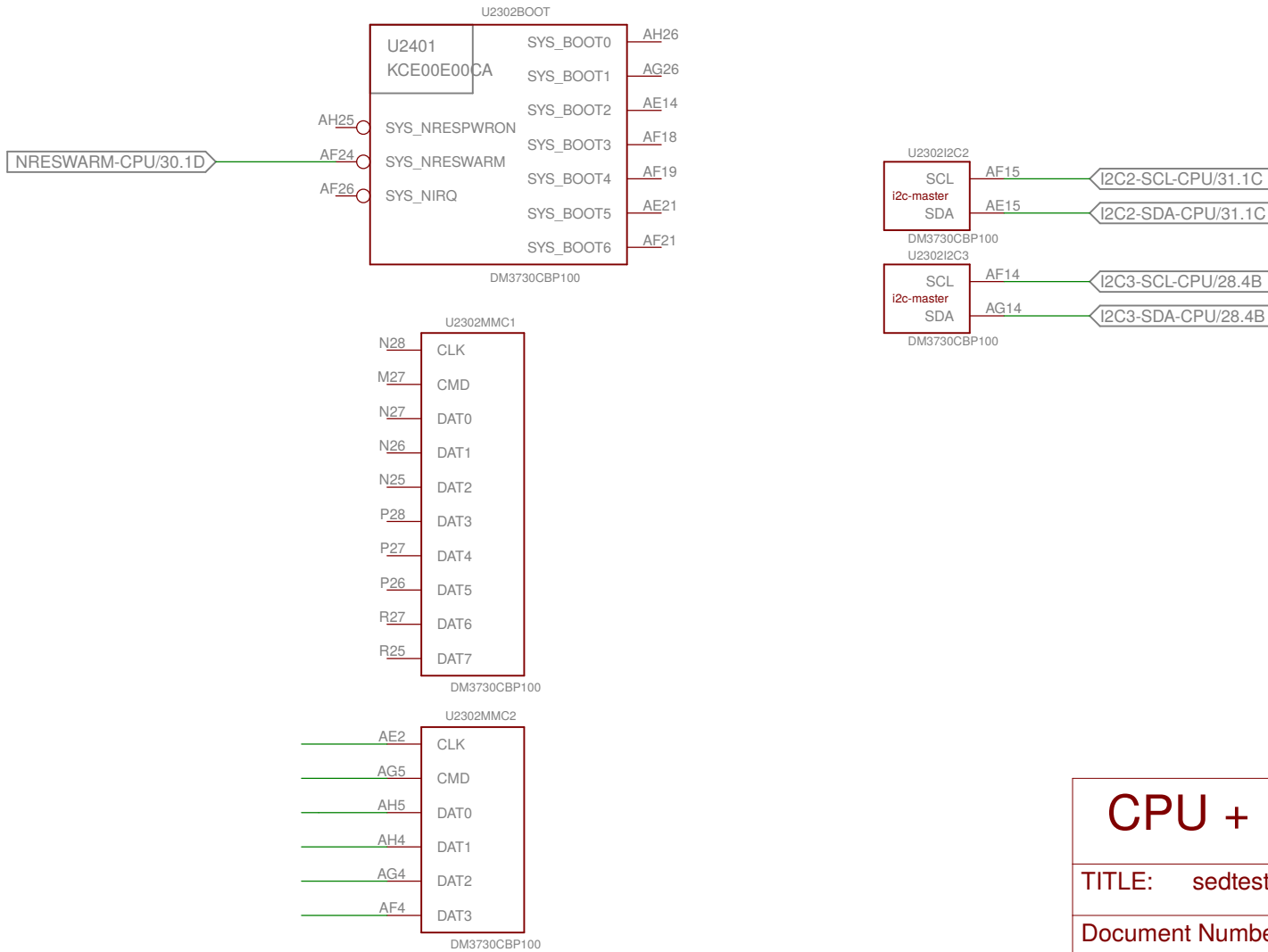

CPU + PoP RAM/NAND

TITLE: sedtest

Document Number:

REV:
V2b

Date: 09.09.15 04:52

Sheet: 24/35

INCOMPLETE in V2

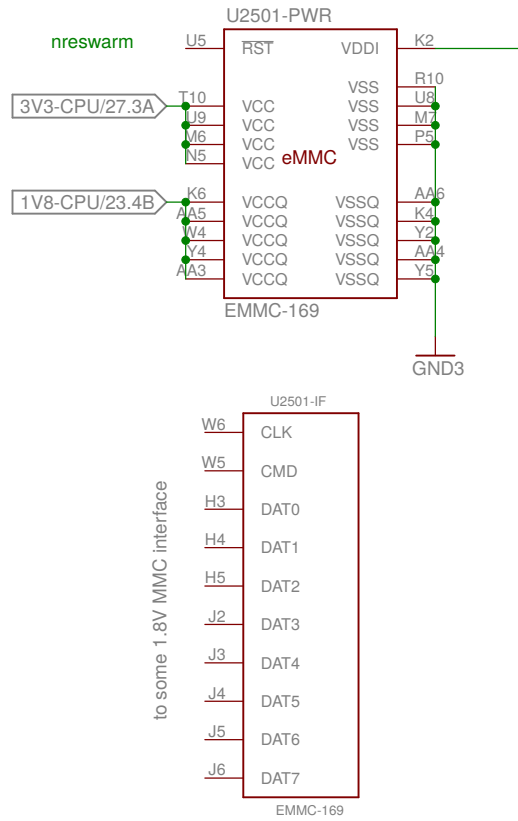

eMMC

TITLE: sedtest

Document Number:

REV:
V2b

Date: 09.09.15 04:52

Sheet: 25/35

INCOMPLETE in V2

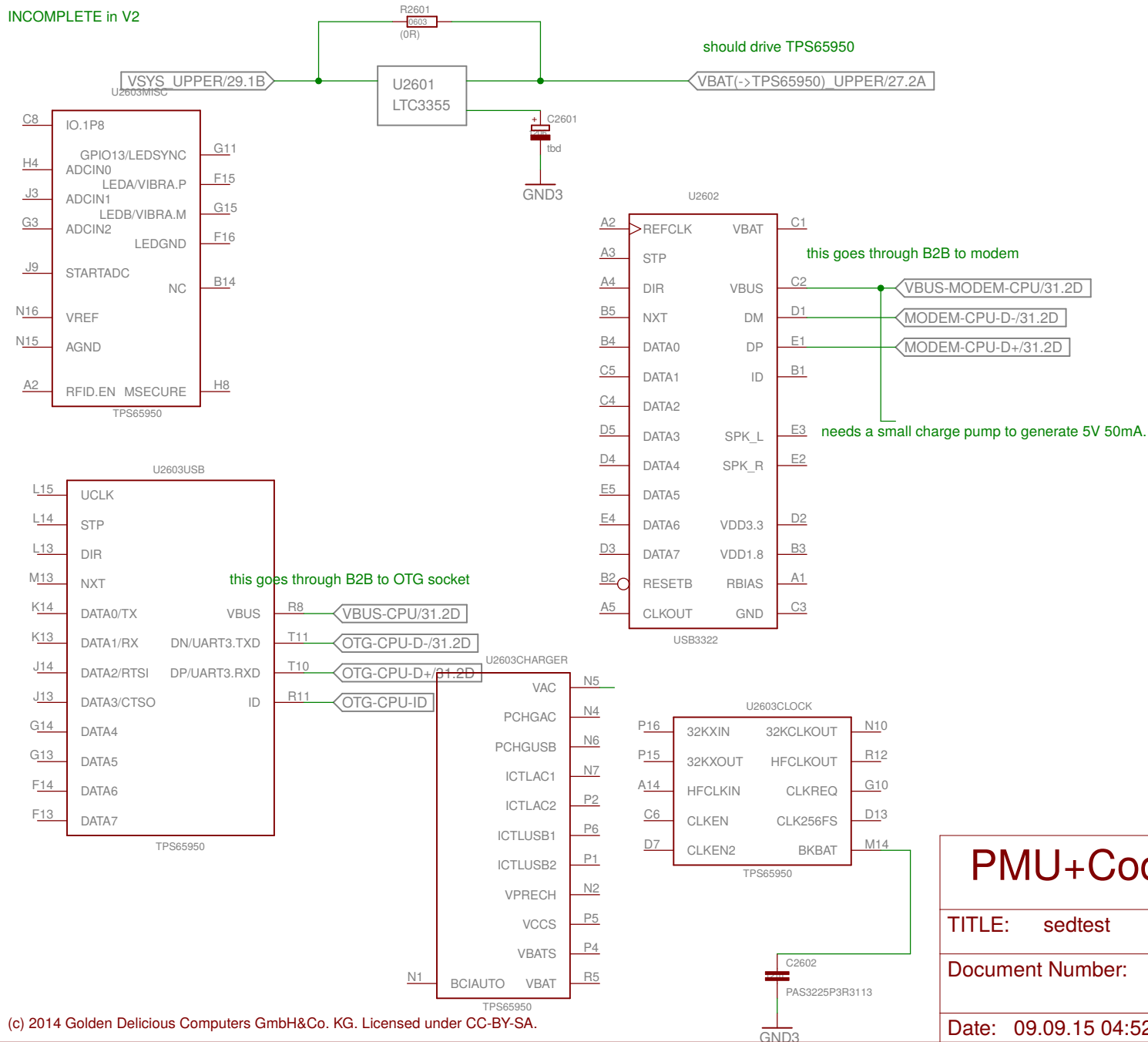

PMU+Codec

TITLE: sedtest

Document Number:

REV:
V2b

Date: 09.09.15 04:52

Sheet: 26/35

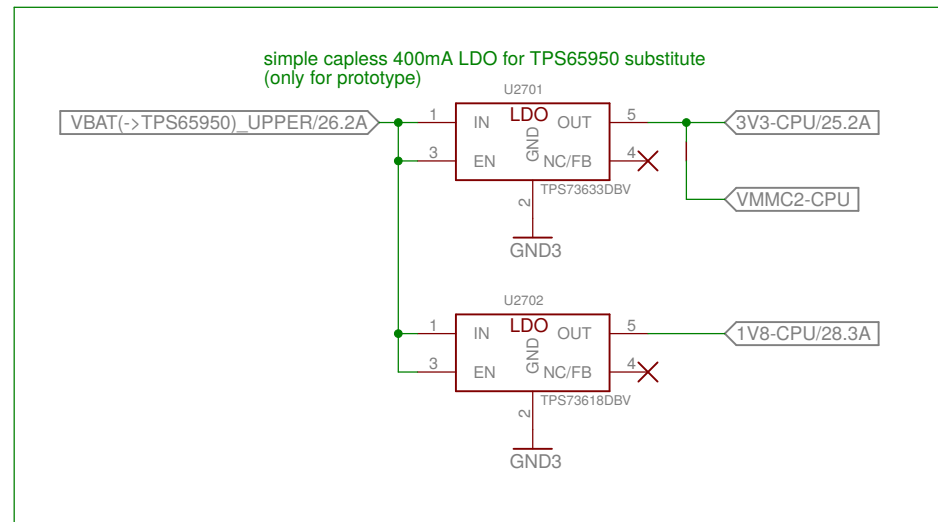

BB-XM Dummy (TWL4030)

TITLE: sedtest

Document Number:

REV:
V2b

Date: 09.09.15 04:52

Sheet: 27/35

INCOMPLETE in V2

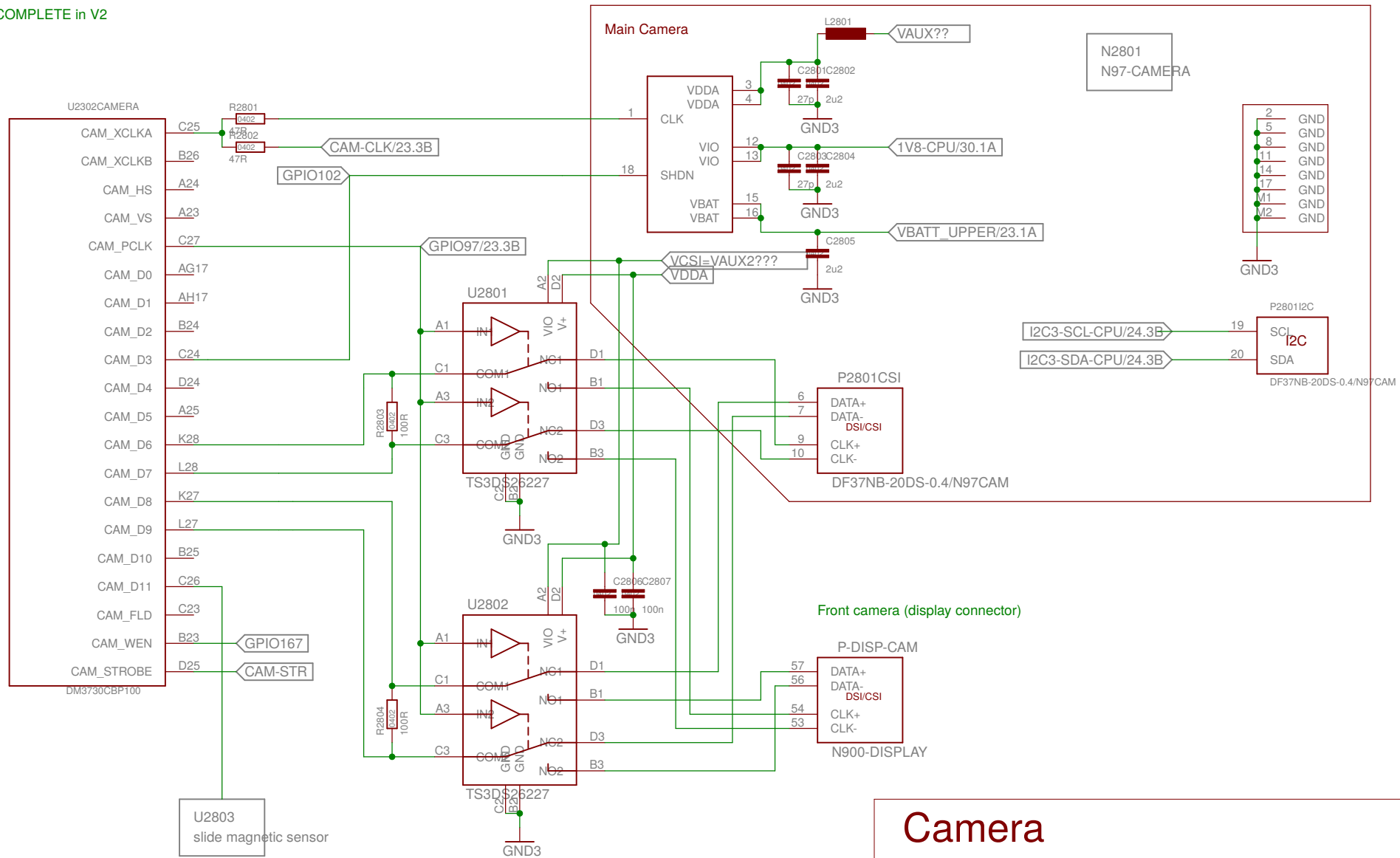

Camera

TITLE: sedtest

Document Number:

REV:
V2b

Date: 09.09.15 04:52

Sheet: 28/35

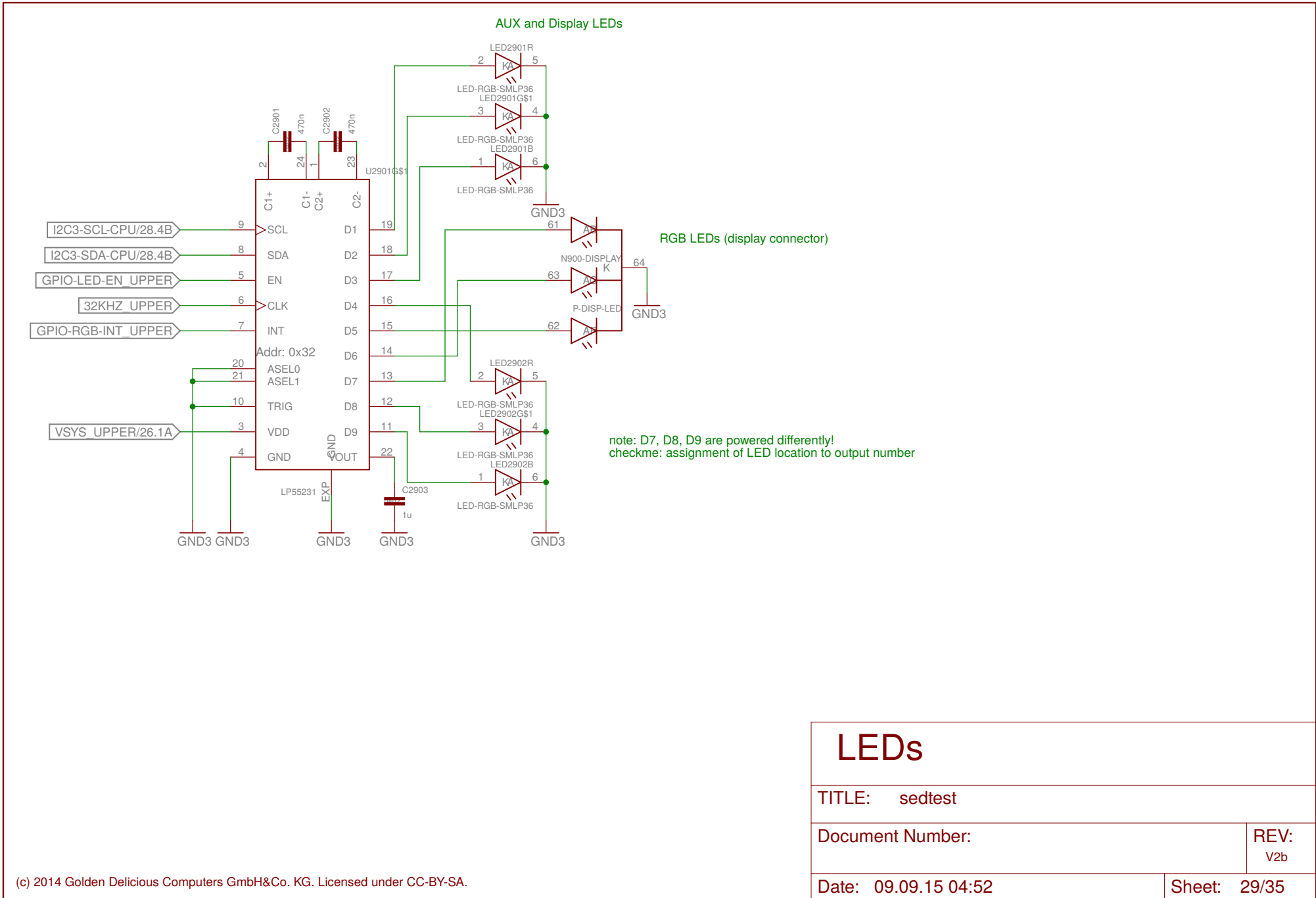

LEDs

TITLE: sedtest

Document Number:

REV:
V2b

Date: 09.09.15 04:52

Sheet: 29/35

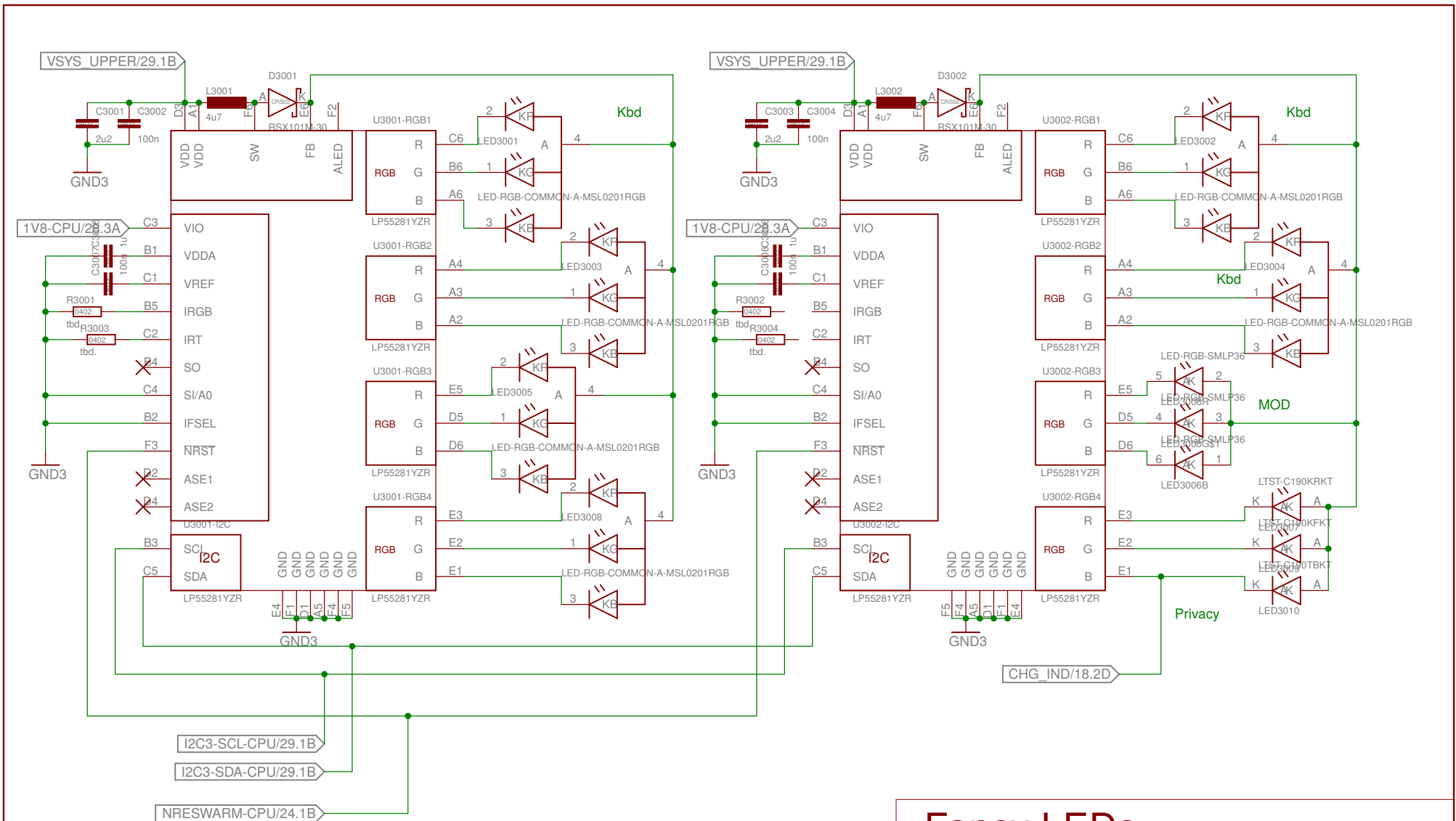

Fancy LEDs

TITLE: sedtest

Document Number:

REV:
V2b

Date: 09.09.15 04:52

Sheet: 30/35

These connectors allow to "emulate" the DM3730 by connecting a BB-XM

INCOMPLETE
prototype only

connect to respective CPU-pads

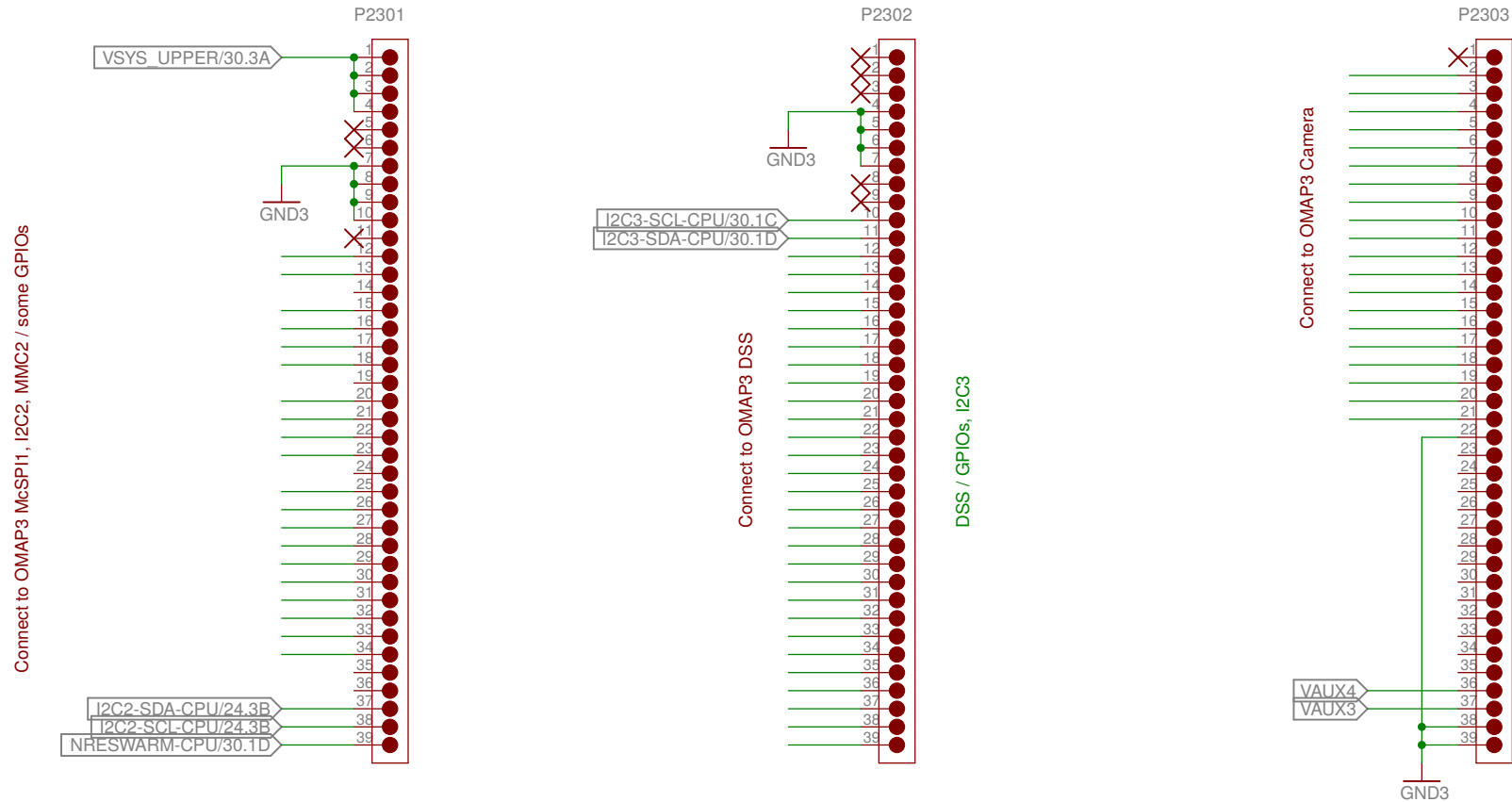

connect to BB
by some Micro-USB cable

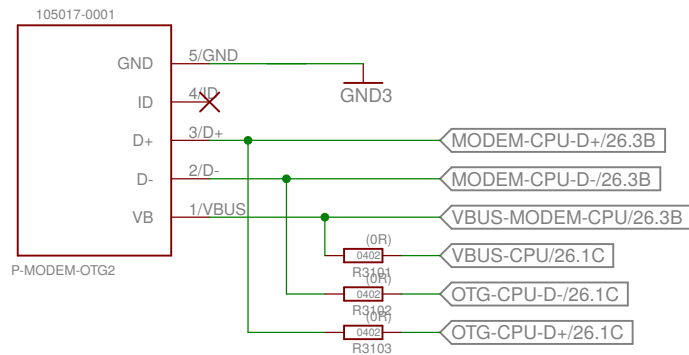

Connector to BB

TITLE: sedtest

Document Number:

REV:
V2b

Date: 09.09.15 04:52

Sheet: 31/35

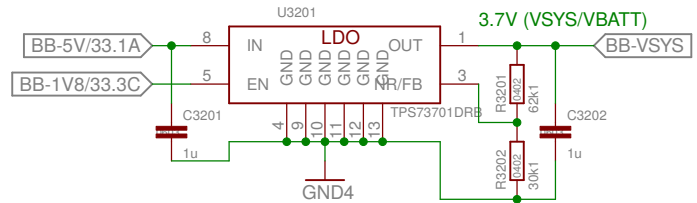

Ersetzen durch 2A buck converter

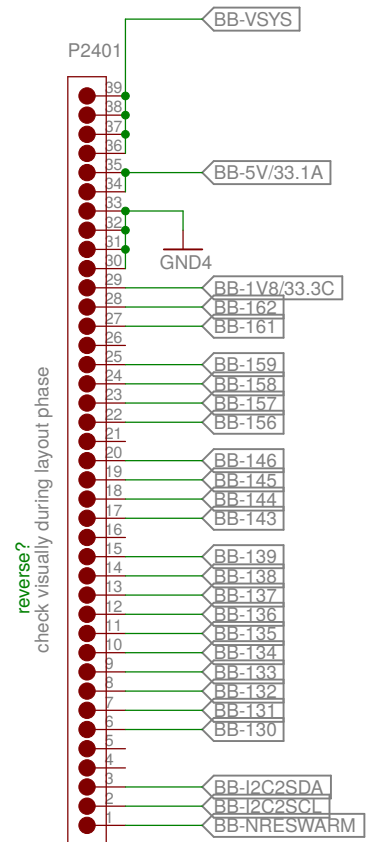

reverse?
check visually during layout phase

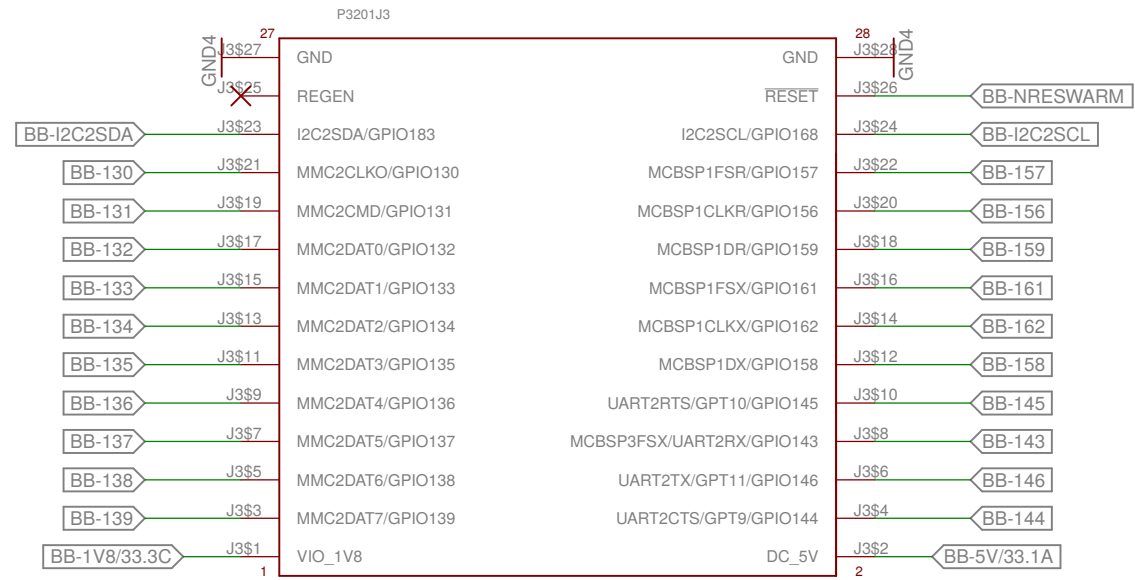

Top View on BB

BB-XM Adapter (CPU)

TITLE: sedtest

Document Number:

REV:
V2b

Date: 09.09.15 04:52

Sheet: 32/35

reverse?
check visually during layout phase

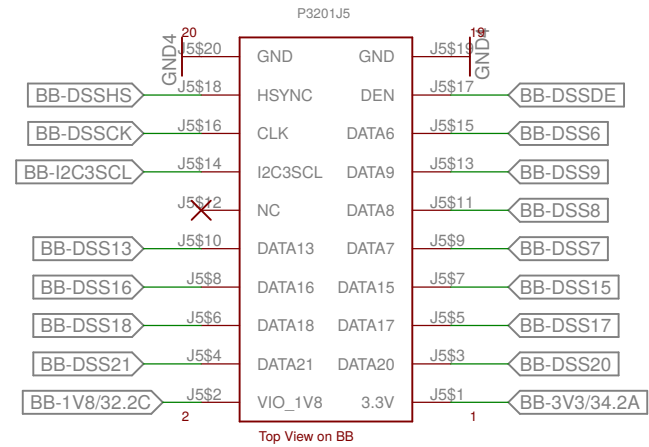
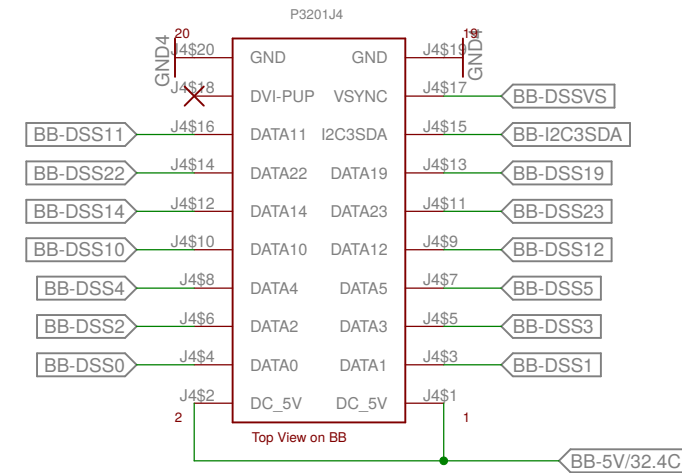
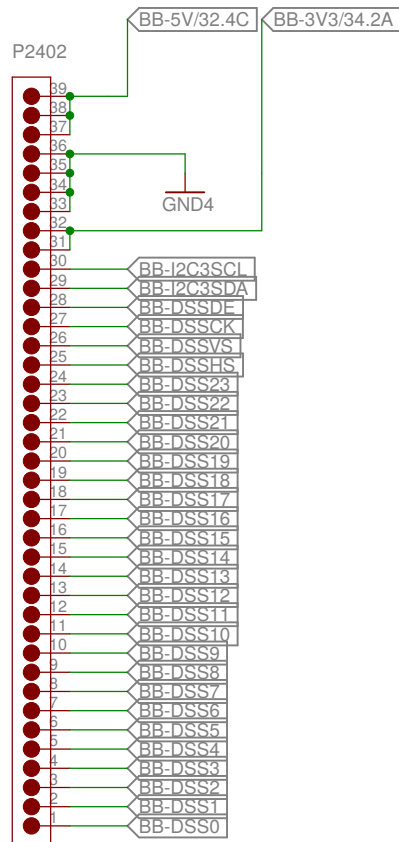

BB-XM Adapter (DISP)

TITLE: sedtest

Document Number:

REV:
V2b

Date: 09.09.15 04:52

Sheet: 33/35

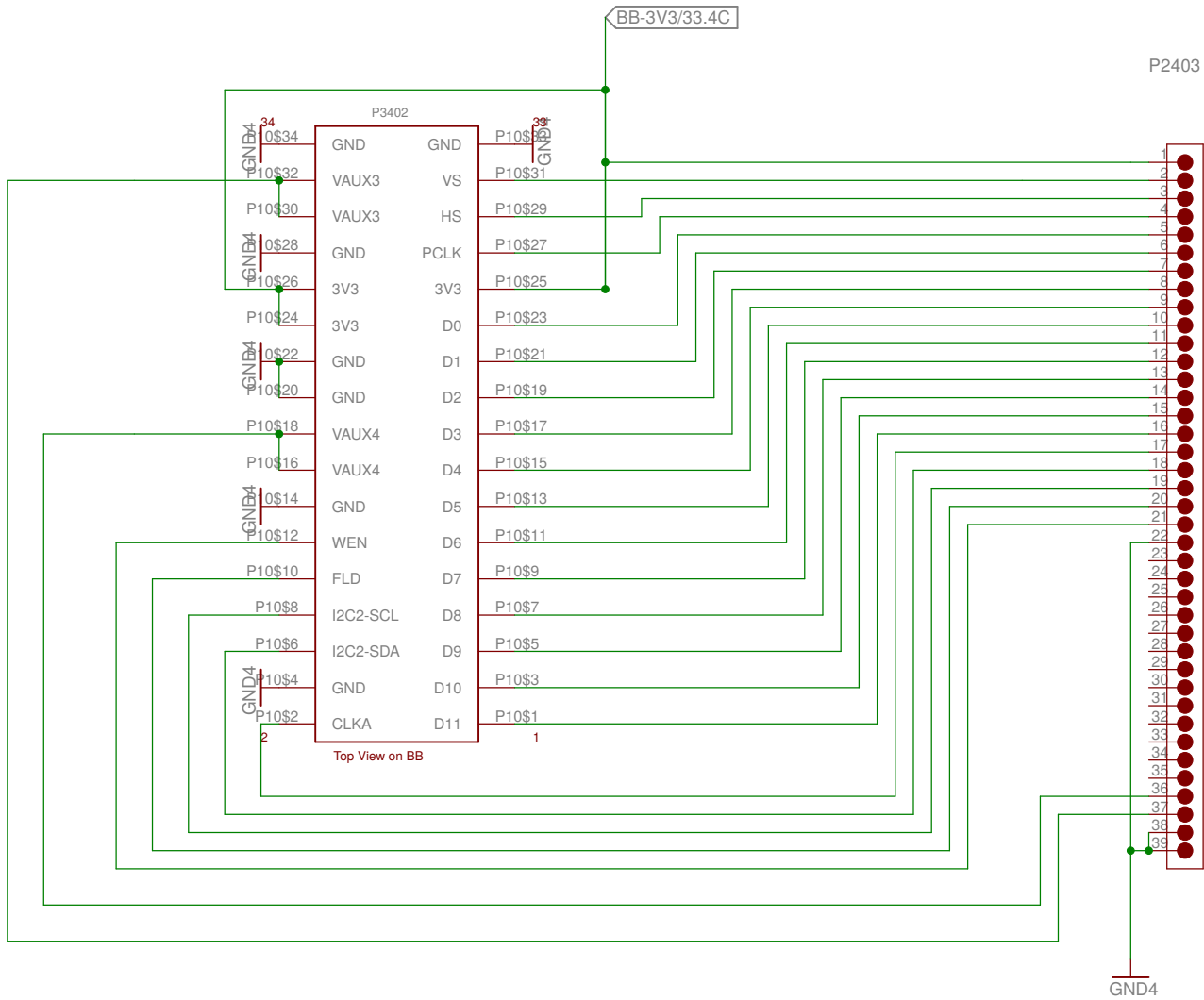

BB-XM Adapter (CAM)

TITLE: sedtest

Document Number:

REV:
V2b

Date: 09.09.15 04:52

Sheet: 34/35

Molex Jumper cables to connect BB-XM-Adapter to Uppwer board

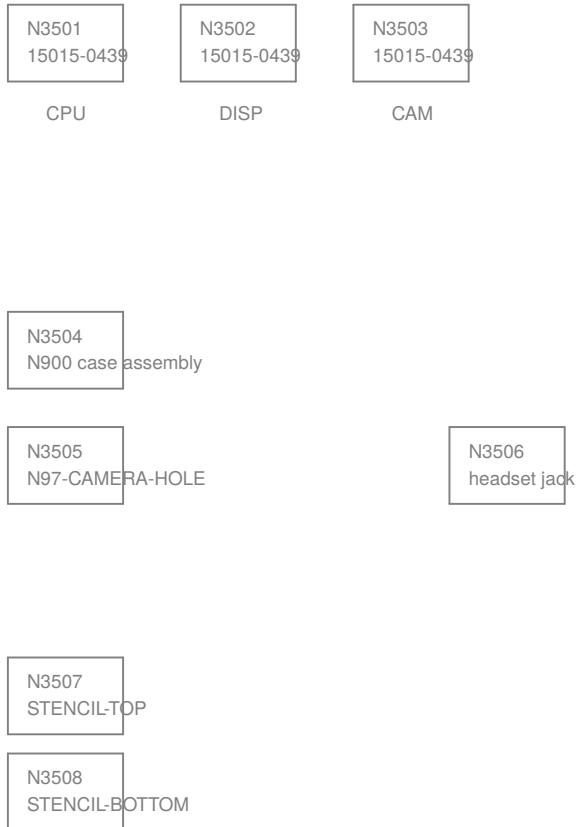

No-Solder Components

TITLE: sedtest

Document Number:

REV:
V2b

Date: 09.09.15 04:52

Sheet: 35/35